



CHAMBERSBURG MODEL "L" POWER/DROP



FIG. 1

**...proven performance with
new design features to satisfy
today's forging demands.**

HIGHLIGHTS OF THE MODEL "L" POWER/DROP INCLUDE:

The Chambersburg Model "L" POWER/DROP represents the most advanced air or steam operated, double-acting hammer available to the impression die forging industry.

It incorporates new features suggested by users of power hammers to achieve efficiency and productivity so as to produce forgings to close limits of tolerance at the lowest cost per piece.

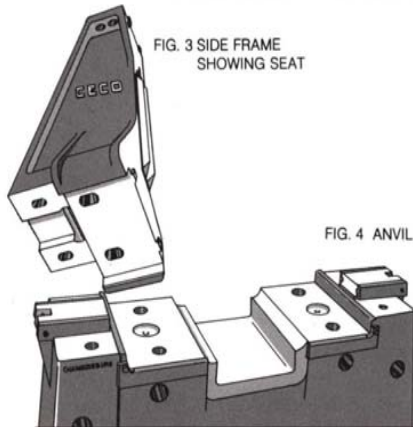
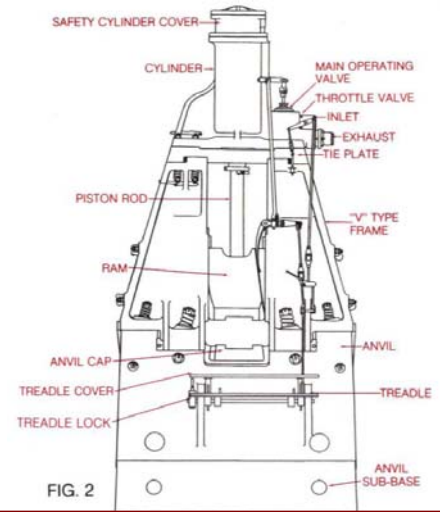

INDIVIDUAL DESIGN

Each size Model "L" POWER/DROP is designed from die line to most efficiently accomplish the job for which it is intended. The massive cast steel anvil (Fig. 4) converts the greatest amount of available energy into useful work. On rated sizes up to 10,000 lbs., the anvil is one piece with a ratio of 20:1 with respect to falling weight. On hammers 12,000 lb. and larger, multiple anvil sections are used and the weight ratio is increased to 25:1 to maintain efficiency. Anvil sections are tongued and grooved to each other and secured with heavy dowels.

Only Chambersburg POWER/DROPS have large frame seats together with outside thrust shoulders to provide maximum resistance to frame twist and to preserve die alignment (Fig. 3). Tapered, forged steel wearing plates between the frames and anvil provide small increments of upperworks adjustment to correct die alignment. Other vertical bearing surfaces are provided with renewable steel wearing plates.

FRAME DESIGN

Model "L" POWER/DROPS utilize "V" type design solid, cast steel frames. The "V" section frame was selected for its greater strength and rigidity than box section or I-beam section frames. Front-to-back ram guide proportions are increased to permit closer guidance of the ram and minimize side twist. A 4-"V" guide construction (Fig. 6) is standard on all sizes. Guide shoes are forged steel and straight tapered.

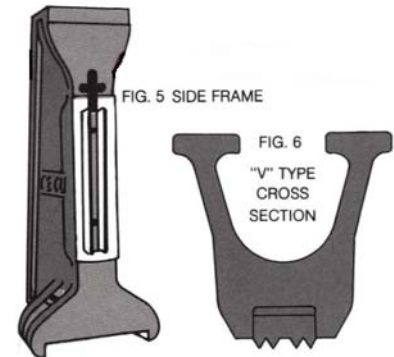

TIE PLATE and CYLINDER

The frame tops and cylinder are secured by a heavy forged steel tie plate. Stepped joints provide greatest resistance to twisting with renewable shim packs to provide correct vertical frame alignment.

The newly designed cylinder with strengthened support web is cushioned by Fabreka pads between the tie plate and cylinder to protect the vital valve parts.

The main cylinder bore (on sizes up to 20,000 lbs.) as well as the bores of the main and throttle valve are equipped with long life stainless steel liners. The cylinder is self-draining and the cylinder bottom is cast solid except for the rod opening, eliminating joints which cause leakage and breakage of studs. A new, three-piece piston gland gives floating action to reduce wear and is provided with "V" square type packing to ease packing adjustments.

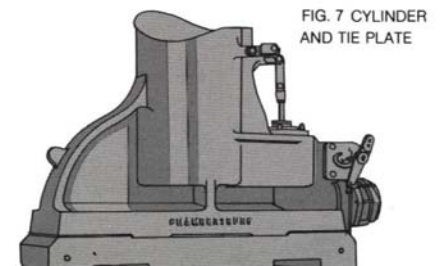
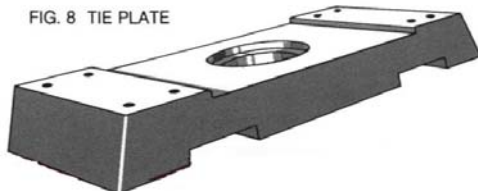

POWER ECONOMY

The Model "L" POWER/DROP retains the operating advantages of differential cylinder porting. In this novel system, the exhaust port is designed to permit a more rapid exhaust, and a rapid and short filling period near the point of die closure and the intake port permits a long expansion of top air or steam on the down stroke. High impact velocities and quick return of the ram result with prudent use of power.

FIG. 9 EXHAUST PORT STRIKING POSITION

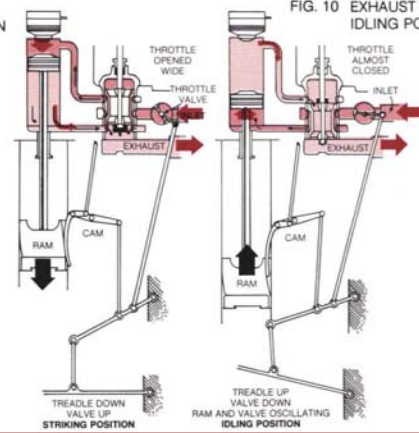

EASE OF OPERATION

Chambersburg Model "L" POWER/DROPS, 4000 lb. and larger, are equipped with Power/Trol, a hydra-mechanical servo type control system which eliminates most of the fatigue and physical effort associated with large hammer operation yet retains full blow control sensitivity.

Rigging is provided with self-aligning, replaceable antifriction bushings to reduce friction and improve control.

FIG. 11 POWER/TROL
Photo courtesy of Wyman-Gordon Co.

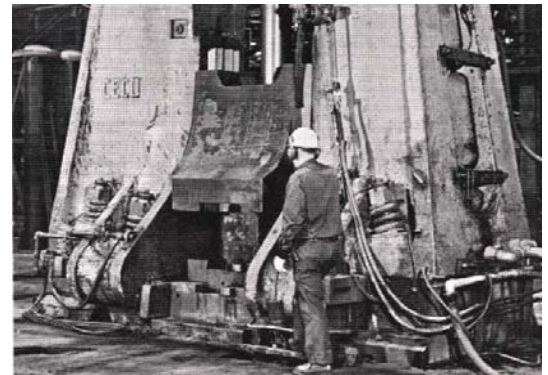

AUTOMATIC LUBRICATION

Provided for the ram guides and the main cylinder's ports and bores by a motor-driven lubricator. Because the lubricator is controlled by application of power to the hammer, lubricant is delivered to these critical areas only when the hammer is operating, or idling under power.

Chambersburg Model "L" POWER/DROPS are equipped with a number of safety features which include:

1. Safety cables attach vulnerable overhead assemblies to the hammer structure.
2. The Safety Cylinder Cover provides positive protection against piston overtravel.
3. The Chambersburg Safety Valve, a stop arranged under the main operating valve, shuts off air or steam in the event of damage to the valve gear.
4. A ram safety mark on the left hand frame indicates the lowest point of ram stroke position.
5. Treadle Lock and Cover. Consists of a safety board that protects the treadle from falling objects and inadvertent actuation, and a positive treadle locking device that allows the treadle to be manually and positively locked in the raised position.
6. A Wedge-Type Ram Safety Rest inserted into a machined slot in the left hand guide to support the ram, when it is necessary to block the ram in the raised position.

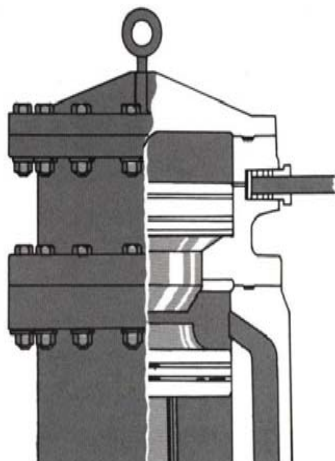

FIG. 12 SAFETY CYLINDER COVER

SAFETY FEATURES



FIG. 13 SAFETY TREADLE AND COVER

OPTIONAL KORFUND HEAVY-DUTY SHOCK INSULATION PADS

A system that greatly reduces impact vibrations transmitted to the ground in the area surrounding the hammer.

CHANGES IN SPECIFICATIONS

The builder reserves the right to make substitutions in the design and material specifications consistent with good engineering practices and the stated performance standards.

GENERAL SIZES MODEL "L" POWER/DROP

inches and pounds shown in white bands, metric measurements shown in color bands

Rated Size	Nominal Bore*	Inlet	Exhaust	Ram Stroke	Between Guides	Ram F to B	Anvil Cap F to B	Min. Die Bearing Area	Min. Die Striking Area ¹	Floor Space	Overall Hgt. Above Floor
Lbs.	Ins.	Ins.	Ins.	Ins.	Ins.	Ins.	Ins.	Sq. In.	Sq. In.	Ins.	Ft.-Ins.
Kg.	mm.	mm.	mm.	mm.	mm.	mm.	mm.	Sq. cm	Sq. cm	mm	mm
1000	7-1/2	3	3-1/2	42	16	16	20	130	35	75-1/2 x 35	15 - 3-1/2
454	191	76	89	1067	406	406	508	838.7	225.8	1918 x 889	4661
1500	9	3	3-1/2	44	18	19	23	170	43	82 x 39	15 - 10-1/2
680	229	76	89	1118	457	483	584	1096.8	277.4	2083 x 991	4839
2000	10-1/4	3	3-1/2	46	20	21	26	210	53	88-1/2 x 43	16 - 10-1/2
907	260	76	89	1168	508	533	660	1354.9	341.9	2248 x 1092	5144
2500	11	3	3-1/2	47	21	22	27	230	58	94 x 47-1/2	17 - 1
1134	279	76	89	1194	533	559	686	1483.9	374.2	2388 x 1207	5207
3000	12	3-1/2	5	48	23	25	30	290	72	101-1/2 x 52	17 - 7
1361	305	89	127	1219	584	635	762	1871.1	464.5	2578 x 1321	5359
4000	14	3-1/2	5	49	25	27	32	405	97	112 x 59	18 - 2
1814	356	89	127	1245	635	686	813	2613.1	625.8	2845 x 1499	5537
5000	15-1/2	4	6	50	27	29	36	470	113	121 x 64	19 - 0
2268	394	102	152	1270	686	737	914	3032.4	729.0	3073 x 1626	5791
6000	17	4	6	51	28	31	36	520	125	129-1/2 x 68	19.3
2722	432	102	152	1295	711	787	914	3355.0	806.5	3289 x 1727	5867
8000	19	5	8	52	29	35	40	610	145	137 x 77	20 - 0
3629	483	127	203	1321	737	889	1016	3935.7	935.5	3480 x 1956	6096
10000	21	5	8	52	30	38	44	800	188	145 x 78	20 - 6
4536	533	127	203	1321	762	965	1118	5161.6	1212.9	3683 x 1981	6248
12000	23	5	8	54	32	42	48	940	220	152 x 78	21 - 6
5443	584	127	203	1372	813	1067	1219	6064.9	1419.4	3861 x 1981	6553
16000	26	5	8	57	34	44	51	1050	235	163 x 84	22 - 7
7258	660	127	203	1448	864	1118	1295	6774.6	1516.7	4140 x 2134	6883
20000	30	8	10	57	37	46	58	1190	278	171 x 88	23 - 6
9072	762	203	254	1448	940	1168	1473	7677.9	1793.6	4343 x 2235	7163
25000	34	8	10	60	39	50	62	1365	318	178 x 97	24 - 7
11340	864	203	254	1524	991	1270	1575	8806.9	2051.7	4521 x 2464	7493
35000	38	10	12	65	44	54	73	1665	396	185 x 100	26 - 9
15876	965	254	305	1651	1118	1372	1854	10742.6	2554.9	4699 x 2540	8153

*Bore is determined by steam or air conditions of installation. Dimensions shown are for pressures of 100 PSIG (7.03 Kg/cm²) at the hammer.

¹These minimum striking areas must be distributed evenly front-to-back and side-to-side. Data is predicated on using die blocks with hardness in the range of Rc 37-41. If softer blocks are used, proportionately larger areas must be used.



**1441 Chardon Road North
Cleveland, Ohio 44117
USA
216-531-1010 phone
216-481-6369 fax
www.ceco-ajax.com
sales-ceco-ajax@park-ohio.com**