

Modular High Capacity Refrigerated Dryers

TK - TM SERIES

3150 cfm - 12,500 cfm



The Dry Air Solution for Large Systems

Large compressed air systems present unique challenges for air treatment. Varying production needs means uneven compressed air volume use. Variable demand combined with lower ambient and inlet air temperatures results in a reduced load on any compressed air dryer.

For non-cycling dryers, although the dryer may not need to operate continually, it still runs constantly, significantly increasing unnecessary power consumption. Multiple, separate dryers that are individually piped can add to pressure drop across the system and increase the likelihood of leaks in the connecting piping runs.

Too often, large systems are not designed with redundancy in mind since adding another full-size dryer and the necessary piping takes up valuable floor space. However, when the air treatment components are down or even taken offline for routine maintenance, the air supply is interrupted, causing production downtime. Large systems often face a similar problem as their compressed air system grows — despite increased demand, there simply is not enough room to add additional air treatment components.

Kaeser's modular high capacity refrigerated dryers offer the perfect solution for large compressed air systems. They remove moisture, oil, and contaminants to consistently deliver clean, dry air. The modular design provides redundancy for critical applications which ensures uninterrupted air supply when a module is removed from operation. Additional modules can easily be added to the system as compressed air demand grows. The modular design also eliminates longer piping runs between dryer units and prevents unnecessary pressure drop. Finally, the digital scroll technology maximizes energy efficiency by matching the electrical power consumed in direct proportion to the incoming air demand.

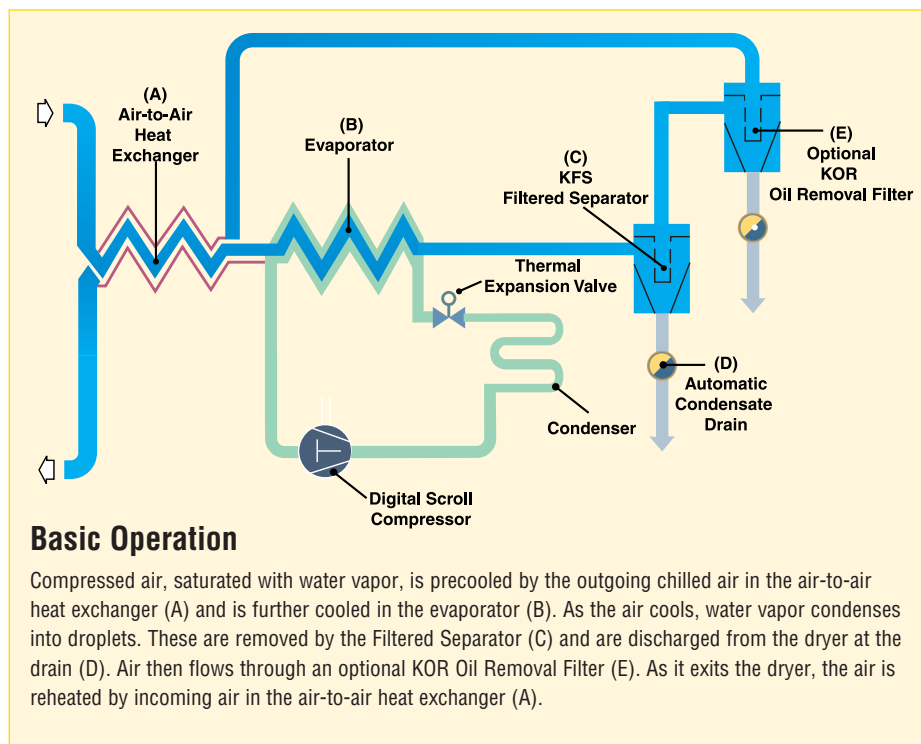

1 Controller

The Master Energy Monitor (mem™) is an intuitive operator interface that monitors system performance, tracks energy savings, and actively controls the individual dryer modules.



Features



2 Non-Fouling Heat Exchangers

Dryer modules feature non-fouling 316 stainless steel, copper brazed, plate type heat exchangers. The heat exchanger surface is stamped with a chevron pattern for extremely efficient heat transfer and durability. The smooth flow and self-cleaning design, eliminates the need for pre-filtration in most

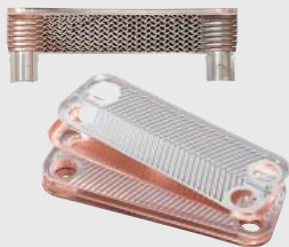

applications. The heat exchangers are encased in foam insulation to retain maximum energy efficiency while also minimizing the potential of cooling media temperature degradation. This advanced design offers superior performance and reliability.

3 Scroll Refrigeration Compressor

To maximize energy savings potential, we use digital scroll compressors.



With fewer moving parts and no valves, these compressors are very reliable, durable, and are maintenance friendly. Digital scroll compressors unload during reduced or low air demand for proportional energy savings at all loads down to 10% of the dryer's total capacity.

4 Integrated Coalescing Filtered Separator

Once compressed air is cooled, the condensed moisture must be removed from the air stream. To save space and reduce installation costs, the Kaeser Filtered Separator (KFS) is standard on each module. The KFS has two stages to remove bulk liquid and solid particles. The first stage uses two perforated stainless steel tubes for mechanical separation. The second stage uses in-depth fiber media to capture solid size particles and liquid droplets down to 3 microns in size. Unlike many other separators, the KFS is effective over a wide range of velocities/air flows.

5 Automatic Condensate Drain

Each module is equipped with a no-loss Eco-Drain to remove condensed moisture from the KFS. This electronic drain only activates when liquid is present, eliminating compressed air loss.

6 Integrated Cold Coalescing Oil Removal Filter (Optional)

For even cleaner compressed air, we highly recommend the optional integrated coalescing Kaeser Oil Removal (KOR) filter. This highly effective filter uses in-depth fiber media in two stages to trap and reduce oil aerosols to 0.01 ppmw and provides solid particle removal meeting ISO Class 2. The KOR filter is located at the coldest point in the system for maximum removal of oil aerosols. This option is incorporated inside the dryer cabinet and further reduces your space requirements and installation costs.



3150-5000 cfm



5250-7500 cfm



7350-10,000 cfm



10,500-12,500 cfm

Easy Installation and Service Accessibility

Kaeser's modular design offers numerous installation options and the added benefit of simplified maintenance access. Modules are joined with a common stainless steel inlet/outlet header sized for maximum air flow and minimum system pressure drop. Headers may be capped at either end, offering dual installation capability and modules are ready for left to right or right to left installation.

Each module has air-side isolation valves so individual modules can be serviced without disrupting the system air flow. Service panels on the top, front, and back of each module make maintenance access quick and easy. Each has its own electrical disconnect switch, making it possible to safely service one module without de-energizing others.

Finally, the fully enclosed individual modules include fork channels in the base pan that make it easy to maneuver into tight spaces and through low clearances using only a pallet jack. No crane is required for installation.



Controls

Each module is equipped with at-a-glance LED indicators for power, fault, and alarm status. The system's master module is equipped with the mem™ (Master Energy Monitor) controller that actively communicates with each module in the system lineup. A membrane keypad with a full menu of universally recognized symbols makes it easy to selectively retrieve information from any given module. You can program parameters for predictive maintenance and predetermined times for module on and off times. Information is displayed on a highly visible LCD (liquid crystal display) screen with four lines, twenty character capability.

The monitor is equipped with a Modbus RS 485 interface and Ethernet with Modbus TCP/IP support for seamless integration into plant control/monitoring systems.

The mem™ also provides energy savings information such as:

- Instantaneous load (%)
- Cumulative energy savings
- Projected annual savings
- Average monthly load (%)
- Average daily load (%)

The controller enables you to monitor several critical status indicators on each module including:

- Operational module status
- Refrigerant suction temperature
- Refrigerant suction pressure
- Coldest air temperature
- Refrigerant discharge temperature
- Refrigerant discharge pressure

Faults and alarms are time-stamped and recorded. These include:

- Drain failure to discharge
- Crankcase heater current not detected

- Low refrigerant suction pressure
- High refrigerant discharge pressure
- High evaporator air temperature
- Routine maintenance interval expired (customer programmed)

The optional Enhanced Instrumentation Package includes the mem™ plus text display and warnings for:

- High inlet air temperature
- High cooling water temperature
- Low outlet air pressure



Measurable Energy Savings

In a typical manufacturing facility, up to 30% of the electricity consumed is for generating compressed air, but compressed air load profiles in most manufacturing facilities fluctuate.

Kaeser's Modular High Capacity Refrigerated Dryers provide cost-effective energy savings by matching electrical power consumption in direct proportion to air demand. Digital scroll compressors fully maximize energy savings potential. These compressors load and unload based on real-time demand. Since significantly less energy is consumed while unloading, it is possible to deliver proportional energy savings. Unlike non-cycling dryers, linear load matching is achieved from 0 to 100%.

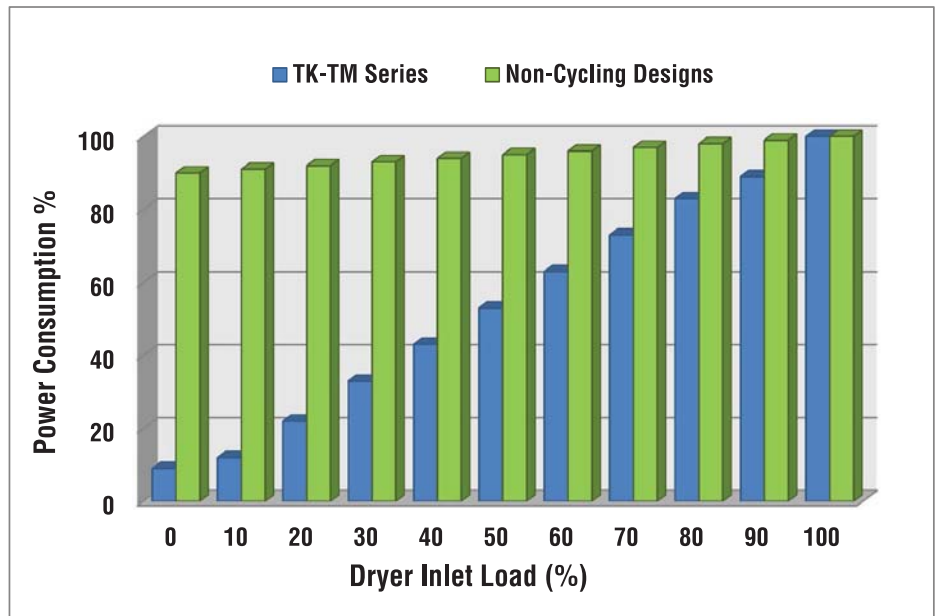

Selecting the Proper Dryer

To correctly size dryers for actual operating conditions, use these correction factors for inlet air pressure and temperature. Find the capacity correction factor corresponding to the inlet air conditions and multiply it by the dryer's rated capacity to determine its capacity at your operating conditions. Capacity correction factors for conditions not shown may be interpolated.

Correction Factors for Inlet Air Pressure and Temperature

Inlet Air Pressure (psig)	Inlet Air Temperature				
	90°F	100°F	110°F	120°F	130°F
30	0.92	0.71	0.56	0.44	0.35
50	1.07	0.83	0.66	0.54	0.44
80	1.19	0.95	0.77	0.63	0.52
100	1.25	1.00	0.82	0.68	0.56
125	1.31	1.05	0.86	0.72	0.61
150	1.34	1.08	0.90	0.75	0.64
175	1.37	1.11	0.92	0.78	0.66
200	1.39	1.14	0.95	0.80	0.68

Specifications

Air-cooled models

Model	Rated Flow (1) (scfm)	No. of Modules (2)	Available Voltages (V/ph/Hz) (3)	In/Out Connection	Overall Dimensions W x D x H (in.)	Total Weight (lbs.)
TK 890A	3150	2	Standard: 460/3/60 Optional: 575/3/60 230/3/60	8" Flange	85 x 81 x 128	3720
TK 1190A	4200					3894
TL 1490A	5250	3		10" Flange	125-3/8 x 81 x 128	5656
TL 1790A	6300					5830
TM 2080A	7350	4		12" Flange	163-3/4 x 81 x 128	7592
TM 2380A	8400					7766
TM 2675A	9450	5	202-1/8 x 81 x 128		9528	
TM 2975A	10,500				9702	

Water-cooled models

Model	Rated Flow (1) (scfm)	No. of Modules (2)	Available Voltages (V/ph/Hz) (3)	In/Out Connection	Water Flow @ 85°F (gpm)	Water Supply Conn.	Overall Dimensions W x D x H (in.)	Total Weight (lbs.)
TK 1060	3750	2	Standard: 460/3/60 Optional: 575/3/60 230/3/60	8" Flange	19	1-1/2" NPT (F)	85 x 81 x 95-7/8	3391
TK 1420	5000				26			3474
TL 1770	6250	3		10" Flange	32		125-3/8 x 81 x 95-7/8	5412
TL 2120	7500				39			5624
TM 2480	8750	4		12" Flange	45		163-3/4 x 81 x 95-7/8	7664
TM 2830	10,000				52			7876
TM 3190	11,250	5		58	202-1/8 x 81 x 95-7/8	9623		
TM 3540	12,500			65		9836		

Maximum Working Pressure: 232 psig

Minimum Working Pressure: 30 psig

Maximum Inlet Air Temperature: 130°F

Minimum Inlet Air Temperature: 40°F

Maximum Ambient Air Temperature: 110°F

Minimum Ambient Air Temperature: 40°F

Dryers meet agency approvals: CSA (CAN/CSA-C22.2 No. 236-95) - Heating and Cooling Equipment and UL Standard No. 1995.

Digital scroll compressors utilize environmentally friendly R404a refrigerant.

Canadian Registration Numbers - standard separator vessel and optional cold coalescing housing.

Standard separators include one vessel and are equipped with an electric demand drain. Units with optional cold coalescing filters are equipped with a dedicated electric demand drain - one per housing.

(1) Rated flow Capacity - Conditions for rating dryers are in accordance with ISO 7183 (option A2) working conditions: inlet air temperature 100°F (38°C), inlet air pressure 100 psig, cooling water temperature 85°F (29°C), 100% saturated air.

(2) Individual modules are combined in 1250 scfm and 2500 scfm increments to provide the desired flow capacity.

(3) Optional Voltages: 575/3/60 requirements utilize module-mounted transformers to step-down incoming power to 460/3/60; 230/3/60 requirements utilize module-mounted transformers to step-up to 460/3/60.

The Air Systems Specialist

We strive to earn our customers' trust by supplying superior quality equipment and services. Our products are designed for reliable performance, easy maintenance, and energy efficiency. Prompt and dependable customer service, quality assurance, training, and engineering support contribute to the value our customers have come to expect from Kaeser. Our employees are committed to implementing and maintaining the highest standards of quality to merit customer satisfaction. We aim for excellence in everything we do.

Our engineers continue to refine manufacturing techniques and take full advantage of the newest machining innovations. Extensive commitment to research and development keeps our products on the leading edge of technology to benefit our customers. Our industry-leading controls continue to set the standard for efficient system operation. With over 90 years of experience, Kaeser is the air systems specialist.

Kaeser Compressors, Inc.

511 Sigma Drive
Fredericksburg, Virginia 22408 USA
Phone: 540-898-5500
Toll Free: 800-777-7873
Email: info.usa@kaeser.com

Certified Management Systems



Kaeser Compressors Canada Inc.

3760 La Verendrye Street
Boisbriand, QC J7H 1R5 CANADA
Telephone: (450) 971-1414
Toll free: (800) 477-1416
info.canada@kaeser.com

Kaeser Compresores de México S de RL de CV

Calle 2 #123
Parque Industrial Jurídica
76100 Querétaro, Qro.
Telephone: 01 (442) 218 64 48
sales.mexico@kaeser.com

Kaeser Compresores de Guatemala y Cia. Ltda.

Calz. Atanasio Tzul 21-00, zona 12
El Cortijo II, Bodega 501
01012-Guatemala City
Telephone: +502 2412-6000
info.guatemala@kaeser.com

