

# RS45-46 SERIES



STRONG PARTNERS.  
TOUGH TRUCKS.™

**TECHNICAL GUIDE**  
High Capacity ReachStacker

# DIMENSIONS

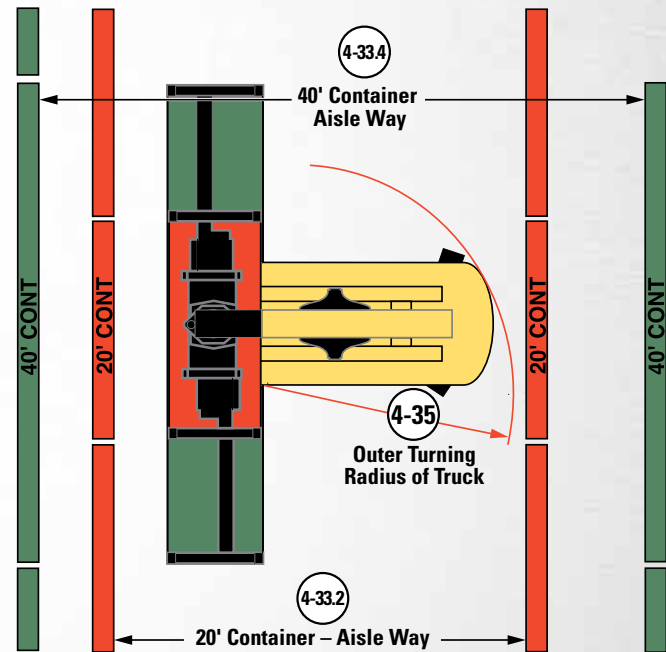
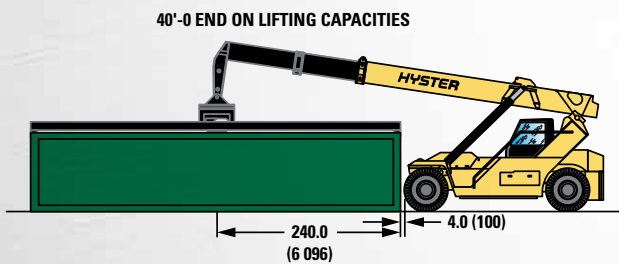
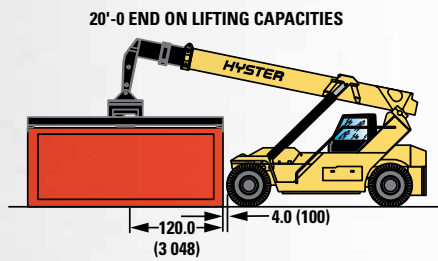
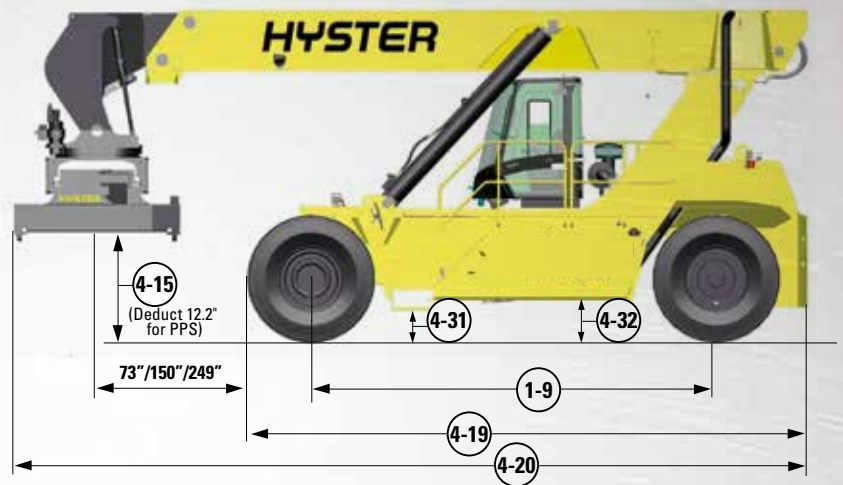
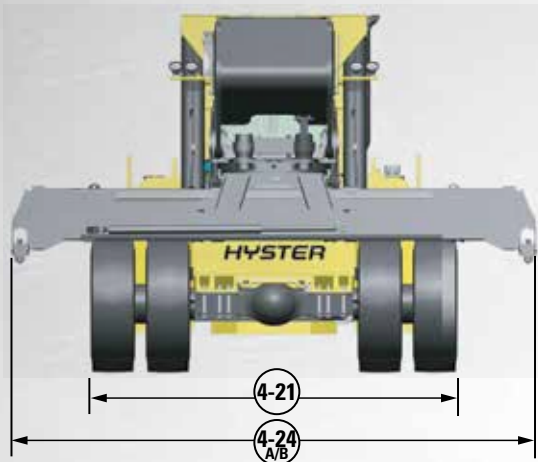

MAXIMUM CAPACITY CONTAINER PICKING END TO END		
MODEL	20'	40'
RS45-27	70,500 lb/32,000 kg	30,900 lb/14,000 kg
RS45-31	77,200 lb/35,000 kg	35,300 lb/16,000 kg
RS46-36	92,600 lb/42,000 kg	44,100 lb/20,000 kg
RS46-41S	99,000 lb/44,900 kg	58,000 lb/26,300 kg
RS46-41L	99,000 lb/44,900 kg	58,000 lb/26,300 kg
RS46-41LS	99,000 lb/44,900 kg	67,000 lb/30,300 kg

POWERTRAINS		Diesel		Diesel		Diesel	
1-3	Power type	Cummins QSL 9		Cummins QSM 11		Cummins QSM 11	
7-1	Engine manufacturer / model	Tier 4 Final		Tier 3 - 365 hp		Tier 3 - 300 hp	
	EPA tier compliance						
7-2	Engine power output - rated	hp	kW	350	261	335	250
	Engine power output - peak	hp	kW	363	271	365	272
7-3	Governed speed	rpm		2,100		2,100	
7-4	Number of cylinders / displacement	# / liters		6 / 8.9		6 / 10.8	
7-5	Engine torque - max	lb-ft	N-m	1,100	1,491	1,235	1,674
	Turbocharger	Type		Variable Geometry, Water cooled		Wastegate, Water cooled	Wastegate, Water cooled
7-9	Alternator output	Amps		120		120	
8-0	Transmission manufacturer / model	SOH TE 32		SOH TE 32		SOH TE 27	
8-1	Transmission type & speeds	Powershift 4F x 4R		Powershift 4F x 4R		Powershift 4F x 4R	
	Drive axle manufacturer / model	Kessler D102		Kessler D102		Kessler D102	

# LIFTING CAPACITY

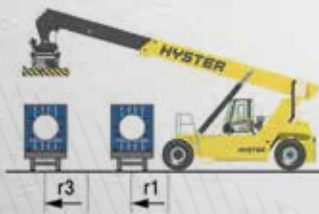
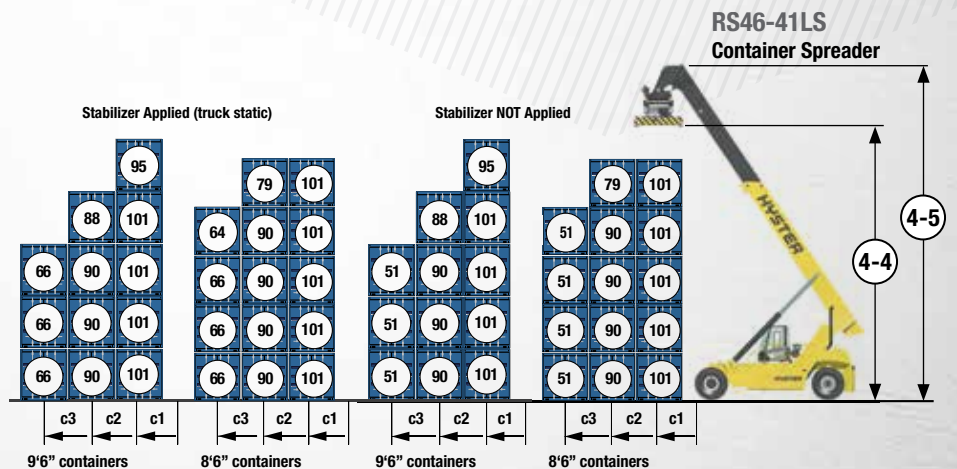
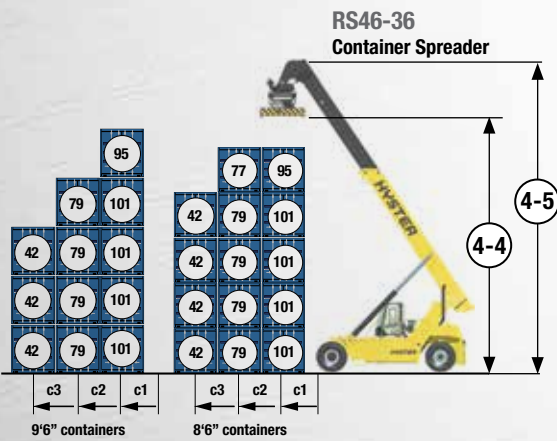
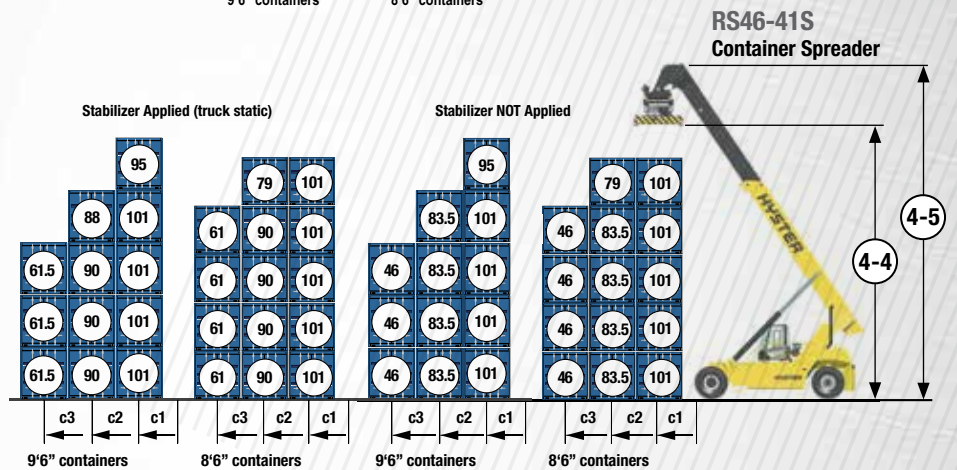
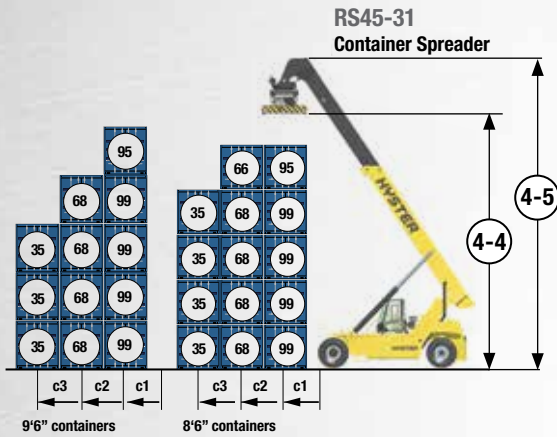
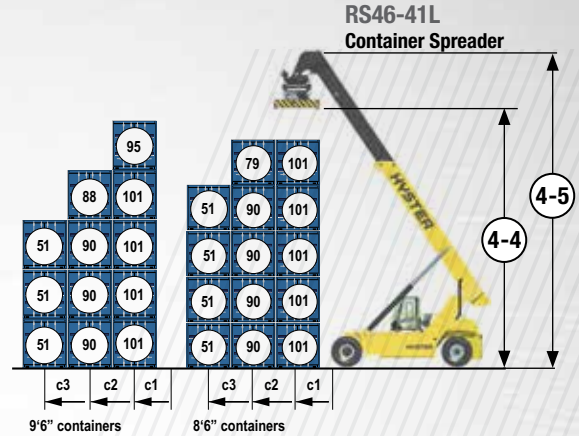
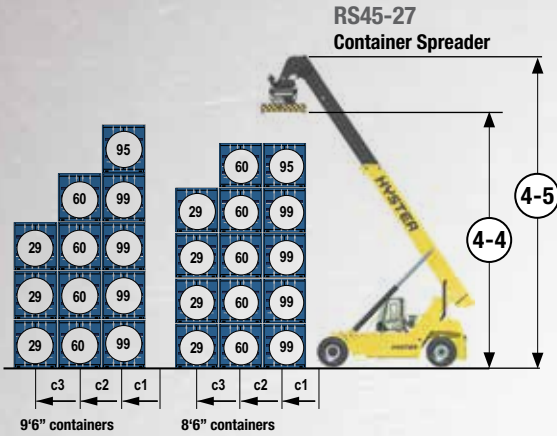

Handling in second rail

Note: All load centers c1, c2, c3 are taken from the front face of the (front) tires, deduct 3.9" for load centers taken from the front face of the stabilizer.

C1	C2	C3
73"	150"	249"

r1	r3
73"	252"

ReachStackers rated with manual pile slope spreader

\*Deduction for using the powered pile slope spreader is approximately 2,000 pounds.

# RS45-27 / RS45-31 / RS46-36 SPECIFICATIONS

		Description	Units	English	Metric	English	Metric	English	Metric
<b>GENERAL</b>	1-1	Manufacturer		Hyster		Hyster		Hyster	
	1-2	Model designation		RS45-27		RS45-31		RS46-36	
	1-3	Powertrain / Drivetrain		Diesel		Diesel		Diesel	
	1-4	Transmission type		Auto - Powershift		Auto - Powershift		Auto - Powershift	
	1-5a	Load capacity at load center distance c1	in (mm)	99,208	45,000	99,208	45,000	101,413	46,000
	1-5b	Load capacity at load center distance c2	in (mm)	59,525	27,000	68,343	31,000	79,366	36,000
	1-5c	Load capacity at load center distance c3	in (mm)	28,660	13,000	35,274	16,000	41,888	19,000
	1-5.1s	Load capacity at load center distance c1 (stabilizer applied)	in (mm)	—	—	—	—	—	—
	1-5.2s	Load capacity at load center distance c2 (stabilizer applied)	in (mm)	—	—	—	—	—	—
	1-5.3s	Load capacity at load center distance c3 (stabilizer applied)	in (mm)	—	—	—	—	—	—
	1-6a	Load center distance c1	in (mm)	73	1,865	73	1,865	73	1,865
	1-6b	Load center distance c2	in (mm)	150	3,815	150	3,815	150	3,815
	1-6c	Load center distance c3	in (mm)	249	6,315	249	6,315	249	6,315
	1-9	Wheelbase	in (mm)	244	6,200	244	6,200	244	6,200
<b>WEIGHT</b>	1-10	Stacking height		5 x 9' 6"		5 x 9' 6"		5 x 9' 6"	
	2-1	Service weight	lbs (kg)	151,017	68,500	159,174	72,200	174,827	79,300
	2-2a	Axle loading with load, front at c1	lbs (kg)	220,242	99,900	219,580	99,600	227,517	103,200
			rear at c1	lbs (kg)	29,983	13,600	38,801	17,600	48,722
	2-3a	Axle loading without load, front at c1	lbs (kg)	77,823	35,300	77,162	35,000	80,469	36,500
rear at c1			lbs (kg)	73,193	33,200	82,012	37,200	94,358	42,800
<b>WHEELS</b>	3-1	Tire type		Pneumatic		Pneumatic		Pneumatic	
	3-2	Tire size	front	18.00 x 25-40PR		18.00 x 25-40PR		18.00 x 33-36PR	
			rear	18.00 x 25-40PR		18.00 x 25-40PR		18.00 x 33-36PR	
3-3			18.00 x 25-40PR		18.00 x 25-40PR		18.00 x 33-36PR		
<b>DIMENSIONS</b>	4-1	Boom angle minimum / maximum	degrees	0	59	0	59	0	59
	4-2	Height of boom lowered	in (mm)	185	4,700	185	4,700	189	4,795
	4-4a	Lift height at load center c1	in (mm)	601	15,260	601	15,260	605	15,355
	4-4b	Lift height at load center c2	in (mm)	545	13,850	545	13,850	549	13,945
	4-4c	Lift height at load center c3	in (mm)	90	2,280	90	2,280	90	2,280
	4-5	Height, boom extended	in (mm)	713	18,110	713	18,110	717	18,205
	4-7	Height of overhead guard (cabin)	in (mm)	146	3,720	146	3,720	150	3,815
	4-15	Height below spreader, lowered	in (mm)	53	1,345	53	1,345	57	1,440
	4-19	Overall length, chassis	in (mm)	329	8,360	329	8,360	341	8,650
	4-20	Overall length including boom retracted	in (mm)	467	11,873	467	11,873	475	12,073
	4-21	Overall width over drive tires	in (mm)	165	4,200	165	4,200	165	4,200
	4-23a	Spreader		ISO 20' - 40'		ISO 20' - 40'		ISO 20' - 40'	
	4-23b	Pile slope		Mechanical +/-3°		Mechanical +/-3°		Mechanical +/-3°	
	4-24a	Overall width with 20' container	in (mm)	240	6,100	240	6,100	240	6,100
	4-24b	Overall width with 40' container	in (mm)	480	12,200	480	12,200	480	12,200
	4-31	Ground clearance, lowest point	in (mm)	11.2	285	11.2	285	12.0	304
	4-32	Ground clearance, center of wheelbase	in (mm)	17.2	437	17.2	437	20.9	532
	4-33a	Minimum aisle width for 20' container without operating clearance	in (mm)	386	9,817	386	9,817	393	9,977
	4-33b	Minimum aisle width for 20' container (incl 10% clearance)	in (mm)	539	13,683	539	13,683	539	13,689
	4-33c	Minimum aisle width for 40' container without operating clearance	in (mm)	495	12,569	495	12,569	495	12,569
	4-33d	Minimum aisle width for 40' container (incl 10% clearance)	in (mm)	615	15,623	615	15,623	615	15,623
	4-35	Outside turning radius	in (mm)	334	8,495	334	8,495	337	8,562
	5-10	Service brake		Oil immersed (wet) disc		Oil immersed (wet) disc		Oil immersed (wet) disc	
5-11	Park brake		Spring apply, dry disc		Spring apply, dry disc		Spring apply, dry disc		
8-7	Hydraulic tank capacity	gal liter	46	174	46	174	46	174	
8-8	Fuel tank capacity	gal liter	219	830	219	830	219	830	
10-4	DEF Tank capacity	gal liter	15	56	15	56	15	56	

\* Deduct 12.2" with powered pile slope option

\*\* Load capacities shown with mechanical pile slope (MPS) spreader. Deduction for using powered pile slope spreader is approximately 2,000 lbs.

NOTE: Above specifications, unless otherwise listed, are for a standard truck without optional equipment.

CERTIFICATION: These Hyster® lift trucks meet design specifications of Part II ANSI B56.1-1969, as required by OSHA Section 1910.178(a)(2) and also comply with Part III ANSI B56.1-revision in effect at time of manufacture. Certification of compliance with the applicable ANSI standards appears on the lift truck. Performance specifications are for a truck equipped as described under Standard Equipment on this Technical Guide. Performance specifications are affected by the condition of the vehicle and how it is equipped, as well as by the nature, condition of the operating area, proper service and maintenance of the vehicle. If these specifications are critical, the proposed application should be discussed with your dealer.

# RS46-41L / RS46-41S / RS46-41LS SPECIFICATIONS

		Description	Units	English	Metric	English	Metric	English	Metric
GENERAL	1-1	Manufacturer		Hyster		Hyster		Hyster	
	1-2	Model designation		RS46-41L		RS46-41S		RS46-41LS	
	1-3	Powertrain / Drivetrain		Diesel		Diesel		Diesel	
	1-4	Transmission type		Auto - Powershift		Auto - Powershift		Auto - Powershift	
	1-5a	Load capacity at load center distance c1	in (mm)	101,413	46,000	101,413	46,000	101,413	46,000
	1-5b	Load capacity at load center distance c2	in (mm)	90,390	41,000	83,776	38,000	90,390	41,000
	1-5c	Load capacity at load center distance c3	in (mm)	50,706	23,000	46,297	21,000	50,706	23,000
	1-5.1s	Load capacity at load center distance c1 (stabilizer applied)	in (mm)	—	—	101,413	46,000	101,413	46,000
	1-5.2s	Load capacity at load center distance c2 (stabilizer applied)	in (mm)	—	—	90,390	41,000	90,390	41,000
	1-5.3s	Load capacity at load center distance c3 (stabilizer applied)	in (mm)	—	—	61,729	28,000	66,139	30,000
	1-6a	Load center distance c1	in (mm)	73	1,865	73	1,865	73	1,865
	1-6b	Load center distance c2	in (mm)	150	3,815	150	3,815	150	3,815
	1-6c	Load center distance c3	in (mm)	249	6,315	249	6,315	249	6,315
	1-9	Wheelbase	in (mm)	264	6,700	244	6,200	264	6,700
WEIGHT	1-10	Stacking height		5 x 9' 6"		5 x 9' 6"		5 x 9' 6"	
	2-1	Service weight	lbs (kg)	182,102	82,600	184,306	83,600	186,511	84,600
	2-2a	Axle loading with load, front at c1	lbs (kg)	227,958	103,400	232,367	105,400	232,808	105,600
			rear at c1	lbs (kg)	55,556	25,200	53,352	24,200	55,116
2-3a	Axle loading without load, front at c1	lbs (kg)	84,217	38,200	85,319	38,700	89,067	40,400	
		rear at c1	lbs (kg)	97,885	44,400	98,988	44,900	97,444	44,200
WHEELS	3-1	Tire type		Pneumatic		Pneumatic		Pneumatic	
	3-2	Tire size front		18.00 x 33-36PR		18.00 x 33-36PR		18.00 x 33-36PR	
	3-3	Tire size rear		18.00 x 33-36PR		18.00 x 33-36PR		18.00 x 33-36PR	
DIMENSIONS	4-1	Boom angle minimum / maximum	degrees	0	59	0	59	0	59
	4-2	Height of boom lowered	in (mm)	189	4,795	189	4,795	189	4,795
	4-4a	Lift height at load center c1	in (mm)	605	15,355	605	15,355	605	15,355
	4-4b	Lift height at load center c2	in (mm)	549	13,945	549	13,945	549	13,945
	4-4c	Lift height at load center c3	in (mm)	90	2,280	90	2,280	90	2,280
	4-5	Height, boom extended	in (mm)	717	18,205	717	18,205	717	18,205
	4-7	Height of overhead guard (cabin)	in (mm)	150	3,815	150	3,815	150	3,815
	4-15	Height below spreader, lowered	in (mm)	57	1,440	57	1,440	57	1,440
	4-19	Overall length, chassis	in (mm)	360	9,150	344	8,750	364	9,250
	4-20	Overall length including boom retracted	in (mm)	495	12,573	475	12,073	495	12,573
	4-21	Overall width over drive tires	in (mm)	165	4,200	165	4,200	165	4,200
	4-23a	Spreader		ISO 20' - 40'		ISO 20' - 40'		ISO 20' - 40'	
	4-23b	Pile slope		Mechanical +/-3°		Mechanical +/-3°		Mechanical +/-3°	
	4-24a	Overall width with 20' container	in (mm)	240	6,100	240	6,100	240	6,100
	4-24b	Overall width with 40' container	in (mm)	480	12,200	480	12,200	480	12,200
	4-31	Ground clearance, lowest point	in (mm)	12.0	304	9.8	250	9.8	250
	4-32	Ground clearance, center of wheelbase	in (mm)	20.9	532	20.9	532	20.9	532
	4-33a	Minimum aisle width for 20' container without operating clearance	in (mm)	412	10,477	393	9,977	412	10,477
	4-33b	Minimum aisle width for 20' container (incl 10% clearance)	in (mm)	539	13,689	539	13,689	539	13,689
	4-33c	Minimum aisle width for 40' container without operating clearance	in (mm)	495	12,569	495	12,569	495	12,569
	4-33d	Minimum aisle width for 40' container (incl 10% clearance)	in (mm)	615	15,623	615	15,623	615	15,623
4-35	Outside turning radius	in (mm)	357	9,062	337	8,562	357	9,062	
5-10	Service brake		Oil immersed (wet) disc		Oil immersed (wet) disc		Oil immersed (wet) disc		
5-11	Park brake		Spring apply, dry disc		Spring apply, dry disc		Spring apply, dry disc		
8-7	Hydraulic tank capacity	gal liter	174	660	174	660	174	660	
8-8	Fuel tank capacity	gal liter	219	830	219	830	219	830	
10-4	DEF Tank capacity	gal liter	15	56	15	56	15	56	

\* Deduct 12.2" with powered pile slope option

\*\* Load capacities shown with mechanical pile slope (MPS) spreader. Deduction for using powered pile slope spreader is approximately 2,000 lbs.

NOTE: Above specifications, unless otherwise listed, are for a standard truck without optional equipment.

CERTIFICATION: These Hyster® lift trucks meet design specifications of Part II ANSI B56.1-1969, as required by OSHA Section 1910.178(a)(2) and also comply with Part III ANSI B56.1-revision in effect at time of manufacture. Certification of compliance with the applicable ANSI standards appears on the lift truck. Performance specifications are for a truck equipped as described under Standard Equipment on this Technical Guide. Performance specifications are affected by the condition of the vehicle and how it is equipped, as well as by the nature, condition of the operating area, proper service and maintenance of the vehicle. If these specifications are critical, the proposed application should be discussed with your dealer.

# PERFORMANCE SPECIFICATIONS

GENERAL	Description		Units		English	Metric	English	Metric	English	Metric	English	Metric	English	Metric	English	Metric
	1-1	Manufacturer			Hyster		Hyster		Hyster		Hyster		Hyster		Hyster	
	1-2	Model designation			RS45-27		RS45-31		RS46-36		RS46-41L		RS46-41S		RS46-41LS	
	1-3	Powertrain / Drivetrain			Diesel		Diesel		Diesel		Diesel		Diesel		Diesel	
	1-4	Transmission type			Auto - Powershift		Auto - Powershift		Auto - Powershift		Auto - Powershift		Auto - Powershift		Auto - Powershift	
PERFORMANCE	PERFORMANCE		WITH TIER 4 FINAL CUMMINS QSL 9 ENGINE - TE 32 TRANSMISSION													
	5-1a	Travel speed with load	mph	km/h	12.4	20	12.4	20	13.0	21	13.0	21	13.0	21	13.0	21
	5-1b	without load	mph	km/h	13.7	22	13.7	22	14.3	23	14.3	23	14.3	23	14.3	23
	5-2a	Lifting speed with load	ft/min	m/s	55	0.28	55	0.28	55	0.28	55	0.28	55	0.28	55	0.28
	5-2b	without load	ft/min	m/s	94	0.48	94	0.48	94	0.48	94	0.48	94	0.48	94	0.48
	5-3a	Lowering speed with load	ft/min	m/s	91	0.46	91	0.46	91	0.46	91	0.46	91	0.46	91	0.46
	5-3b	without load	ft/min	m/s	98	0.50	98	0.50	98	0.50	98	0.50	98	0.50	98	0.50
	5-5	Drawbar pull - 1 mph (1.6 km/h)	lbs	kN	81,606	363	81,381	362	81,381	362	73,962	329	81,381	362	73,962	329
	5-6	Drawbar pull - max	lbs	kN	97,114	432	96,889	431	85,874	382	85,424	380	84,424	380	85,424	380
	5-7	Gradeability no load / rated load - 1 mph (1.6 km/h)	%		35 / 26	35 / 26	35 / 25	35 / 25	33 / 23	33 / 23	33 / 23	32 / 21	32 / 21	32 / 21	32 / 21	32 / 21
	PERFORMANCE		WITH TIER 3 CUMMINS QSM 11 365HP ENGINE - TE 32 TRANSMISSION													
	5-1a	Travel speed with load	mph	km/h	13.0	21	13.0	21	14.3	23	12.4	20	12.4	20	12.4	20
	5-1b	without load	mph	km/h	14.3	23	14.3	23	16.2	26	14.9	24	14.9	24	14.9	24
	5-2a	Lifting speed with load	ft/min	m/s	55	0.28	55	0.28	55	0.28	55	0.28	55	0.28	55	0.28
	5-2b	without load	ft/min	m/s	94	0.48	94	0.48	94	0.48	94	0.48	94	0.48	94	0.48
	5-3a	Lowering speed with load	ft/min	m/s	91	0.46	91	0.46	91	0.46	91	0.46	91	0.46	91	0.46
	5-3b	without load	ft/min	m/s	98	0.50	98	0.50	98	0.50	98	0.50	98	0.50	98	0.50
	5-5	Drawbar pull - 1 mph (1.6 km/h)	lbs	kN	61,598	274	61,598	274	55,528	247	55,528	247	55,528	247	55,528	247
	5-6	Drawbar pull - max	lbs	kN	97,114	432	96,889	431	85,874	382	85,424	380	85,424	380	85,424	380
	5-7	Gradeability no load/rated load - 1 mph (1.6 km/h)	%		35 / 26	35 / 26	35 / 25	35 / 25	33 / 23	33 / 23	32 / 21	32 / 21	32 / 21	31 / 21	31 / 21	31 / 21
	PERFORMANCE		WITH TIER 3 CUMMINS QSM 11 300HP ENGINE - TE 27 TRANSMISSION													
	5-1a	Travel speed with load	mph	km/h	12.4	20	12.4	20	12.4	20	11.8	19	11.8	19	11.8	19
	5-1b	without load	mph	km/h	14.3	23	14.3	23	15.5	25	13.7	22	13.7	22	13.7	22
	5-2a	Lifting speed with load	ft/min	m/s	49	0.25	49	0.25	49	0.25	49	0.25	49	0.25	49	0.25
	5-2b	without load	ft/min	m/s	94	0.48	94	0.48	94	0.48	94	0.48	94	0.48	94	0.48
	5-3a	Lowering speed with load	ft/min	m/s	91	0.46	91	0.46	91	0.46	91	0.46	91	0.46	91	0.46
	5-3b	without load	ft/min	m/s	98	0.50	98	0.50	98	0.50	98	0.50	98	0.50	98	0.50
5-5	Drawbar pull - 1 mph (1.6 km/h)	lbs	kN	61,598	274	61,598	274	55,528	247	55,528	247	55,528	247	55,528	247	
5-6	Drawbar pull - max	lbs	kN	61,597	274	61,598	274	61,598	274	61,598	274	61,598	274	61,598	274	
5-7	Gradeability no load/rated load - 1 mph (1.6 km/h)	%		36 / 22	36 / 22	36 / 22	36 / 22	34 / 19	34 / 19	32 / 18	32 / 18	32 / 18	32 / 18	34 / 19	34 / 19	

## ENGINE

- Tier 4 Final Cummins QSL 9L 363 hp (271 kW) peak power. Smooth torque of 1,200 lb-ft at 1000 – 1400 rpm provides excellent acceleration and power, together with low fuel consumption.
- Tier 3 Cummins QSM 11L 365 hp (272 kW) peak power. Torque available of 1235 ft-lbs (1634 Nm) at 1200 rpm with good fuel consumption.
- Tier 3 Cummins QSM 11L 300HP (224 kW) peak power. Torque available of 1050 ft-lbs (1424 Nm) at 1200 rpm.\*
- Engine protection system to protect against high temperature, low coolant level and high/low oil pressure.
- Fuel/water separator.

## AIR CLEANER

- Integrated heavy duty intake pre-cleaner (Tier 4 Final)
  - Packaged onto engine
  - Self-cleaning
  - Designed for long life
  - Capable of filtration in extreme duty applications and extreme weather conditions
- Sy-Klone pre-cleaner (Tier 3)
  - Self-cleaning
  - Extends air filter life, which increases uptime
  - Handles all kinds of mixed debris, including mud, snow, rain, leaves, sawdust, chaff, and dust

## COOLING SYSTEM

- Oversized cooling system includes:
  - Charge air cooler
  - Engine cooler
  - Hydraulic oil cooler
  - Transmission oil cooler
- Separate coolers for easy servicing
- Suitable up to 122° F ambient in normal operation
- Suitable up to 113° F ambient in extreme applications
- Hydraulically driven on-demand cooling fan

## ELECTRICAL

- Engineered to meet UL 558 requirements
- CANbus communication allows the transmission, hydraulic system, engine, and dash display to communicate
- Environmentally sealed connectors used throughout system
- Silicone seals to prevent moisture in connections
- Thermoplastic housings for use in -67° F to 257° F
- Electrical panel located on right side of console
- Provisions for 40 fuses and 8 relays

## TRANSMISSION

- Spicer Off-Highway TE 32 4-speed autoshifting transmission
- Spicer Off-Highway TE 27 4-speed autoshifting transmission (available with 300HP Tier 3 engine option only)
- 4 speeds forward and reverse
- Fully electronically controlled
- APC 200 electronic controller
- Forward reverse lock out
  - Prevents change of direction at high speeds
- Transmission protection system to protect against high temperature and high/low oil pressure

## AUTOMATIC THROTTLE-UP

- Immediate response to lift inputs when the operator activates the joystick
- Only activated when the transmission is in the neutral position or when the inching pedal is fully depressed
- Engine automatically revs up when lifting
- Feature is disengaged when truck is in gear

## DRIVE AXLE

- Kessler Model D102 rigid planetary drive axle
  - Drive axle is bolted to the frame
- Outboard planetary end reductions
- Oil-immersed (wet) brakes on the drive axle feature oil cooling for durability and are virtually maintenance free

## STEER AXLE

- One-piece steer axle frame
- Large sealed, tapered roller bearings

## BRAKE SYSTEM

- Hydraulically actuated, oil cooled wet disc brakes
- Includes accumulator for dead-engine braking
- Premium oil filtration system
  - Brake filter 20 micron
- Oil cooling system
  - Cooled oil supplied by gear pump
  - Ensures maximum performance and long life
- Park brake composed of dry disc mounted to drive axle input shaft
  - Spring applied, hydraulic released
- Long life friction discs

## CHASSIS

- Single piece welded steel frame
  - Fewer components
  - Rigid construction
  - High strength steel

## HYDRAULIC SYSTEM

Hyster on-demand load-sensing hydraulic system introduces an efficient way to meet hydraulic load demands:

- Based on Variable Displacement Pump (VDP) technology.
- Pump is only active when oil is needed.
- Less heat is produced, helping oil and filters last longer. Hoses, seals, and components also wear less and last longer.
- Engine runs quieter and at lower speeds, extending life of major components.
- Leak free O-Ring Face Seals (ORFS) fittings standard throughout the truck.
- Capable of more oil displacement even at low engine speeds.

## BOOM AND ATTACHMENT

- Durable two stage, rectangular shaped boom
- Welded inside and out for added strength
- Inner boom constructed of T-1 steel
- Hyster 817 premium spreader
  - Mechanical pile slope
  - 20' to 40' expansion
  - +185° / -95° rotation
  - 31.5" sideshift each side (63" total)

\* Available in non-EPA regulated markets only.

# STANDARD FEATURES AND OPTIONS

## STANDARD EQUIPMENT

- Cummins QSL 9L 363 HP turbo diesel engine
  - Tier 4 Final compliant \*
  - ECO / eLo / HiP
  - Hibernate idle
  - Hydraulically driven cooling fan
- Spicer off-highway TE-32 4 speed auto-shifting transmission
- 2-stage boom
- Integrated spreader attachment, Hyster Model 817 with mechanical pile slope
- Wet disc brakes
- Planetary drive axle
- On-demand load sensing hydraulic system featuring variable displacement pump technology
- Directional control lever
- Steer wheel nut protection
- Enclosed operator compartment featuring:
  - Seat-side, joystick hydraulic control
  - Multi-functional display panel
  - Telescoping & tilting steering column
  - Floor mat
  - 24-12V DC converter
  - Isolated mounting for low noise and vibration
  - Handrails for operator entry and exit (left side)
  - Steering wheel spinner knob
  - Electronic horn (105 dBA)
  - Heater with 3-speed fan
  - Front and rear window defrosters
  - Overhead and rear sunshades
  - Intermittent single front wiper
  - Top and rear wipers
  - Recirculation fan
  - 3B6 load moment indicator with monochrome display
  - Mechanical, full suspension cloth seat with integrated adjustable armrest and seat belt
  - Electronic twist lock position indicator with LED signals and audible tone (TWIST Module)
  - Interior wide angle mirrors
  - External wide angle mirrors – mounted on front fenders
  - Operator restraint system
  - Operator presence system
- Lockable battery disconnect switch
- Integrated heavy duty air intake pre-cleaner
- 24-volt electrical system
- 219 gallon fuel tank
- 174 gallon hydraulic tank
- 15 gallon DEF tank
- 120 amp alternator
- Lifting eyes to hoist complete truck less spreader

- Light kit 3, consisting of:
  - Front: 4 halogen work lights fender mounted  
2 marker lights  
4 halogen lights boom mounted
  - Rear: 2 rear mounted halogen lights  
2 stop/tail/backup lights  
Turn signal & hazard lights
  - Spreader: 2 halogen work lights on spreader
- Visible alarm – amber strobe light – key switch activated
- Audible alarm – reverse direction activated 82–102 dB(A)
  - self adjusting
- Non-locking fuel cap
- Literature package
  - Operator's manual
  - Service manual
  - Parts manual
- 12 months / 2,000 hours manufacturer's warranty

## OPTIONS

- Cummins QSM 11L 365 HP turbo diesel engine
  - Tier 3 compliant
- Cummins QSM 11L 300 HP turbo diesel engine
  - Tier 3 compliant (for non-EPA regulated markets only)
- Hyster Model 817 spreader options:
  - Powered pile slope
  - Powered dampening
  - WTP (Wide Twistlock Position)
  - 4 lifting eyes located under center beam of spreader
- Tire options – drive and steer:
  - 18.00 x 25 – 40 bias ply slick (STMS LS5)
  - 18.00 x 25 – 40 bias ply treaded
  - 18.00 x 33 – 36 ply
- Seat options:
  - Air ride, full suspension cloth seat with high back rest
  - Deluxe air ride full suspension cloth seat
  - Deluxe air ride full suspension cloth seat with heated seat cushion
- 3B6 load moment indicator with color display
- Adjustable traction speed limiter – factory pre-set to 8 mph
- Adjustable automatic engine shutdown
- Air conditioning
- Right hand side stairway and handrails
- Auto greasing system
  - Basic truck / outer boom
  - Spreader / inner boom
- Hydraulic sliding cab
- High intensity discharge - xenon (HID) lights

\* Requires ultra-low sulfur diesel fuel and low-ash engine oil



Hyster Company  
P.O. Box 7006  
Greenville, North Carolina  
27835-7006  
Part No. RS45-46/TG  
10/2014 Litho in U.S.A.

Visit us online at [www.hyster.com](http://www.hyster.com) or call us at 1-800-HYSTER-1.

Hyster and  are registered trademarks of Hyster Company. Hyster products are subject to change without notice. Cummins, Sy-Klone, Spicer and Kessler are registered trademarks of their respective companies.

The Hyster Company products included in this document may be covered by US Patent 6,684,148, and other patents pending. All trucks shown with optional equipment. ©2014 Hyster Company. All rights reserved.