

INDEX

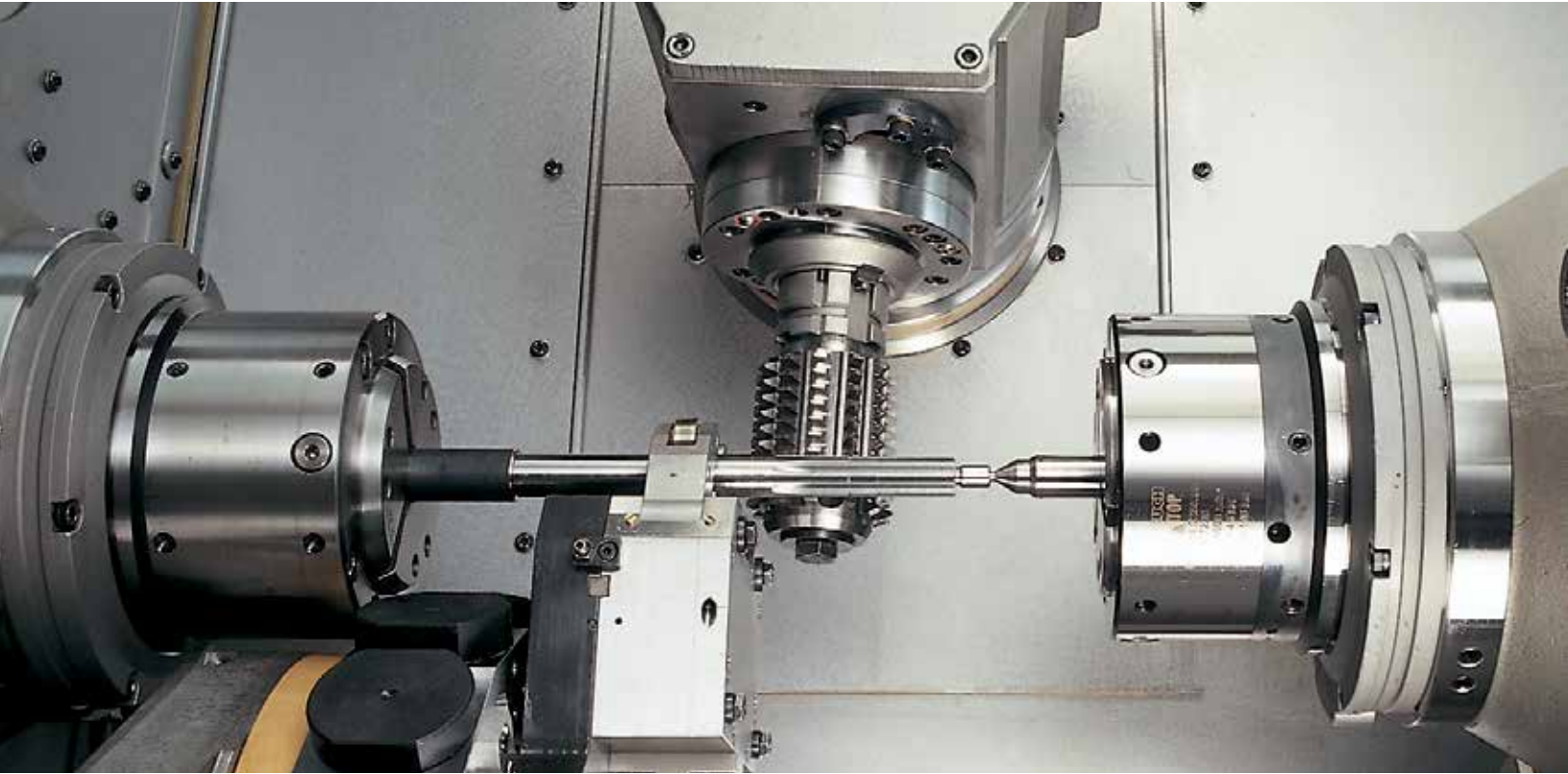

North American Package

**CNC Turn-Mill Center INDEX G200
with INDEX C200-4D control
including selected full features at an attractive price.**

One step ahead.

G200 – powerful turning and milling

For efficient complete machining of bar stock and chuck turning parts

- Powerful main and counter spindle (motorized spindles)
- Simultaneous machining using 2 turrets (14xVDI25)
- The Y-axis and B-axis - running in hydrostatic, play-free bearings and swivelable 360° can be used on the main and counter spindle
- Additional milling spindle (HSK-B50, 5.5kw, 55 Nm)
- INDEX W slot tooling on turrets 1 and 2
- Counter spindle with programmable tailstock function

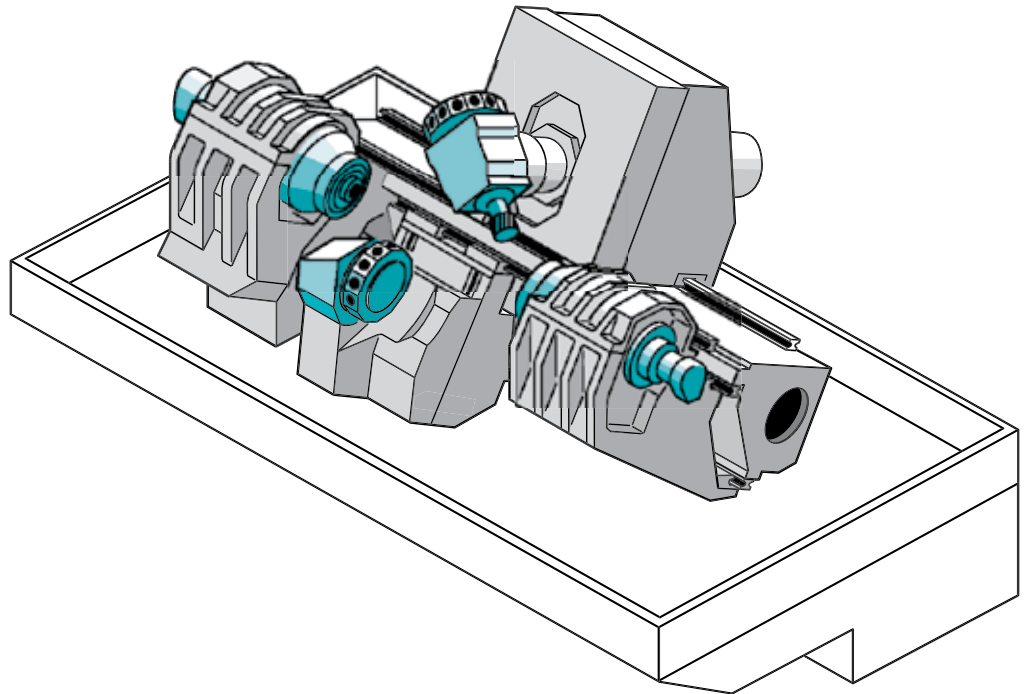

Example of a machine offer

with INDEX C200-4D control (Siemens 840D powerline)

- Main and counter spindle with bar capacity 60 mm max. speed 6,000 rpm, max. power 20/13 kW (100%)
- Stopper unit for counter spindle with integrated cooling lubricant line
- Remote adjustment of main and counter spindle clamping pressures from the CNC control
- Tool carrier 1 (X, Z, Y, B)
- Tool carrier 2 (X, Z)
- 28 tool stations VDI25 INDEX W slot tooling
- Tool drive for TC 1, 2 max. speed 6,000 rpm, max. power 5.5 kW (25%) max. torque 15 Nm (25%)
- Collet chuck for the main and sub spindle
- Milling spindle, max. speed 2,000 rpm max. power 5.5 kW, max. torque 55 Nm (25%)
- Workpiece removal unit with workpiece gripper
- Timed workpiece removal conveyor
- Slat band chip conveyor (1,250 mm discharge height)
- ECO fluid cooling lubricant system (8-80 bar, frequency-controlled) and ultra-fine cleaning (paper belt filter)
- Machine equipped for emulsion operation
- INDEX tool breakage and wear monitoring
- MBL and Unimag Bar loading interfaces for INDEX and third party bar loaders
- INDEX durable tooling package
- Line conditioning Transformer
- Initial Commissioning of machine
- 4 ½ days of operator training/assistance
- Shipping FOB INDEX Corporation

Custom workpiece setups not included, but can be quoted upon request

Please keep in mind that machine-specific and material-specific components, such as clamping devices, spindle reductions and accessories are also needed and are not included in the pricing.

INDEX Corporation

14700 North Pointe Blvd.
Noblesville, IN 46060
Tel. 317-770-6000
Fax 317-770-3166
email sales@index-usa.com
www.indextraub.com