



以**客户**为中心 让**控制**更简单
 Customer Focused Simplify Your Control

中国驱动器行业的领航者
 CHINA'S DRIVE LEADER



江苏吉泰科电气股份有限公司
 JIANGSU GTAKE ELECTRIC CO., LTD.

深圳市宝安区石岩塘头一号路中运泰科技工业园10栋
 Building 10,Zhong-yun-tai Industrial Park,Tangtou Road NO.1 Bao'an
 District,Shenzhen,Guangdong Province
 Tel: 86-0755-86392609 Fax: 86-0755-86392603
[Http://www.gtake.com.cn](http://www.gtake.com.cn)

编码 : 34.05.0003
 版本 : A01



江苏吉泰科电气股份有限公司
 JIANGSU GTAKE ELECTRIC CO., LTD.

公司简介
Company Profile

江苏吉泰科电气股份有限公司以自主知识产权的电力电子技术和电机控制技术为基础，致力于打造国际一流的技术平台，以行业内一流的产品和系统解决方案服务于国际、国内的中、高端客户。

Jiangsu GTAKE Electric Co., Ltd. by virtue of advanced power electronic and motor control technology with independent intellectual property rights, is committed to providing first rank products and system solutions derived from our internationalized technology platform, for me-dium and high-end customers worldwide.



公司专注于电力电子技术和电机控制技术，主要涵盖工业变频器、伺服驱动器、新能源汽车电机控制器、风力发电变流器和光伏逆变器产品的研发、生产和销售。

GTAKE focusing on power electronic and motor control technology is dedicated to R&D, production and sales of industrial AC motor drives, servo drives, new energy vehicle motor controllers, wind power converters, solar converters, etc.

“以客户为中心”是吉泰科的核心价值观，吉泰科以追求客户对我们产品的信赖为己任，让客户享受我们的质量与服务，最终实现打破国外品牌的垄断，从国内走向国际的企业使命。公司在经营方面秉承自主创新、精诚团结的企业精神，采用现代化企业经营理念，利用现代化管理工具，使企业的业务流程规范、高效。

With the core value "customer focused", we are in unremitting pursuit of customers trust by providing high-quality products and professional services. GTAKE resolves to break the monopoly of top alien brands in demanding applications, with our strong and vigorous steps in market deployment worldwide. We are adopting scientific principles, utilizing advanced management tools, to facilitate our business process standardized, and efficient, in the spirit of innovation and all staff solidarity.



GK800系列驱动器
GK800 Series High Performance AC Motor Drives

支持同步电机和异步电机驱动
有速度传感器和无速度传感器矢量控制
位置控制、速度控制和转矩控制
Synchronous and asynchronous motor supported
Speed-sensor control and speed-sensorless control programmable
Position control, speed control and torque control programmable



GK600系列变频器
GK600 Series General Purpose AC Motor Drives

无速度传感器矢量控制
Speed-sensorless control



GK500系列迷你型变频器
GK500 Series Mini AC Motor Drives

无速度传感器矢量控制
Speed-sensorless control



GK1000系列AFE能量回馈型变频器
GK1000 Series AFE Energy Feedback AC Motor Drives

四象限运行，能量实时回馈电网
Four-quadrant running, Real-time energy feedback



ES100系列节能一体柜
ES100 Series Energy Saving Cabinet Drives

同步/异步伺服控制
Asynchronous/Synchronous servo control



新能源汽车电机控制器
New Energy Vehicle Motor Controllers

支持同步电机和异步电机驱动
风冷和水冷可选
Synchronous and asynchronous motor supported
Types of forced air cooling and water cooling optional

驱动器产品特点
Features of AC Motor Drives

采用美国TI公司新一代电机控制专用数字信号处理器(DSP), 主频可以达到150MHz。

TI latest motor-control specific digital signal processors (DSP) with clock frequency reaching up to 150Hz are adopted.

采用德国Infineon第四代IGBT模块, 结合其175°C最高结温特性, 运用创新型的PWM调制方式, 进一步降低了开关损耗, 使得驱动器在50°C环境温度下, 也无需降额使用。

As Infineon 4th generation IGBTs featured with maximum junction temperature up to 175°C are adopted, coupled with our innovative PWM modulation techniques, switch losses are remarkably reduced, with the result of no derating re-

支持异步电机和永磁同步电机驱动, 对异步电机和永磁同步电机的参数进行精准辨识。可以设定两组电机参数, 允许驱动器在两台不同的电机之间切换控制, 切换功能可以由功能码或多功能端子设定。

Asynchronous motors and permanent magnet synchronous motors control are supported, with accurate autotuning. Two independent motor profiles are programmed, and the switch over of the two motors' control can be realized by parameter setting or terminal input.

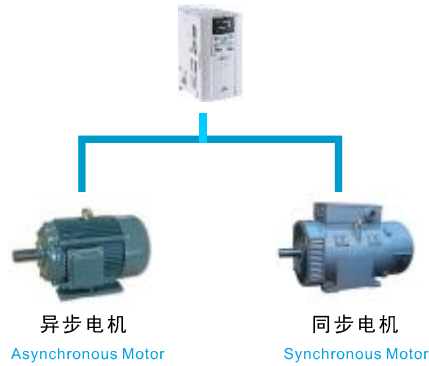

V/f控制模式下, 高精度的电流限定控制, 使得驱动器无论是快速加减速还是堵转, 都不会出现过电流报警, 可靠地保护驱动器; 矢量控制模式下, 高精度的转矩限定控制, 使得驱动器可以按用户工艺控制要求, 输出强劲的转矩或柔和的转矩, 可靠地保护机械设备。

In V/f control mode, accurate current limited control function makes sure of no over-current fault occurred no matter the drives are running at acceleration/deceleration, or rotor locked status, well protecting the drives. In vector control mode, accurate torque limited control pledges powerful or moderate torque complying with application requirements, protecting machinery well.

V/f分离控制模式下, 输出频率和输出电压可以分别设定, 适用于变频电源、力矩电机控制等应用场合。

In V/f separated control mode, output frequency and output voltage can be set respectively, fit for applications, such as variable frequency power sources, torque motors, etc.

控制模式 Control pattern	启动转矩 Starting torque	调速范围 Speed range	速度精度 Speed accuracy	转矩响应 Torque response
V/f控制 V/f control	0.5Hz 180%	1:100	±0.5%	
无PG矢量控制1 Speed-sensorless control 1	0.5Hz 180%	1:100	±0.2%	<10ms
无PG矢量控制2 Speed-sensorless control 2	0.25Hz 180%	1:200	±0.2%	<10ms
有PG矢量控制 Speed-sensor control	0Hz 200%	1:1000	±0.02%	<5ms



智能扩展口, 允许同时接入两块扩展卡, 满足用户实现行业特殊控制需求。

Intelligent expansion interfaces allow two expansion boards inserted at the same time, meeting demand of some specific applications.

编码器的安装位置不在电机的轴端时, 只要该轴与电机轴之间保持固定的减速比, 也能进行有PG矢量控制。

When the encoder is not mounted to the motor shaft directly, speed-sensor control can still be done as long as reduction ratio of detected shaft to motor shaft is correctly set.



驱动器产品特点
Features of AC Motor Drives

在有PG矢量控制方式下, 可进行零伺服、主轴定向(4个定向位置)、简易进位控制(8种进位量设置)、脉冲列位置控制等几种位置控制模式。

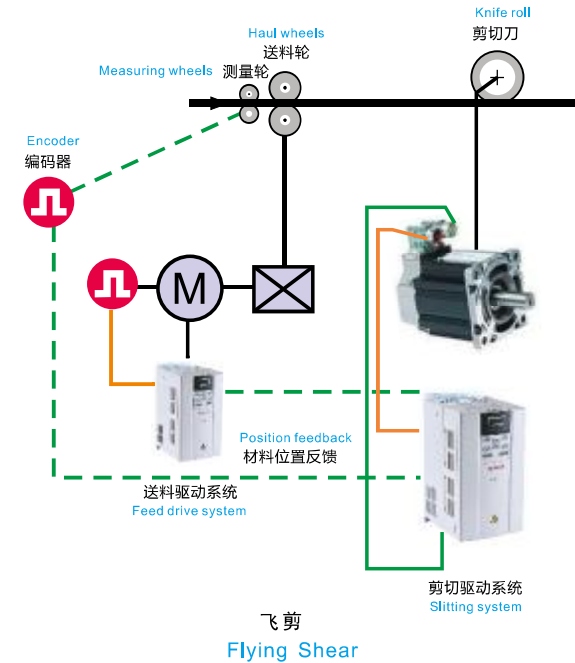

飞剪
Flying Shear

灵活的频率给定方式, 支持各种主、辅给定以及切换。

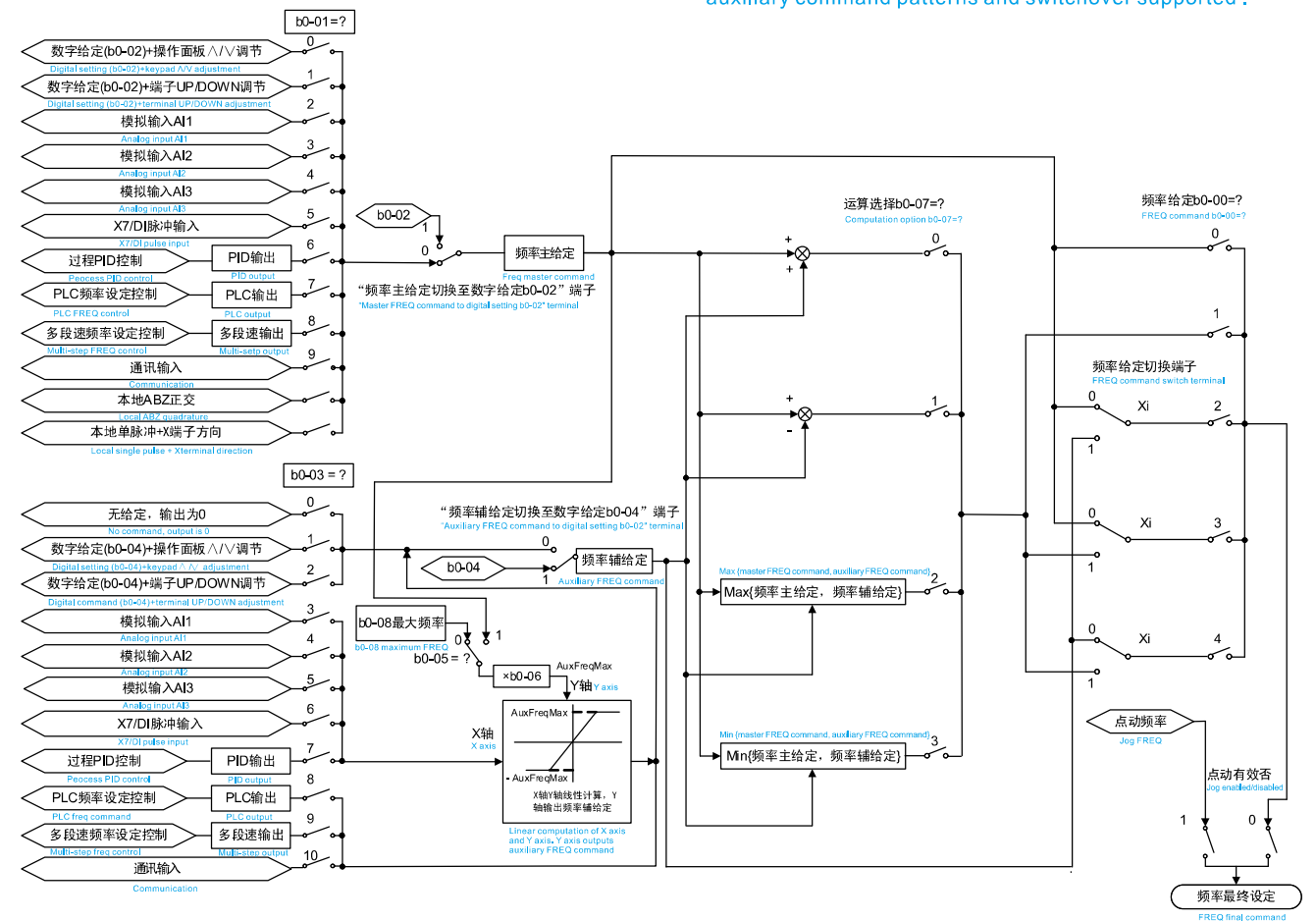

In speed-sensor control pattern, zero servo, motor spindle orientation (4 orientational positions programmable) control, simple feed control (8 feeds programmable), and pulse train position control can be performed.

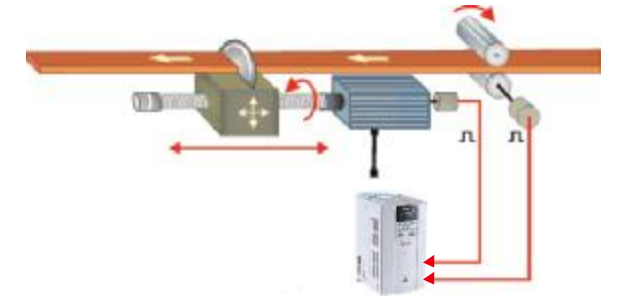

追剪
Tracking shear

Abundant frequency command sources. Various master, auxiliary command patterns and switchover supported.

具有多种加、减速曲线的选择，如：直线加减速、折线加减速、3种S曲线加减速。

Multi-Accel/Decel modes: linear, broken line, three kinds of S-curve.

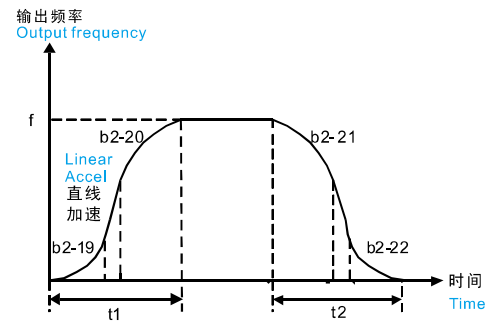
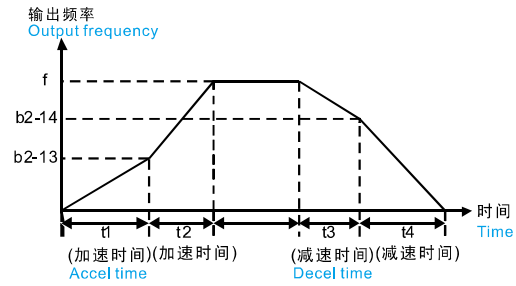

不依赖硬件的速度搜索起动功能，速度搜索准确、可靠，能对正在旋转中的电机进行无冲击的平滑起动。

Accurate and reliable flying start function assures smooth restart of rotary motors.

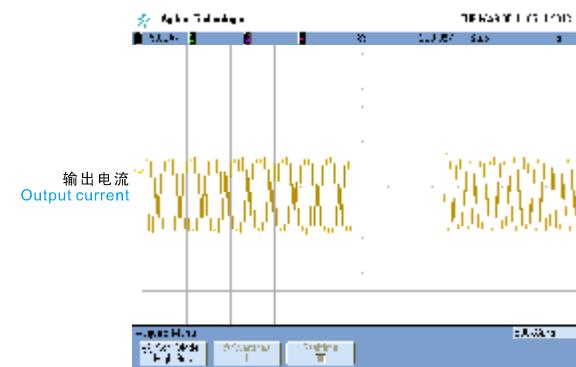

速度搜索起动
Flying start

可设置参数备份，方便用户备份参数、调试和参数恢复。

Parameters can be copied, and backed up.

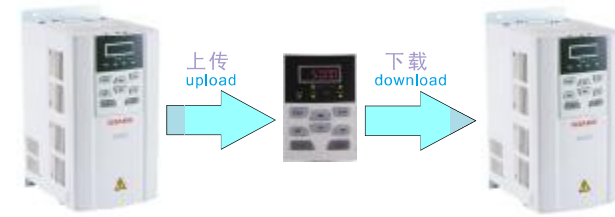

过程PID控制，具有丰富的给定和反馈方式，两组比例、积分和微分参数自由切换，可选择正作用和反作用特性。

Process PID control has abundant set and feedback sources, with two group parameters of proportional, integral, and differential programmable, positive and negative adjustment programmable.

支持直流电源的输入，方便用户组成共直流母线的方案。

DC power supply input supported. Common DC bus solution supported.

过压失速保护：大惯性负载减速运行过程中有短时再生制动时，通过对输出频率的瞬时调整，从而降低过压跳闸的机率，保证系统的连续可靠运行。

Over voltage stall protection: when driving a big inertia load, it is likely to produce regenerated energy in course of Decel. By adjusting the output frequent momentarily, the probability of over voltage trip will be reduced, pledging the system consecutive running.

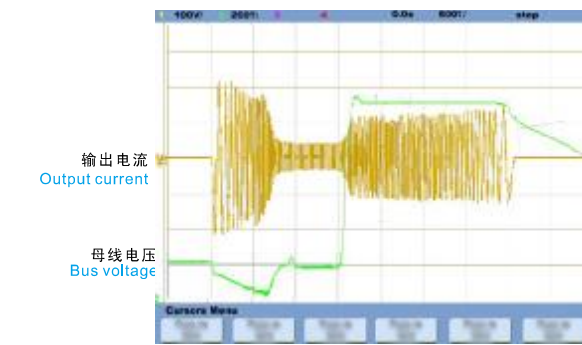

过压抑制
Overvoltage suppression

欠电压调节：在瞬时欠压或瞬时停电时，通过自动降低输出频率，维持直流母线电压的恒定，从而保证驱动器短时间内的连续运行，适合风机、离心泵等应用场合。

Undervoltage adjustment: when momentary undervoltage or momentary power loss occurs, dynamically reducing output frequency moderately will maintain the stability of DC bus voltage in short time, which usually applies to applications, like fans, centrifugal pumps, etc.

逐波限流功能，负载突变时，避免变频器频繁跳闸。

Cycle-by-cycle current limit function reduces trips at jumpy load.

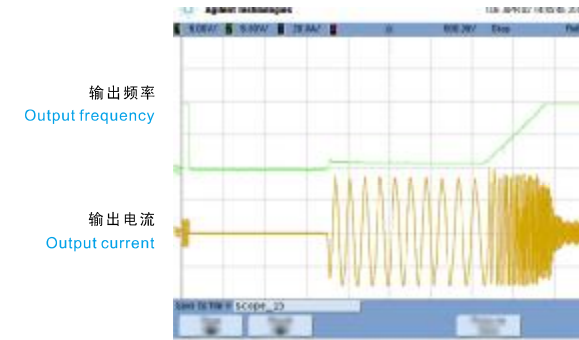

逐波限流
Cycle-by-cycle current limit

直流接触器断电保护功能，避免上电后因直流接触器触点异常断开而损坏上电缓冲电阻。

DC contactor power-off protection refrains from the damage of power-on buffer resistor resulted from contact abnormality of the DC contactor after applying power.

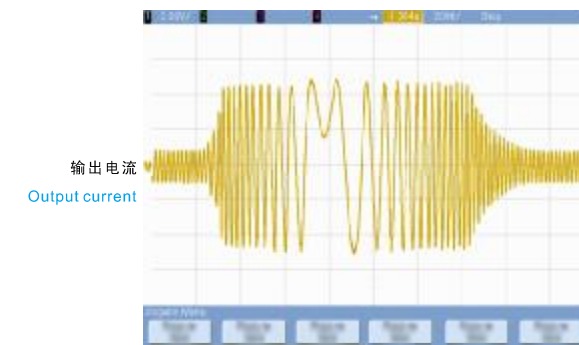

正反转切换(加减速时间0.1s)
Transition of forward/reverse run (Decel/Accel time: 0.1s)

所有单板有涂层防护，适应污染等级较高的应用场合。

Conformal coating well protects the drives against harsh environment.

采用计算机热仿真的方法，分析各监控点温度，通过风流速度场图和温度场图，估算出产品内部最高温升，为产品的合理结构提供了量化的依据。

Computer-aid thermal simulation techniques are adopted in course of structure design. Temperature rise of the highest temperature points are well estimated by adopting airflow and temperature field simulation, providing scientific criteria for optimal structure layout.

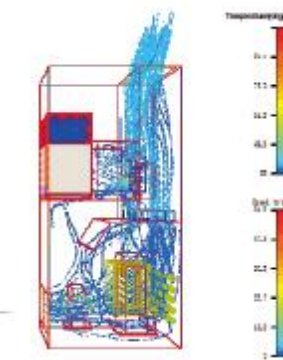

风流速度场图
Airflow field

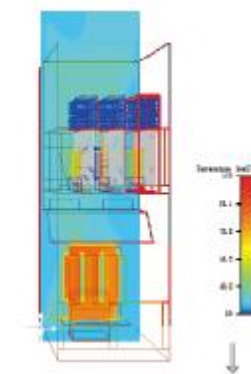

温度场图
TEMP field



丰富的选配件，满足客户多种使用需求。

Abundant accessories for different industrial requirements.

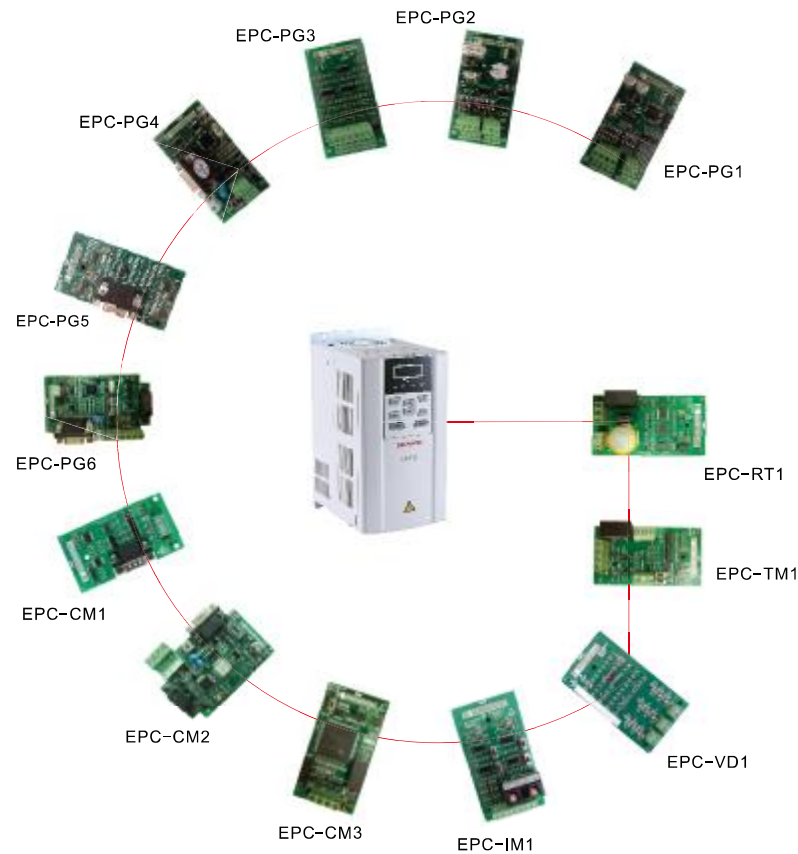

扩展卡 Expansion boards	功能描述 Specification
EPC-PG1	支持开路集电极、推挽型或差分型编码器输入, 电源12V或5V可选 支持A/B/Z信号的开路集电极分频输出 Support open collector, push-pull, and differential encoder signal input, with power supply 5V/12V programmable Support A/B/Z signal open collector frequency dividing output
EPC-PG2	支持开路集电极、推挽型或差分型编码器输入, 电源12V或5V可选 支持A/B/Z信号的差分分频输出, 即 A+/A-, B+/B-, Z+/Z-的分频输出 Support open collector, push-pull, and differential encoder signal input, with power supply 5V/12V programmable Support A/B/Z signal frequency dividing output, A+/A-, B+/B-, Z+/Z-
EPC-PG3	支持UVW编码器信号输入 Support UVW encoder signal input
EPC-PG4	支持旋转变压器信号输入 Support resolver signal input
EPC-PG5	支持正余弦编码器输入 Support SINCOS encoder input
EPC-PG6	支持旋转变压器信号输入, 同时支持两路模拟量输入扩展和CAN通讯扩展 Support resolver signal input, as well as two expanded analog inputs and CAN communication
EPC-CM1	支持232通讯扩展和CAN通讯扩展 Support expanded 232 communication and CAN communication
EPC-CM2	PROFIBUS-DP通讯适配卡 PROFIBUS-DP communication board
EPC-CM3	CANOPEN通讯适配卡 CANOPEN communication board
EPC-IM1	支持两路模拟量输入, 电压或电流输入可选; 电流输入范围: 0A~1A; 电压输入范围: 0V~24V Support two current/voltage programmable analog inputs Current input: 0A~1A. Voltage input: 0V~24V
EPC-VD1	支持输入电压、输出电压和母线电压检测 Support input voltage, output voltage and bus voltage detection
EPC-TM1	支持1路模拟量输入和1路数字输入, 1路模拟量输出和1组继电器输出 Support one analog input, one digital input, one analog output, and one relay output
EPC-RT1	支持实时时钟输入、1路模拟量输出、1组继电器输出 Support real-time clock input, one analog output, and one relay output

GK1000系列AFE能量回馈型变频器
GK1000 Series AFE Energy Feedback AC Motor Drives



特点
Features

- 有源功率因数校正, 电源端电流畸变率满足GB14549国标要求, 实现真正的绿色能源。
Active power factor correction ensures that current distortion at power supply end meets Chinese national standard GB14549, realizing green energy feedback.
- 无需要求电网相序, 自动运行并网, 四象限运行, 实时实现母线能量回馈; 特色的矢量控制算法, 实现高转换效率。
No requirement of power grid phase sequence, auto grid connection, four-quadrant operation, real-time bus energy feedback; advanced vector control algorithm ensures high efficiency of conversion.
- 具有自动调节母线电压功能, 保证所带负载转速和电流更加稳定, 即使出现电网电压瞬间波动或负载突变, 也能保证变频器不间断稳定运行, 减少负载发热, 延长负载寿命。
Auto bus voltage adjustment function makes sure of stable current and load speed. Even if momentary grid voltage fluctuation or abrupt load change occurs, consecutive and stable drive running are assured, with lower load temperature rise and longer load life.
- 便捷的无功调节, 净化电网。
Reactive power adjustment produces extremely low harmonics to power grid.
- 完美的模块化设计, 方便维护。
Modularized design makes maintenance convenient.

技术参数
Technical Data

功率范围 Power rating	30kW~630kW
额定电压 Rated voltage	3相380V/400V/415V/440V/460V/480V Triphase 380V/400V/415V/440V/460V/480V
电源频率 Power frequency	50Hz/60Hz, 波动给范围±5% 50Hz/60Hz, tolerance ±5%
功率因数 Power factor	0.95(容性, 感性)~1 0.95 (Advanced, Lagged) ~1
允许电压范围 Allowable voltage range	304V~506V
直流母线电压 DC bus voltage	450V~750V
输入电压容限 Input voltage allowance	电源电压可低40% 40% dropping at most
电流总谐波畸变率 (THD) Current THD	≤2.5% (额定功率下) ≤2.5% (at rated Amps)
过载能力 Overload capability	150% 1min; 180% 10s; 200% 0.5s, 间隔10min 150% 1min; 180% 10s; 200% 0.5s, every per 10min
防护等级 Protection grade	IP20

应用场合
Applications

- 传输链系统
Conveyor System
- 起重设备
Hoists & Cranes
- 直横剪纸机
Paper Shears
- 离心机
Centrifugal Machines
- 榨糖机
Sugar Mills
- 测功机
Eddy Current Dynamometers



ES100系列节能一体柜
ES100 Series Energy Saving Cabinet Drives



特点
Features

- ES100系列节能一体柜主要用于注塑机伺服节能，实现了压力闭环反馈控制，系统动态响应快，控制精度高。
ES100 Series Energy Saving Cabinet Drives are mainly used for injection molding machines, realizing pressure close-loop feedback control, with fast system response and high-precision control.
- 安装简单，节能效果好，维护成本低，性价比高。
Easier installation, well energy saving effect, lower maintenance cost, higher cost-performance ratio.
- 合理的结构设计，方便一体柜的日常保养和维护。
Considerate configuration makes maintenance easier
- 工频/变频切换功能避免因驱动器故障而影响生产。
Grid/Variable frequency switchable
- 通过智能压力闭环控制，控制注塑机电机在各个阶段的转速，确保油泵的出油量和注塑机的实际需求相一致，达到节能效果。
Intelligent pressure close-loop control function makes motor speed changed accordingly, to get pump oil output exactly meet molding machines need, realizing energy saving purpose.
- 快速的动态响应，提高生产效率：在流量和压力输出范围内，力矩快速建立和稳定输出，保证了加工工件的质量。
Fast response improves productivity: in the range of flow and pressure, a reliable output torque is established fast, ensuring high-quality products.
- 一流的输出转矩控制和电压控制技术，0s启动无跳闸。
Excellent output torque control and voltage control makes no trip even at 0s start.

应用场合
Applications

注塑机
Injection machines

压铸机
Die casting machines

空压机
Air compressor

中空吹塑机
Extrusion blow molding machines



新能源汽车电机控制器
New Energy Vehicle Motor Controllers



水冷
Water cooling



风冷
Forced air cooling

特点
Features

- 支持交流异步电机和永磁同步电机驱动。
Applicable to AC asynchronous motors and permanent magnet synchronous motors.
- 水冷和风冷两种冷却方式可选。
Types of water cooling and forced air cooling optional.
- 支持旋转变压器和光电编码器检测。
Resolvers and PE encoders signal input supported.
- 支持CAN总线控制、端子控制。
CAN bus communication control, and terminal control supported.
- 高功率密度，高效率，高防护等级。
High power density, high efficiency, and high IP grade.
- 完善的保护功能：输出短路、过流、过压、欠压、过热、过载、编码器断线等保护。
Overall protection: output short circuit, overcurrent, overvoltage, undervoltage, overtemperature, overload, encoder disconnected, etc.
- 输出力矩能力强，即使在弱磁区也有优异的力矩特性。
Strong capability of torque output. Unabated torque output characteristics even at field weakening.
- 防溜坡功能。
Anti-coasting function



控制特性
Technical Features

过载能力 Overload capability	150% 1min, 180% 10s, 200% 0.5s
调速范围 Speed range	1:1000
速度精度 Speed accuracy	±0.02%
速度波动 Speed ripple	±0.1%
转矩响应 Torque response	<5ms
转矩精度 Torque accuracy	±5%
起动转矩 Starting torque	0Hz 200%

应用场合
Applications

乘用车
Passenger Vehicles

电动车
EV

混合动力汽车
HEV





提 升 机 械

Hoists & Cranes

高起动转矩，响应快

无PG矢量控制0.25Hz达到180%输出转矩，<10ms的转矩响应时间；有PG矢量控制0Hz可提供200%输出转矩，<5ms的转矩响应时间；防止低速时因转矩不足，而导致负载滑落等事故。

双电机间切换

可分别设置两组电机参数，应用于1台变频器驱动行走和平移2个不同电机的场合。

抱闸控制功能

针对升降行业的抱闸逻辑控制及监控功能，更灵活地实现起重机平稳启停，有效防止物体的滑落。

完善的保护功能

全方位的报警及保护功能：满足行业安全标准要求。

Sufficient start torque, fast response

180% output torque at 0.25Hz, <10ms torque response time under speed-sensorless control pattern; 200% output torque at 0Hz, <5ms torque response time at speed-sensor control pattern. Slip accidents are prevented as the result of insufficient torque at low frequency.

Two motor profiles programmable

Two motor parameters are programmable respectively, fit for cases with two motors controlling two independent organs in a system.

Contracting brake control

Contracting brake control function specific for hoisting industry, assures smooth start/stop, and avoids hookslip accident.

Overall protection

Overall fault prompts, intelligent protections make the drives meet all relative safety requirements.

用途
Applications

塔式起重机
Tower Cranes

桥式起重机
Bridge Cranes

港机
Port Cranes

电动葫芦
Electric Hoists

施工升降机
Construction Hoists

卷扬机
Winches

电动绞车
Electric Winches

矿井提升机
Mine Hoists

特 点
Features

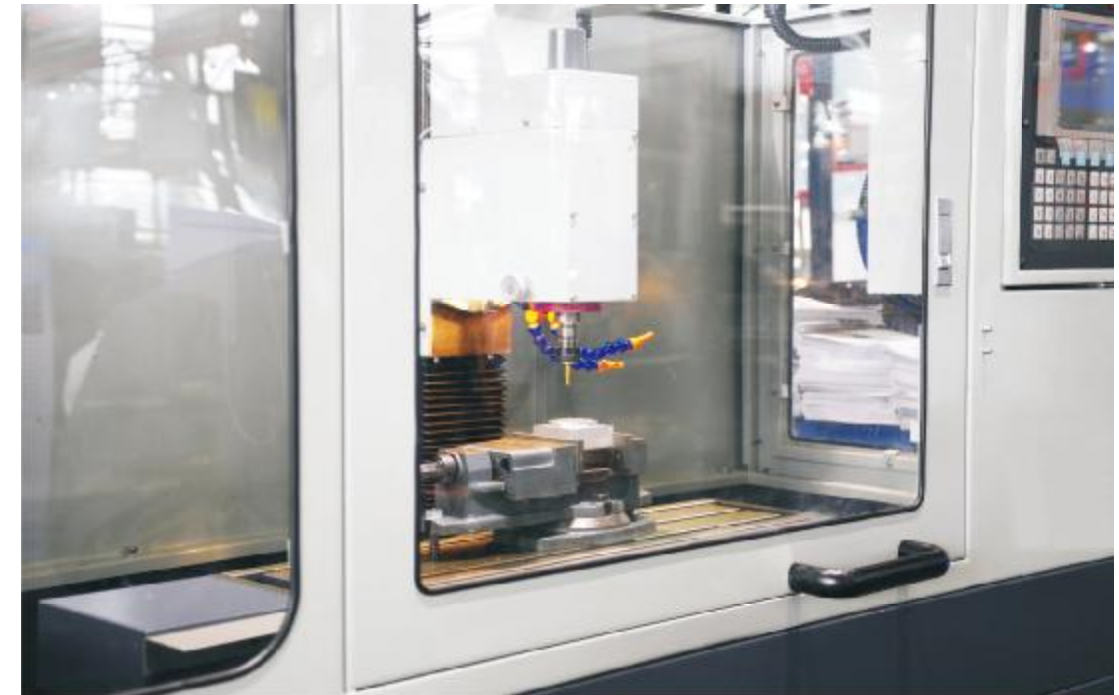

金 属 加 工 机 械

Metal Processing

低速高转矩

低速高转矩输出，满足客户加工要求。

多种位置控制模式

定位、定向、零伺服和脉冲列跟随等多种高精度位置控制方式，满足多种加工工艺要求。

高精度的稳速控制

独特的弱磁控制算法，保证高低速同样的转速精度。

完善的保护功能

全方位的报警及保护功能：满足行业安全标准要求。

丰富的接口设计和参数拷贝功能

方便方案设计和设备调试，简化配套客户的工作。

Adequate output torque at low frequency

Adequate output torque meets metal processing requirement at low speed .

Position control modes programmable

A variety of position control modes programmable: feed, orientation, zero servo, and pulse train.

High precision speed control

Field weakening control ensures the same speed stabilization no matter in high speed or low speed running.

Overall protection

Overall fault prompts, intelligent protections make the drives meet all relative safety requirements.

Abundant interfaces and parameter copy function

Ease commissioning and solution design.

用途
Applications

高速雕铣机
High-speed Engraving and Milling Machines

加工中心
Machining Centers

深孔钻
Deep-hole Drilling Machines

车床
Lathes

铣床
Milling Machines

磨床
Grinding Machines

特 点
Features



卷 绕 机 械

Winding & Unwinding

灵活的收放卷方式

多种卷径计算方式，对于中心收放卷场合，
能实现恒线速度、恒张力控制。

符合行业工艺要求的功能设计

摩擦补偿和惯量补偿功能，对于不同机械的
补偿调整，保证加减速时张力保持一致。

完美的成型控制

多种方式的张力锥度控制，保证收卷轴良好
的成型效果。

完善的保护功能

全方位的报警及保护功能：满足行业安全标
准要求。

丰富的接口设计和参数拷贝功能

方便方案设计和设备调试，简化配套客户
的工作。

Intelligent process control

Dynamical coil diameter calculation methods
realize stabilized linear speed, and constant
tension control to centre winding, unwinding
applications.

Specific functions

Friction compensation and inertia compensation
ensures constant tension in process of Accel/
Decel with different mechanical loads.

Molding control

Tension taper control guarantees impeccable
products.

Overall protection

Overall fault prompts, intelligent protections
make the drives meet all relative safety re-
quirements.

Abundant interfaces and parameter
copy function

Ease commissioning and solution design.

用途
Applications

- 印刷机械
Printing Machines
- 包装机械
Packing Machines
- 吹膜机
Plastic Puffing
Machines
- 拉丝机
Wire Drawing
Machines

特点
Features



油 泵 伺 服 驱 动

Oil Pump Servo Drives

稳速精度高、运行电流小

先进的矢量控制算法，确保运行时稳速精度高，
电流波动小，更有效地实现节能。

高精度、高响应PID控制

独特的高精度、高响应的PID控制模块，确保了
升压和泄压过程中压力响应快(<25ms)；保压
过程中压力稳定性强（压力波动<0.5kg）。

完美的硬件和结构设计

硬件的耐温点高，适用于注塑机高温作业；专
业的防护，有效避免灰尘、油污对驱动器的破
坏。

Precise speed, low current

Advanced vector control pledges precise speed,
small current fluctuation, realizing well energy
saving effect.

Precise, fast responded PID control

Precise, fast responded PID control pledges fast
pressure response (less than 25ms) in process
of pressure boosting and dropping, also stable
pressure in pressure holding.

Hardware and structure

Better heat-resistant hardware, higher IP grade.

用途
Applications

- 注塑机
Injection Molding
Machines
- 压铸机
Die Casting
Machines
- 鞋机
Shoemaking
Machines
- 中空吹塑机
Blow Moulding
Machines
- 工程机械
Construction
Machinery

特点
Features

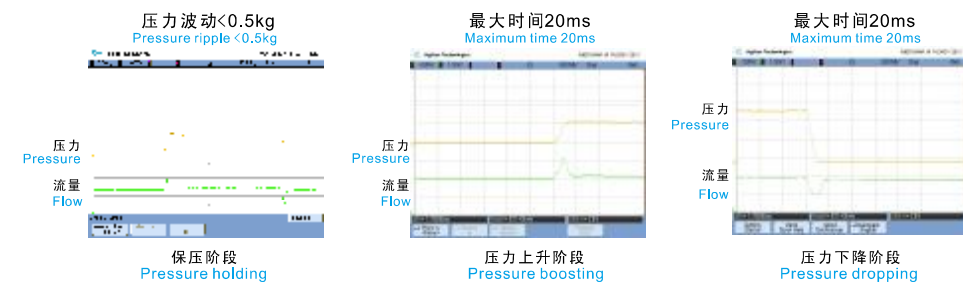

GK800产品型号命名规则
GK800 Model Explanation

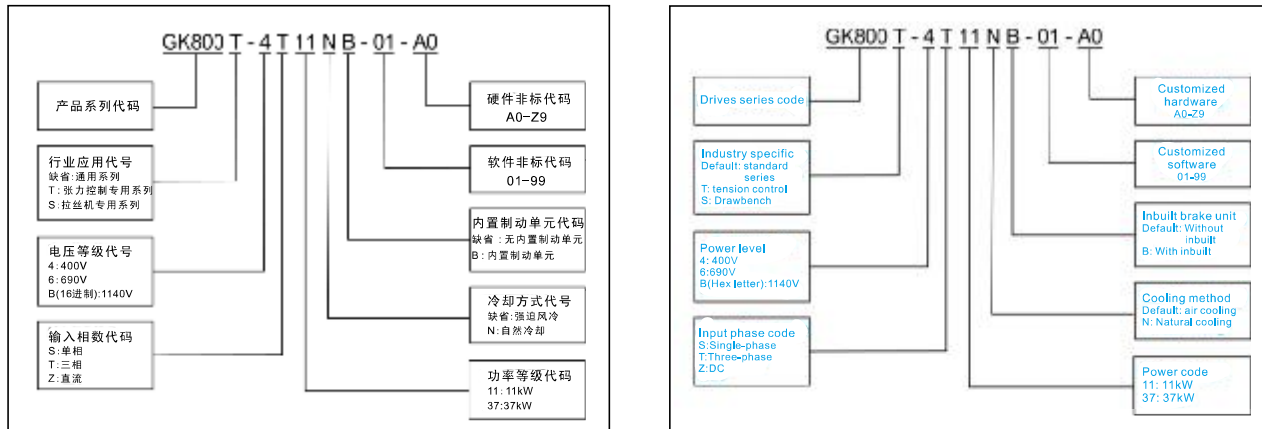

GK800产品型号及技术数据
Model Information of GK800 Series

产品型号 Model	功率等级(kW) Power rating	输出电流(A) Output current	输入电流(A) Input current	适配电机(kW) Applicable motor	制动单元 Brake unit	
GK800-4T1.5B	1.5	3.8	5.6	1.5	标准内置 Inbuilt	
GK800-4T2.2B	2.2	5.5	9.2	2.2		
GK800-4T3.7B	3.7	9	14.9	3.7		
GK800-4T5.5B	5.5	13	21.5	5.5		
GK800-4T7.5B	7.5	17	27.9	7.5		
GK800-4T11B	11	24	39	11		
GK800-4T15B	15	30	50.3	15		
GK800-4T18.5(B)*	18.5	39	60	18.5		
GK800-4T22(B)*	22	45	69.3	22		
GK800-4T30(B)*	30	60	86	30		
GK800-4T37(B)*	37	75	104	37	内置可选 Inbuilt optional	
GK800-4T45(B)*	45	91	124	45		
GK800-4T55(B)*	55	112	150	55		
GK800-4T75(B)*	75	150	201	75		
GK800-4T90	90	176	160**	90		外置 External optional
GK800-4T110	110	210	192**	110		
GK800-4T132	132	253	232**	132		
GK800-4T160	160	310	285**	160		
GK800-4T185	185	350	326**	185		
GK800-4T200	200	380	354**	200		
GK800-4T220	220	430	403**	220		
GK800-4T250	250	470	441**	250		
GK800-4T280	280	520	489**	280		
GK800-4T315	315	590	571**	315		
GK800-4T355	355	650	624**	355		
GK800-4T400	400	725	699**	400		
GK800-4T450	450	820	790**	450		
GK800-4T500	500	860	835**	500		
GK800-4T560	560	950	920**	560		
GK800-4T630	630	1100	1050**	630		

* 表示该功率等级变频器制动单元可选内置；以18.5为例：不带制动单元型号为GK800-4T18.5，带制动单元型号为GK800-4T18.5B，制动电阻需外配。
 * Means brake unit is optionally inbuilt. Take 18.5 for example: the model without brake unit is GK800-4T18.5, and the model with brake unit is GK800-4T18.5B. Brake resistor needs to be mounted externally.
 ** 配置直流电抗器后的输入电流。GK800-4T90及以上产品出厂配置外置直流电抗器，请务必将电抗器接入使用，否则会导致产品不能正常运行。
 ** Means the rated input current with the configuration of a DC reactor. The drive GK800-4T90 and above are provided with external-mounted DC reactor in shipment as default. Be sure to connect the DC reactors. Failure to comply may result in drive abnormal running.

GK800技术规格
Technical Features of GK800

功率输入 Power input	额定电压 Rated input voltage	3相380VAC/400VAC/415VAC/440VAC/460VAC/480VAC 3-phase 380VAC/400VAC/415VAC/440VAC/460VAC/480VAC			
	额定输入电流 Rated input current	参见GK800产品型号及技术数据表 See the table "Model information of GK800 series"			
功率输出 Power output	频率 Frequency	50Hz/60Hz，波动范围±5% 50Hz/60Hz, tolerance ±5%			
	允许电压范围 Allowable voltage range	电压持续波动±10%，短暂波动-15%~+10%，即323V~528V 电压不平衡率<3%，畸变率满足IEC61800-2要求 Voltage consecutive fluctuation ±10%, short fluctuation -15%~10%, i.e. 323V~528V Voltage out-of-balance rate <3%, THD meets standard IEC61800-2			
运行控制特性 Control characteristics	标准适用电机 (kW) Applicable motor	参见GK800产品型号及技术数据表 See the table "Model information of GK800 series"			
	额定电流 Rated current	参见GK800产品型号及技术数据表 See the table "Model information of GK800 series"			
基本功能 Basic functions	输出电压 Output voltage	3相: 0~额定输入电压, 误差小于±3% 3-phase: 0~rated input voltage, error less than ±3%			
	输出频率 Output frequency	0.00Hz~600Hz, 单位0.01Hz 0.00Hz~600Hz, Resolution 0.01Hz			
功率输入	过载能力 Over load capability	150% 1分钟; 180% 10秒; 200% 0.5秒, 间隔10分钟 150% 1min; 180% 10s; 200% 0.5s, once per 10 mins			
	控制方式 Control pattern	V/f控制 V/f control	无PG矢量控制1 Speed-sensorless control 1	无PG矢量控制2 Speed-sensorless control 2	有PG矢量控制 位置控制 Speed-sensor control Position control
功率输出	启动转矩 Starting torque	0.5Hz 180%	0.5Hz 180%	0.25Hz 180%	0Hz 200%
	调速范围 Speed range	1:100	1:100	1:200	1:1000
运行控制特性	调速精度 Speed accuracy	±0.5%	±0.2%	±0.2%	±0.02%
	速度波动 Speed ripple	—	±0.3%	±0.3%	±0.1%
基本功能	转矩控制 Torque control	无 No	有 Yes	有 Yes	有 Yes
	转矩精度 Torque accuracy	—	±7.5%	±7.5%	±5%
运行控制特性	转矩响应时间 Torque response	—	<10ms	<10ms	<5ms
	定位精度 Positioning accuracy	—	—	—	±1线脉冲 ±1 pulse
基本功能	启动频率 Start frequency	0.00Hz~600.00Hz			
	加速/减速时间 Accel/Decel time	0.00s~60000s			
运行控制特性	载波频率 Carrier frequency	0.7kHz~16kHz			
	频率设定方式 Frequency command modes	数字设定+操作面板Up/Down; 数字设定+端子Up/Down设定; 上位机通讯设定; 模拟设定; A11/A12/A13; 端子脉冲设定 Digital setting + Keypad Up/Down; Digital setting+terminal Up/Down; Communication setting; Analog setting: A11/A12/A13; Terminal pulse setting			
基本功能	启动方式 Start methods	从启动频率启动; 先直流制动再启动; 速度搜索启动 Start from starting frequency; DC injection braking at start; Flying start			
	停机方式 Stop methods	减速停机; 自由停车; 减速停机+直流制动 Ramp to stop; Coast to stop; DC injection braking at ramp stop			
运行控制特性	能耗制动能力 Dynamic brake capability	制动单元动作电压: 650V~750V; 使用时间0.0s~100.0s GK800-4T45及以下制动单元可内置 Braking unit triggered voltage: 650~750V; Service time: 0.0s~100.0s brake units of GK800-4T45 and below are optionally inbuilt			
	直流制动能力 DC braking capability	直流制动起始频率: 0.00Hz~600.00Hz; 直流制动电流: 恒转矩0.0%~100%; 直流制动时间: 0.0s~30.00s DC braking start frequency: 0.00Hz~600.00Hz; DC braking current: constant torque 0.0%~100.0%; DC braking time: 0.0s~30.00s			
基本功能	输入端子 Input terminals	七个数字输入端子, 其中一个可作高速脉冲输入。可兼容干节点、有源PNP、NPN输入方式; 三个模拟输入端子, 其中一个只能用作电压输入, 另两个电压电流可选 Seven digital input terminals, one of them can be used for pulse input. Compatible with dry contact, active PNP and NPN input. Three analog input terminals, one of them is voltage only, and the other two are voltage/current programmable			
	输出端子 Output terminals	一个高速脉冲输出端子(0kHz~50kHz的方波信号输出), 二个模拟量输出端子(电压/电流分别可选), 可实现设定频率、输出频率等物理量的输出; 一个开关量输出端子; 二组继电器输出端子 One high-speed pulse output (0kHz~50kHz square wave signal output), and two analog outputs (voltage/current programmable), can output signals such as command frequency, output frequency, etc. One digital output. Two relay outputs			
基本功能	编码器信号端子 Encode input terminal	兼容5V/12V电压等级; 兼容开路集电极、推挽和差分等不同类型的编码器信号输入 Compatible with 5V/12V power supply. Compatible with OC, push-pull, differential signal inputs and such			

特色功能 Characteristic functions	参数拷贝、参数备份、共直流母线、两组电机参数自由切换、灵活的功能码显隐性、各种主辅给定以及切换、可靠的速度搜索、多种加减速曲线选择、模拟量自动校正、抱闸控制、最多可支持16段速运行（两段速支持灵活的频率给定方式）、摆频控制运行、定长控制、计数、三组故障记录、过励磁制动、过压失速、欠电压调节、掉电再启动、频率跳跃、频率绑定、四段加减速时间自由切换、电机温度保护、灵活的风扇控制、过程PID控制、简易PLC控制、灵活的多功能键设置、下垂控制、异步机和同步机的参数辨识、弱磁控制、高精度的转矩限定、V/f分离控制、无PG转矩控制、有PG转矩控制、两路编码器信号输入（支持增量式、UVW混合式、旋转变压器等速度反馈形式）、灵活的减速比控制、零伺服、定向控制、简易进位控制、脉冲列位置控制		
	Parameter copy, parameter backup, common DC bus, two motors profiles programmable, flexible parameter display & hiding, various master & auxiliary command and switch over, reliable speed search started, a variety of Accel/Decel curves programmable, autocorrection of analog, contracting brake control, 16-step speed control programmable (2 steps support flexible frequency command), wobble frequency control, fixed length control, count function, three faults history, over excitation brake, overvoltage stall protection programmable, undervoltage stall protection programmable, restart upon power loss, skip frequency, frequency binding, four kinds of Accel/Decel time, motor thermal protection, flexible fan control, process PID control, simple PLC, multi-functional key programmable, droop control, asynchronous and synchronous motor parameters autotune, field weakening control, high-precision torque control, V/f separated control, torque control at speed-sensorless control, torque control at speed-sensor control, two encoders signal inputs (support incremental, UVW and resolver, etc.), flexible deceleration ratio control, zero servo, spindle orientation, simple feed control, pulse train position control		
保护功能 Protection	参见GK800说明书第七章故障诊断 Refer to "Chapter 7 Troubleshooting" in user manual of GK800 series		
环境 Environment	使用场所 Field	室内, 不受阳光直射, 无尘埃、腐蚀性气体、油雾、水蒸气、滴水或盐分等 Indoors, no direct sunlight, free from dust, corrosive gases, flammable gases, oil mist, water vapor, water drop, salt, etc.	
	海拔高度 Altitude	0m~2000m: 1000m以上降额使用, 每升高100m, 额定输出电流减少1% 0m~2000m: de-rate 1% for every 100m when above 1000 meters	
	环境温度 Temperature	-10℃~+50℃ 50℃~60℃之间降额使用, 每升高1℃, 额定输出电流减少1% -10℃~+50℃ 50℃~60℃: rated output current de-rates 1% for every 1°C above 50℃	
	湿度 Humidity	5%~95%, 不允许凝露 5%~95%, no condensation	
	振动 Vibration	小于5.9m/s ² (0.6g) Less than 5.9m/s ² (0.6g)	
存储温度 Storage temperature	-40℃~+70℃		
其它 Others	效率 Efficiency	额定功率时, 7.5kW及以下功率等级 ≥93%; 11kW~45kW功率等级 ≥95%; 55kW以上功率等级 ≥98% At rated Amps, 7.5kW and below: ≥93%; 11kW~45kW: ≥95%; 55kW and above: ≥98%	
	安装方式 Installation	壁挂式 Wall-mounted	
	防护等级 Protection grade	IP20	
	冷却方式 Cooling method	强迫风冷 Forced air cooling	

GK800产品外形和安装尺寸
External dimensions of GK800

产品型号 Model	外形和安装尺寸(mm) External dimensions							重量(kg) Weight (kg)
	W	H	D	W1	H1	H2	安装孔d Mounting hole dia.	
GK800-4T1.5B								
GK800-4T2.2B	120	245	169	80	233	220	5.5	2.6
GK800-4T3.7B								
GK800-4T5.5B								
GK800-4T7.5B	145	280	179	105	268	255	5.5	3.9
GK800-4T11B								
GK800-4T15B	190	365	187	120	353	335	6	5.0
GK800-4T18.5(B)								
GK800-4T22(B)	270	475	220	170	460	435	8	15.5
GK800-4T30(B)								
GK800-4T37(B)	320	568	239	220	544	515	10	24
GK800-4T45(B)								
GK800-4T55(B)	385	670	261	260	640	600	12	37
GK800-4T75(B)								
GK800-4T90	395	785	291	260	750	705	12	50
GK800-4T110								
GK800-4T132								
GK800-4T160	440	900	356	300	865	820	14	80
GK800-4T185								

产品型号 Model	外形和安装尺寸(mm) External dimensions							重量(kg) Weight (kg)
	W	H	D	W1	H1	H2	安装孔d Mounting hole dia.	
GK800-4T200								
GK800-4T220								
GK800-4T250	650	1040	406	400	1000	950	14	123
GK800-4T280								
GK800-4T315								
GK800-4T355								
GK800-4T400	815	1300	428	600	1252	1200	14	165
GK800-4T450								
GK800-4T500								
GK800-4T560	1100	2000	550					
GK800-4T630								

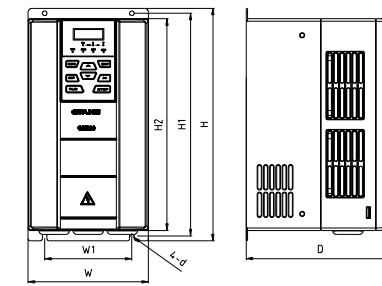

a) GK800-4T15B及以下

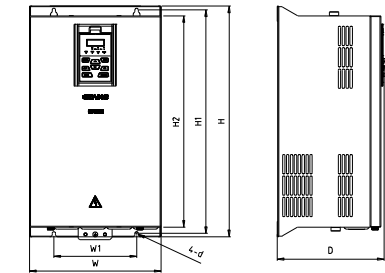

b) GK800-4T18.5~GK800-4T75

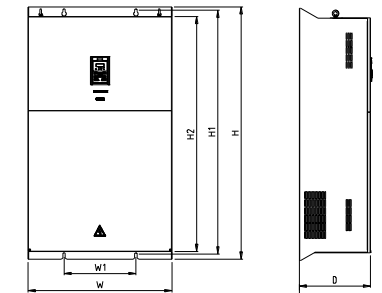

c) GK800-4T90~GK800-4T185

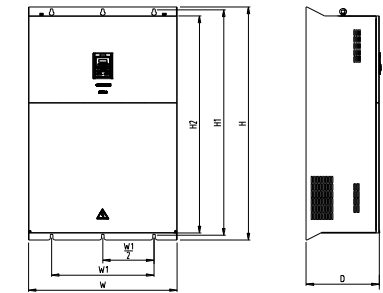

d) GK800-4T200~GK800-4T400

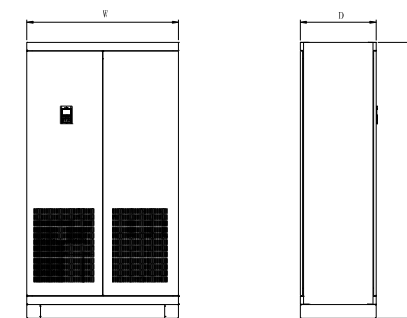

e) GK800-4T560~GK800-4T630



GK800控制端子功能说明
Specification of GK800 Control Terminals

类别 Category	端子符号 Terminal	端子名称 Terminal designation	技术规格 Specification
模拟量输入 Analog input	+10V	模拟量输入参考电压 Analog input reference voltage	10.3V±3% 最大输出电流25mA 即外接电位器时需大于400Ω的电位器 Maximum output current: 25mA Resistance of external potentiometer should be bigger than 400Ω
	GND	模拟地 Analog ground	内部与COM隔离 Isolated from COM interiorly
	AI1	模拟量输入1 Analog input 1	0mA~20mA: 输入阻抗500Ω, 最大输入电流25mA 0mA~20mA: input impedance 500Ω, maximum input current 25mA 0V~10V: 输入阻抗100kΩ, 最大输入电压12.5V 0V~10V: input impedance 100kΩ, maximum input voltage 12.5V 通过拨动开关S2实现0mA~20mA与0V~10V模拟量输入的切换, 出厂默认电压输入 0mA~20mA/0V~10V programmable by switch S2. Factory default: 0~10V
	AI2	模拟量输入2 Analog input 2	0mA~20mA: 输入阻抗500Ω, 最大输入电流25mA 0mA~20mA: input impedance 500Ω, maximum input current 25mA 0V~10V: 输入阻抗100kΩ, 最大输入电压12.5V 0V~10V: input impedance 100kΩ, maximum input voltage 12.5V 通过拨动开关S3实现0mA~20mA与0V~10V模拟量输入的切换, 出厂默认电压输入 Switch S3 on control board for jumping between 0mA~20mA and 0V~10V Factory default: 0V~10V 通过拨动开关S4实现直接检测电机温度模拟量输入 Realize motor thermal detection analog input by switch S4
	AI3	模拟量输入3 Analog input 3	-10V~10V: 输入阻抗25kΩ -10V~10V: input impedance 25kΩ 最大输入电压范围: -12.5V~+12.5V Range: -12.5V~+12.5V
模拟量输出 Analog output	AO1	模拟量输出1 Analog output 1	0mA~20mA: 阻抗要求200Ω~500Ω 0mA~20mA: impedance 200Ω~500Ω 0V~10V: 阻抗要求≥10kΩ 0V~10V: impedance ≥10kΩ 通过拨动开关S5实现0mA~20mA与0V~10V模拟量输出的切换, 出厂默认电压输出 Switch S5 on control board for jump between 0mA~20mA and 0V~10V output Factory default: 0V~10V
	AO2	模拟量输出2 Analog output 2	0mA~20mA: 阻抗要求200Ω~500Ω 0mA~20mA: impedance 200Ω~500Ω 0V~10V: 阻抗要求≥10kΩ 0V~10V: impedance ≥10kΩ 通过拨动开关S6实现0mA~20mA与0V~10V模拟量输出的切换, 出厂默认电压输出 Switch S6 on control board for jump between 0mA~20mA and 0V~10V output Factory default: 0V~10V
	GND	模拟地 Analog ground	内部与COM隔离 Isolated from COM interiorly
	+24V	+24V	24V±10%, 内部与GND隔离 24V±10%, Isolated from GND interiorly 最大负载200mA Maximum load 200mA
开关量输入 Digital input	PLC	开关量输入端子公共端 Digital input common terminal	开关量输入高低电平切换, 出厂时与+24V短接, 开关量输入低有效 Switch between high level and low level. Short-circuited with +24V at delivery, low value of digital input valid 外部电源输入 External power input
	COM	+24V地 +24V ground	内部与GND隔离 Isolated from GND interiorly 输入规格: 24VDC, 5mA Input: 24VDC, 5mA
	X1~X6	开关量输入端子1~6 Digital input terminals 1~6	频率范围: 0Hz~200Hz Frequency range: 0Hz~200Hz 电压范围: 10V~30V Voltage range: 10V~30V
	X7/DI	开关量输入/脉冲输入 Digital input/pulse input	开关量输入: 同X1~X6 Digital input: same as X1~X6 脉冲输入: 0.1Hz~50kHz; 电压范围: 10V~30V Pulse input: 0.1Hz~50kHz; Voltage range: 10~30V
开关量输出 Digital output	Y1	开路集电极输出 Open collector output	电压范围: 0V~24V Voltage range: 0V~24V 电流范围: 0mA~50mA Current range: 0mA~50mA
	Y2/DO	开路集电极输出/脉冲输出 Open collector out / Pulse out	开路集电极输出: 同Y1 Open collector output: same as Y1 脉冲输出: 0kHz~50kHz Pulse output: 0kHz~50kHz
继电器输出1 Relay out 1	RA/RB/RC	继电器输出 Control board relay output	RA-RB: 常闭; RA-RC: 常开 RA-RB: NC; RA-RC: NO 触点容量: 250VAC/3A, 30VDC/3A Contact capacity: 250VAC/3A, 30VDC/3A
	TA/TB/TC	继电器输出 Control board relay output	TA-TB: 常闭; TA-TC: 常开 TA-TB: NC; TA-TC: NO 触点容量: 250VAC/3A, 30VDC/3A Contact capacity: 250VAC/3A, 30VDC/3A

类别 Category	端子符号 Terminal	端子名称 Terminal designation	技术规格 Specification
编码器信号输入 Encoder signal input	VCC	编码器电源 Power supply of encoder	通过S7选择编码器5V/12V电源 Select 5V/12V by switch S7
	COM	编码器电源地 Encoder power ground	内部与GND隔离 Isolated from GND interiorly
	A+	A相输入正 Input A+	通过S7选择差分/OC输入模式; OC模式时, 该端子不接 Select differential/OC by switch S7. In OC mode, this terminal is unconnected
	A-	A相输入负 Input A-	通过S7选择差分/OC输入模式; OC模式时, 该端子直接与编码器A相信号相连 Select differential/OC by switch S7. In OC mode, this terminal is connected with encode A signal
	B+	B相输入正 Input B+	通过S7选择差分/OC输入模式; OC模式时, 该端子不接 Select differential/OC by switch S7. In OC mode, this terminal is unconnected
端子485接口 Terminal 485 Interface	485+	485差分信号正 Differential signal 485+	速率: 4800/9600/19200/38400/57600/115200bps Rate: 4800/9600/19200/38400/57600/115200bps 最长距离500m(采用标准网线) Maximum distance: 500m (use standard network cable)
	485-	485差分信号负 Differential signal 485-	
	GND	485通讯屏蔽接地 485 communication shielded ground	内部与COM隔离 Isolated from COM interiorly
操作面板485接口 Keypad 485 interface	CN4	操作面板485接口 Keypad 485 interface	连接操作面板时最长通讯距离15m Maximum communication distance is 15m when connected to keypad 采用标准网线 Use standard network cable

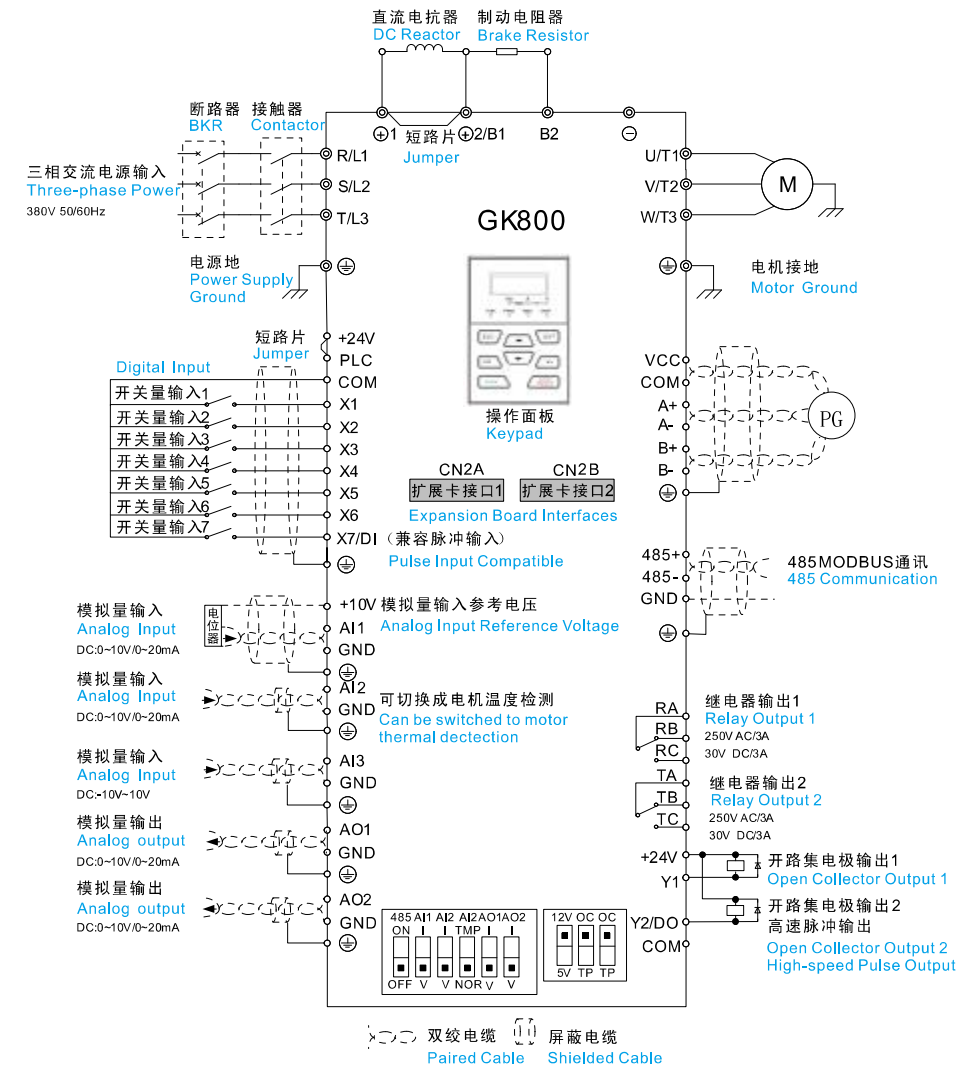

GK600产品型号命名规则
GK600 Model Explanation

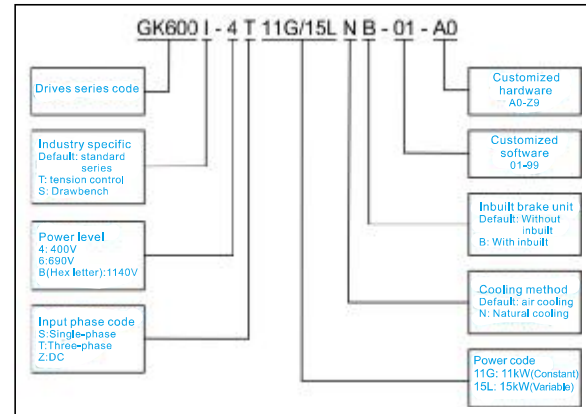
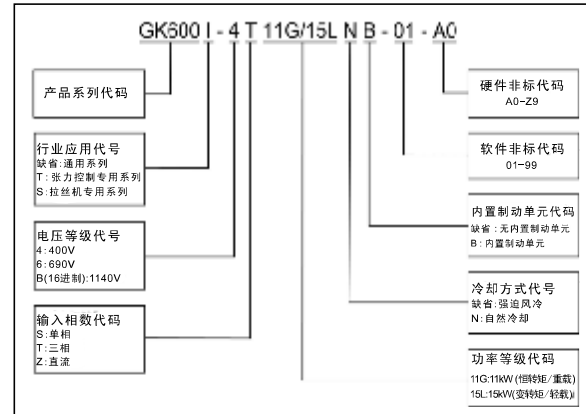

GK600产品型号及技术数据
Model Information of GK600 Series

产品型号 Model	功率等级(kW) Power rating	输出电流(A) Output current	输入电流(A) Input current	适配电机(kW) Applicable motor	制动单元 Brake unit
GK600-4T0.75G/1.5LB	0.75G	0.75	2.5	0.75	标准内置 Inbuilt
	1.5L	1.5	3.8	1.5	
GK600-4T1.5G/2.2LB	1.5G	1.5	3.8	1.5	
	2.2L	2.2	5.5	2.2	
GK600-4T2.2G/3.7LB	2.2G	2.2	5.5	2.2	
	3.7L	3.7	9	3.7	
GK600-4T3.7G/5.5LB	3.7G	3.7	9	3.7	
	5.5L	5.5	13	5.5	
GK600-4T5.5G/7.5LB	5.5G	5.5	13	5.5	
	7.5L	7.5	17	7.5	
GK600-4T7.5G/11LB	7.5G	7.5	17	7.5	
	11L	11	24	11	
GK600-4T11G/15LB	11G	11	24	11	
	15L	15	30	15	
GK600-4T15G/18.5LB	15G	15	30	15	
	18.5L	18.5	39	18.5	
GK600-4T18.5G/22L(B)*	18.5G	18.5	39	18.5	内置可选 Inbuilt optional
	22L	22	45	22	
GK600-4T22G/30L(B)*	22G	22	45	22	
	30L	30	60	30	
GK600-4T30G/37L(B)*	30G	30	60	30	
	37L	37	75	37	
GK600-4T37G/45L(B)*	37G	37	75	37	
	45L	45	91	45	
GK600-4T45G/55L(B)*	45G	45	91	45	
	55L	55	112	55	
GK600-4T55G/75L(B)*	55G	55	112	55	
	75L	75	150	75	
GK600-4T75G/90L(B)*	75G	75	150	75	
	90L	90	176	90	
GK600-4T90G/110L	90G	90	176	90	
	110L	110	210	110	
GK600-4T110G/132L	110G	110	210	110	外置 External optional
	132L	132	253	132	
GK600-4T132G/160L	132G	132	253	132	
	160L	160	310	160	
GK600-4T160G/185L	160G	160	310	160	
	185L	185	350	185	

产品型号 Model	功率等级(kW) Power rating	输出电流(A) Output current	输入电流(A) Input current	适配电机(kW) Applicable motor	制动单元 Brake unit
GK600-4T185G/200L	185G	185	350	185	外置 External optional
	200L	200	380	200	
GK600-4T200G/220L	200G	200	380	200	
	220L	220	430	220	
GK600-4T220G/250L	220G	220	430	220	
	250L	250	470	250	
GK600-4T250G/280L	250G	250	470	250	
	280L	280	520	280	
GK600-4T280G/315L	280G	280	520	280	
	315L	315	590	315	
GK600-4T315G/355L	315G	315	590	315	
	355L	355	650	355	
GK600-4T355G/400L	355G	355	650	355	
	400L	400	725	400	
GK600-4T400G/450L	400G	400	725	400	
	450L	450	820	450	
GK600-4T450G/500L	450G	450	820	450	
	500L	500	860	500	
GK600-4T500G	500G	500	860	500	
	560L	560	950	560	
GK600-4T560G	560G	560	950	560	
	630L	630	1100	630	
GK600-4T630G	630G	630	1100	630	
	710L	710			

* 表示该功率等级变频器制动单元可选内置；以18.5G/22L为例：不带制动单元型号为GK600-4T18.5G/22L，带制动单元型号为GK600-4T18.5G/22LB，制动电阻需外配
 * Means brake unit is optionally inbuilt. Take 18.5G/22L for example: the model without brake unit is GK600-4T18.5G/22L, and the model with brake unit is GK600-4T18.5G/22LB. Brake resistor needs to be mounted externally
 ** 配置直流电抗器后的输入电流。GK600-4T90G/110L及以上产品出厂配置外置直流电抗器。请务必将电抗器接入使用，否则会导致产品不能正常运行。
 ** Means the rated input current with the configuration of a DC reactor. The drive GK600-4T90G/110L and above are provided with external-mounted DC reactor in shipment as default. Be sure to connect the DC reactors. Failure to comply may result in drive abnormal running.

GK600技术规格
Technical Features of GK600

功率输入 Power input	额定电压 Rated input voltage	3相380VAC/400VAC/415VAC/440VAC/460VAC/480VAC 3-phase 380VAC/400VAC/415VAC/440VAC/460VAC/480VAC		
	额定输入电流 Rated input current	参见GK600产品型号及技术数据表 See the table "Model information of GK600 series"		
功率输出 Power output	频率 Frequency	50Hz/60Hz，波动范围±5% 50Hz/60Hz, tolerance ±5%		
	允许电压范围 Allowable voltage range	电压持续波动±10%，短暂波动-15%~+10%，即323V~528V 电压失平衡率<3%，畸变率满足IEC61800-2要求 Voltage consecutive fluctuation ±10%, short fluctuation -15%~10%, i.e. 323V~528V Voltage out-of-balance rate <3%, THD meets standard IEC61800-2		
运行控制特性 Control characteristics	标准适用电机(kW) Applicable motor	参见GK600产品型号及技术数据表 See the table "Model information of GK600 series"		
	额定电流 Rated current	参见GK600产品型号及技术数据表 See the table "Model information of GK600 series"		
运行控制特性 Control characteristics	输出电压 Output voltage	3相: 0~额定输入电压, 误差小于±3% 3-phase: 0~rated input voltage, error less than ±3%		
	输出频率 Output frequency	0.00Hz~600Hz, 单位0.01Hz 0.00Hz~600Hz, Resolution 0.01Hz		
运行控制特性 Control characteristics	过载能力 Over load capability	150% 1分钟; 180% 10秒; 200% 0.5秒, 间隔10分钟 150% 1min; 180% 10s; 200% 0.5s, once per 10 mins		
	控制方式 Control pattern	V/f控制 V/f control	无PG矢量控制1 Speed-sensorless control 1	无PG矢量控制2 Speed-sensorless control 2
运行控制特性 Control characteristics	启动转矩 Start torque	0.5Hz 180%	0.5Hz 180%	0.25Hz 180%
	调速范围 Speed range	1:100	1:100	1:200
运行控制特性 Control characteristics	稳速精度 Speed accuracy	±0.5%	±0.2%	±0.2%
	速度波动 Speed ripple	—	±0.3%	±0.3%
运行控制特性 Control characteristics	转矩响应时间 Torque response	—	<10ms	<10ms
	启动频率 Start frequency	0.00Hz~600.00Hz		
运行控制特性 Control characteristics	加速时间 Accel/Decel time	0.00s~60000s		
	载波频率 Carrier frequency	0.7kHz~16kHz		

基本功能 Basic functions	频率设定方式 Frequency command modes	数字设定+操作面板Up/Down; 数字设定+端子Up/Down设定; 上位机通讯设定; 模拟设定: AI1/AI2; 端子脉冲设定 Digital setting +Keypad Up/Down; Digital setting+terminal Up/Down; Communication setting; Analog setting: AI1/AI2; Terminal pulse setting
	启动方式 Start methods	从启动频率启动; 先直流制动再启动; 速度搜索启动 Start from starting frequency; DC injection braking at start; Flying start
	停机方式 Stop methods	减速停机; 自由停车; 减速停机+直流制动 Ramp to stop; Coast to stop; DC injection braking at ramp stop
	能耗制动能力 Dynamic brake capability	制动单元动作电压: 650V~750V; 使用时间0.0s~100.0s GK600-4T45G/55L及以下制动单元可内置 Braking unit triggered voltage:650~750V; Service time: 0.0s~100.0s brake units of GK600-4T45G/55L and below are optionally inbuilt
	直流制动能力 DC braking capability	直流制动起始频率: 0.00Hz~600.00Hz; 直流制动电流: 恒转矩0.0~100%; 直流制动时间: 0.0s~30.00s DC braking start frequency: 0.00Hz~600.00Hz; DC braking current: constant torque 0.0~100.0%; DC braking time: 0.0s~30.00s
	输入端子 Input terminals	六个数字输入端子, 其中一个可作高速脉冲输入, 可兼容干节点、有源PNP、NPN输入方式; 两个模拟输入端子, 其中一个只能用作电压输入, 另一个电压电流可选 Six digital input terminals, one of them can be used for pulse input, compatible with dry contact, active PNP and NPN input. Two analog input terminals, one of them is voltage only, and the other is voltage/current programmable
输出端子 Output terminals	一个高速脉冲输出端子(0kHz~50kHz的方波信号输出), 一个模拟量输出端子(电压/电流分别可选), 可实现设定频率、输出频率等物理量的输出; 一个开关量输出端子: 一组继电器输出端子 One high-speed pulse output (0kHz~50kHz square wave signal output), one analog output (voltage/current programmable), can output signals such as command frequency, output frequency, etc. One digital output; one relay output	
特色功能 Characteristic functions	参数拷贝、参数备份、共直流母线、两组电机参数自由切换、灵活的功能码显隐、各种主辅给定以及切换、可靠的速度搜索、多种加减速曲线选择、模拟量自动校正、抱闸控制、最多可支持16段速运行(两段速支持灵活的频率给定方式)、摆频控制运行、定长控制、计数、三组故障记录、过励磁制动、过压失速、欠电压调节、掉电再启动、频率跳跃、频率绑定、四段加减速时间自由切换、电机温度保护、灵活的风扇控制、过程PID控制、简易PLC控制、灵活的多功能键设置、下垂控制、异步机和同步机的参数辨识、弱磁控制、高精度的转矩限定、V/f分离控制 Parameter copy, parameter backup, common DC bus, two motors profiles programmable, flexible parameter display & hiding, various master & auxiliary command and switch over, reliable speed search started, a variety of Accel/Decel curves programmable, autocorrection of analog, contracting brake control, 16-step speed control programmable (2 steps support flexible frequency command), wobble frequency control, fixed length control, count function, three faults history, over excitation brake, overvoltage stall protection programmable, undervoltage stall protection programmable, restart upon power loss, skip frequency, frequency binding, four kinds of Accel/Decel time, motor thermal protection, flexible fan control, process PID control, simple PLC, multi-functional key programmable, droop control, asynchronous and synchronous motor parameters autotune, field weakening control, high-precision torque control, V/f separated control	
保护功能 Protection	参见GK600说明书第七章故障诊断 Refer to 'Chapter 7 Troubleshooting' in user manual of GK600 series	
环境 Environment	使用场所 Field	室内, 不受阳光直射, 无尘埃、腐蚀性气体、油雾、水蒸气、滴水或盐分等 Indoors, no direct sunlight, free from dust, corrosive gases, flammable gases, oil mist, water vapor, water drop, salt, etc.
	海拔高度 Altitude	0m~2000m: 1000m以上降额使用, 每升高100m, 额定输出电流减少1% 0m~2000m: de-rate 1% for every 100m when above 1000 meters
	环境温度 Temperature	-10℃~+50℃ 50℃~60℃之间降额使用, 每升高1℃, 额定输出电流减少1% -10℃~+50℃ 50℃~60℃: rated output current de-rates 1% for every 1℃ above 50℃
	湿度 Humidity	5%~95%, 不允许凝露 5%~95%, no condensation
	振动 Vibration	小于5.9m/s ² (0.6g) Less than 5.9m/s ² (0.6g)
存储温度 Storage temperature	-40℃~+70℃	
其它 Others	效率 Efficiency	额定功率时, 7.5kW及以下功率等级≥93%; 11kW~45kW功率等级≥95%; 55kW以上功率等级≥98% At rated Amps, 7.5kW and below: ≥93%; 11kW~45kW: ≥95% 55kW and above: ≥98%
	安装方式 Installation	壁挂式 Wall-mounted
	防护等级 Protection grade	IP20
	冷却方式 Cooling method	强迫风冷 Forced air cooling

GK600产品外形和安装尺寸
External Dimensions of GK600

产品型号 Model	外形和安装尺寸(mm) External dimensions							重量(kg) Weight (kg)
	W	H	D	W1	H1	H2	安装孔d Mounting hole dia.	
GK600-4T0.75G/1.5LB	93	190	152	70	180	172	4.5	1.8
GK600-4T1.5G/2.2LB	120	245	169	80	233	220	5.5	2.6
GK600-4T2.2G/3.7LB	145	280	179	105	268	255	5.5	3.9
GK600-4T3.7G/5.5LB								
GK600-4T5.5G/7.5LB								
GK600-4T7.5G/11LB								

产品型号 Model	外形和安装尺寸(mm) External dimensions							重量(kg) Weight (kg)
	W	H	D	W1	H1	H2	安装孔d Mounting hole dia.	
GK600-4T11G/15LB	190	365	187	120	353	335	6	5.0
GK600-4T15G/18.5LB								
GK600-4T18.5G/22L(B)	270	475	220	170	460	435	8	15.5
GK600-4T22G/30LB(B)								
GK600-4T30G/37LB(B)								
GK600-4T37G/45LB(B)	320	568	239	220	544	515	10	24
GK600-4T45G/55LB(B)								
GK600-4T55G/75L(B)	385	670	261	260	640	600	12	37
GK600-4T75G/90L(B)								
GK600-4T90G/110L	395	785	291	260	750	705	12	50
GK600-4T110G/132L								
GK600-4T132G/160L								
GK600-4T160G/185L	440	900	356	300	865	820	14	80
GK600-4T185G/200L								
GK600-4T200G/220L								
GK600-4T220G/250L	650	1040	406	400	1000	950	14	123
GK600-4T250G/280L								
GK600-4T280G/315L								
GK600-4T315G/355L								
GK600-4T355G/400L								
GK600-4T400G/450L	815	1300	428	600	1252	1200	14	165
GK600-4T450G/500L								
GK600-4T500G								
GK600-4T560G	1100	2000	550					
GK600-4T630G								

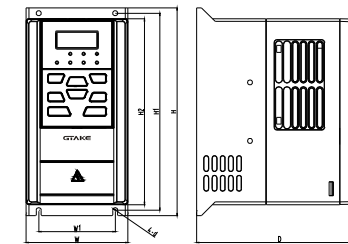

a) GK600-4T1.5G/2.2LB及以下

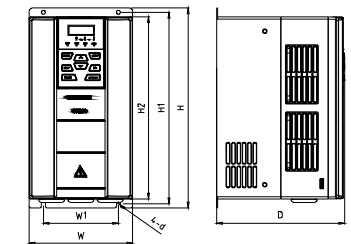

b) GK600-4T2.2G/3.7LB~GK600-4T15G/18.5LB

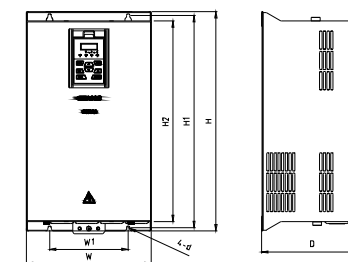

c) GK600-4T18.5G/22LB~GK600-4T75G/90L

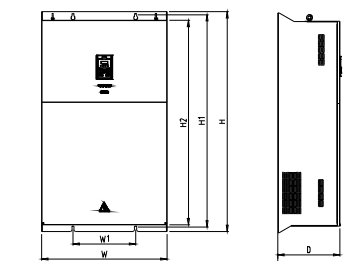

d) GK600-4T90G/110L~GK600-4T185G/200L

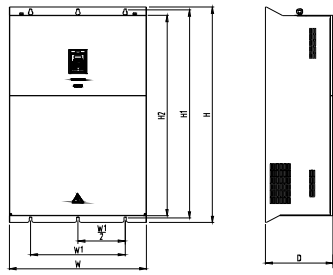

e) GK600-4T200G/220L~GK600-4T500G/560L

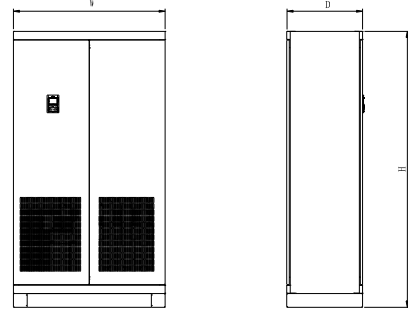

f) GK600-4T560G/630L~GK600-4T630G/710L

GK600控制端子功能说明

Specification of GK600 Control Terminals

类别 Category	端子符号 Terminal	端子名称 Terminal designation	技术规格 Specification
模拟量输入 Analog input	+10V	模拟量输入参考电压 Analog input reference voltage	10.3V±3% 最大输出电流25mA 即外接电位器时需大于400Ω的电位器 Maximum output current: 25mA Resistance of external potentiometer should be bigger than 400Ω
	GND	模拟地 Analog ground	内部与COM隔离 Isolated from COM interiorly 0mA~20mA: 输入阻抗500Ω, 最大输入电流25mA 0mA~20mA: input impedance 500Ω, maximum input current 25mA
	AI1	模拟量输入1 Analog input 1	0V~10V: 输入阻抗100kΩ, 最大输入电压12.5V 0V~10V: input impedance 100kΩ, maximum input voltage 12.5V 通过拨动开关S2实现0mA~20mA与0V~10V模拟量输入的切换, 出厂默认电压输入 0mA~20mA/0V~10V programmable by switch S2. Factory default: 0~10V
	AI2	模拟量输入2 Analog input 2	-10V~10V: 输入阻抗25kΩ -10V~10V: input impedance 25kΩ 最大输入电压范围: -12.5V~+12.5V Range: -12.5V~+12.5V
模拟量输出 Analog output	AO1	模拟量输出1 Analog output 1	0mA~20mA: 阻抗要求200Ω~500Ω 0mA~20mA: impedance 200Ω~500Ω 0V~10V: 阻抗要求≥10kΩ 0V~10V: impedance ≥10kΩ 通过拨动开关S3实现0mA~20mA与0V~10V模拟量输出的切换, 出厂默认电压输出 Switch S3 on control board for jump between 0mA~20mA and 0V~10V output Factory default: 0V~10V
	GND	模拟地 Analog ground	内部与COM隔离 Isolated from COM interiorly
开关量输入 Digital input	+24V	+24V	24V±10%, 内部与GND隔离 24V±10%, Isolated from GND interiorly 最大负载200mA Maximum load 200mA
	PLC	开关量输入端子公共端 Digital input common terminal	开关量输入高低电平切换。出厂时与+24V短接, 开关量输入低有效 Switch between high level and low level. Short-circuited with +24V at delivery, low value of digital input valid 外部电源输入 External power input
	COM	+24V地 +24V ground	内部与GND隔离 Isolated from GND interiorly 输入规格: 24VDC, 5mA Input: 24VDC, 5mA
	X1~X5	开关量输入端子1~5 Digital input terminals 1~5	频率范围: 0Hz~200Hz Frequency range: 0Hz~200Hz 电压范围: 10V~30V Voltage range: 10V~30V
	X6/DI	开关量输入/脉冲输入 Digital input/pulse input	开关量输入: 同X1~X5 Digital input: same as X1~X5 脉冲输入: 0.1Hz~50kHz; 电压范围: 10V~30V Pulse input: 0.1Hz~50kHz; Voltage range: 10V~30V

类别 Category	端子符号 Terminal	端子名称 Terminal designation	技术规格 Specification
开关量输出 Digital output	Y1	开路集电极输出 Open collector output	电压范围: 0V~24V Voltage range: 0V~24V 电流范围: 0mA~50mA Current range: 0mA~50mA
	Y2/DO	开路集电极输出/脉冲输出 Open collector out / Pulse out	开路集电极输出: 同Y1 Open collector output: same as Y1 脉冲输出: 0kHz~50kHz Pulse output: 0kHz~50kHz
继电器输出 Relay output	RA/RB/RC	继电器输出 Control board relay output	RA-RB: 常闭; RA-RC: 常开 RA-RB: NC; RA-RC: NO 触点容量: 250VAC/3A, 30VDC/3A Contact capacity: 250VAC/3A, 30VDC/3A
端子485接口 Terminal 485 Interface	485+	485差分信号正 Differential signal 485+	速率: 4800/9600/19200/38400/57600/115200bps Rate: 4800/9600/19200/38400/57600/115200bps
	485-	485差分信号负 Differential signal 485-	最长距离500m(采用标准网线) Maximum distance: 500m (use standard network cable)
	GND	485通讯屏蔽接地 485 communication shielded ground	内部与COM隔离 Isolated from COM interiorly
操作面板 485接口 Keypad 485 interface	CN4	操作面板485接口 Keypad 485 interface	连接操作面板时最长通讯距离15m Maximum communication distance is 15m when connected to keypad 采用标准网线 Use standard network cable

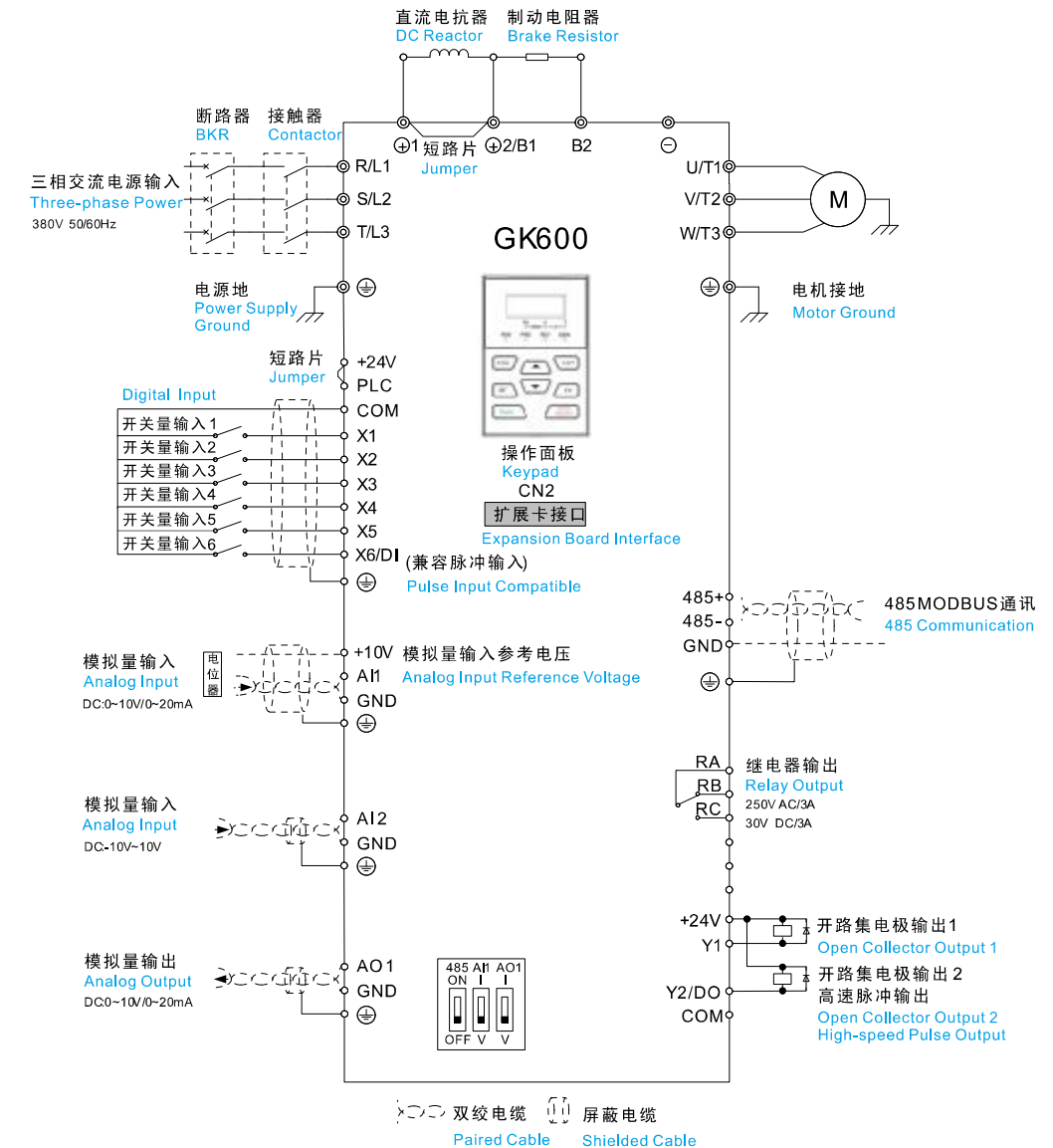

GK500产品型号命名规则
GK500 Model Explanation

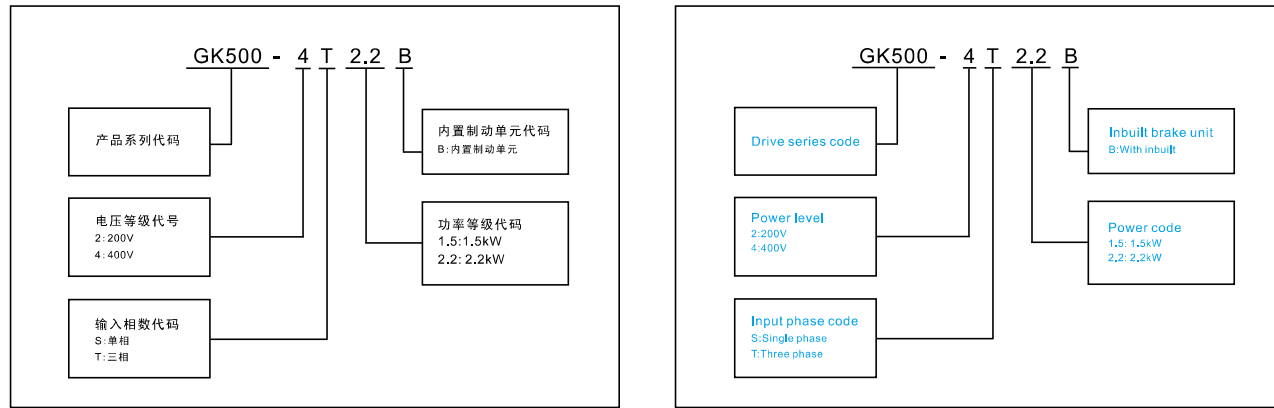

GK500产品型号及技术数据
Model Information of GK500 Series

电压等级 Voltage	产品型号 Model	功率等级 (kW) Power rating	输出电流 (A) Output current	输入电流 (A) Input current	适配电机 (kW) Applicable motor	制动单元 Brake unit
200V	GK500-2T0.4B	0.4	2.6	5.5	0.4	标准内置 Inbuilt
	GK500-2T0.75B	0.75	4.5	9.2	0.75	
	GK500-2T1.5B	1.5	7.5	14.5	1.5	
	GK500-2T2.2B	2.2	9.6	23	2.2	
400V	GK500-4T0.75B	0.75	2.5	3.4	0.75	
	GK500-4T1.5B	1.5	3.8	5.6	1.5	
	GK500-4T2.2B	2.2	5.5	8.1	2.2	
	GK500-4T3.7B	3.7	9	13.5	3.7	

GK500技术规格
Technical Features of GK500

功率输入 Power input	额定电压 Rated input voltage	3相380VAC~480VAC; 3相200VAC~240VAC; 单相200VAC~260VAC 3-phase 380VAC~480VAC; 3-phase 200VAC~240VAC; single phase 200VAC~260VAC
	额定输入电流 Rated input current	参见GK500产品型号及技术数据表 See the table "Model information of GK500 series"
	频率 Frequency	50Hz/60Hz; 波动范围±5% 50Hz/60Hz, tolerance ±5%
允许电压范围 Allowable voltage range	电压持续波动±10%, 短暂波动-15%~+10% 电压失平衡率<3%, 畸变率满足IEC61800-2要求 Voltage consecutive fluctuation ±10%, short fluctuation -15%~+10% Voltage out-of-balance rate <3%, THD meets standard IEC61800-2	
功率输出 Power output	标准适用电机 (kW) Applicable motor	参见GK500产品型号及技术数据表 See the table "Model information of GK500 series"
	额定电流 Rated current	参见GK500产品型号及技术数据表 See the table "Model information of GK500 series"
	输出电压 Output voltage	3相: 0~额定输入电压, 误差小于±3% 3-phase: 0~rated input voltage, error less than ±3%
	输出频率 Output frequency	0.00Hz~600Hz, 单位0.01Hz 0.00Hz~600Hz, Resolution 0.01Hz
	过载能力 Over load capability	150% 1分钟; 180% 10秒; 200% 0.5秒, 间隔10分钟 150% 1min; 180% 10s; 200% 0.5s, once per 10 mins

运行控制特性 Control characteristics	控制方式 Control pattern	V/f控制 V/f control	无PG矢量控制1 Speed-sensorless control 1	无PG矢量控制2 Speed-sensorless control 2
	启动转矩 Start torque	0.5Hz 180%	0.5Hz 180%	0.25Hz 180%
	调速范围 Speed range	1:100	1:100	1:200
	稳速精度 Speed accuracy	±0.5%	±0.2%	±0.2%
	速度波动 Speed ripple	—	±0.3%	±0.3%
	转矩响应时间 Torque response	—	<10ms	<10ms
	启动频率 Start frequency	0.00Hz~600.00Hz		
	加速时间 Accel/Decel time	0.00s~60000s		
	载波频率 Carrier frequency	0.7kHz~16kHz		
	基本功能 Basic functions	频率设定方式 Frequency command modes	数字设定+操作面板Up/Down; 数字设定+端子Up/Down设定; 上位机通讯设定; 面板电位器模拟量输入; 端子模拟量输入 Digital setting +Keypad Up/Down; Digital setting+terminal Up/Down; Communication setting; Keypad POT analog input; Terminals analog input	
启动方式 Start methods		从启动频率启动; 先直流制动再启动; 速度搜索启动 Start from starting frequency; DC injection braking at start; Flying start		
停机方式 Stop methods		减速停机; 自由停车; 减速停机+直流制动 Ramp to stop; Coast to stop; DC injection braking at ramp stop		
能耗制动能力 Dynamic brake capability		额定电压380V: 制动单元动作电压: 650V~750V; 使用时间0.0s~100.0s Rated voltage 380V: Braking unit triggered voltage:650V~750V; Service time: 0.0s~100.0s 额定电压220V: 制动单元动作电压: 400V~450V; 使用时间0.0s~100.0s Rated voltage 220V: Braking unit triggered voltage:400V~450V; Service time: 0.0s~100.0s		
直流制动能力 DC braking capability		直流制动起始频率: 0.00Hz~600.00Hz; 直流制动电流: 恒转矩0~100%; 直流制动时间: 0.0s~30.00s DC braking start frequency: 0.00Hz~600.00Hz; DC braking current: constant torque 0.0~100.0%; DC braking time: 0.0s~30.00s		
输入端子 Input terminals		四个数字输入端子; 一个模拟输入端子, 电压/电流可选 Four digital inputs; One analog input, voltage/current programmable		
输出端子 Output terminals	一个数字输出端子, 一组继电器输出端子, 一个模拟量输出端子(电压/电流分别可选), 可实现设定频率、输出频率等物理量的输出 One digital output, one relay output, and one analog output(voltage/current programmable), can output signals such as command frequency, output frequency, etc.			
特色功能 Characteristic functions	各种主辅给定以及切换、可靠的速度搜索、多种加减速曲线选择、模拟量自动校正、最多可支持8段速运行(两段速支持灵活的频率给定方式)、三组故障记录、过励磁制动、过压失速、欠电压调节、掉电再启动、频率跳跃、频率绑定、四段加减速时间自由切换、过程PID控制、异步机的参数辨识、弱磁控制、高精度的转矩限定 Various master&auxiliary command and switch over, flying start, a variety of Accel/Decel curves programmable, autocorrection of analog, 8-step speed control programmable (2 steps support flexible frequency command), three faults history, over excitation brake, over voltage stall protection programmable, under voltage stall protection programmable, restart upon power loss, skip frequency, frequency binding, four kinds of Accel/Decel time, process PID control, asynchronous motor parameters autotune, field weakening control, precise torque control			
保护功能 Protection	参见GK500说明书第七章故障诊断 Refer to 'Chapter 7 Troubleshooting' in user manual of GK500 series			
环境 Environment	使用场所 Field	室内, 不受阳光直射, 无尘埃、腐蚀性气体、油雾、水蒸气、滴水或盐分等 Indoors, no direct sunlight, free from dust, corrosive gases, flammable gases, oil mist, water vapor, water drop, salt, etc.		
	海拔高度 Altitude	0m~2000m: 1000m以上降额使用, 每升高100m, 额定输出电流减少1% 0m~2000m: de-rate 1% for every 100m when above 1000 meters		
	环境温度 Temperature	-10℃~+50℃ 50℃~60℃之间降额使用, 每升高1℃, 额定输出电流减少1% -10℃~+50℃ 50℃~60℃: rated output current de-rates 1% for every 1℃ above 50℃		
	湿度 Humidity	5%~95%, 不允许凝露 5%~95%, no condensation		
其它 Others	振动 Vibration	小于5.9m/s² (0.6g) Less than 5.9m/s² (0.6g)		
	存储温度 Storage temperature	-40℃~+70℃		
	安装方式 Installation	壁挂式 Wall-mounted		
防护等级 Protection grade	IP20			
冷却方式 Cooling method	强迫风冷 Forced air cooling			

GK500产品外形和安装尺寸
External Dimensions of GK500

电压等级 Voltage	产品型号 Model	外形和安装尺寸(mm) External dimensions					
		W	H	D	W 1	H 1	安装孔d Mounting hole dia.
200V	GK500-2T0.4B	75	166	168	59	154	4.5
	GK500-2T0.75B						
	GK500-2T1.5B	85	188	172	69	175	
	GK500-2T2.2B						
400V	GK500-4T0.75B	75	166	168	59	154	
	GK500-4T1.5B						
	GK500-4T2.2B	85	188	172	69	175	
	GK500-4T3.7B						

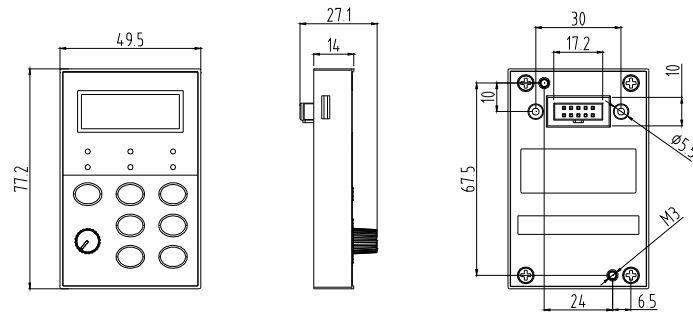

a) 操作面板尺寸
Keypad dimensions

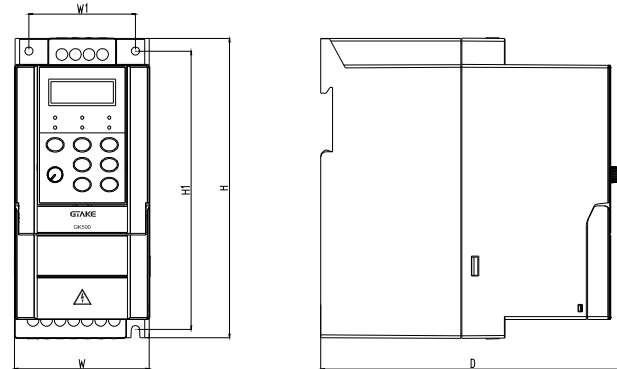

b) GK500机器外形及尺寸
External dimensions of GK500

GK500控制端子功能说明
Specification of GK500 Control Terminals

类别 Category	端子符号 Terminal	端子名称 Terminal designation	技术规格 Specification
模拟量输入 Analog input	+10 V	模拟量输入参考电压 Analog input reference voltage	10.3V±3% 最大输出电流25mA 即外接电位器时需选大于400Ω的电位器 Maximum output current: 25mA Resistance of external potentiometer should be bigger than 400Ω
	GND	模拟地 Analog ground	内部与COM连接 Connected with COM interiorly
	AI	模拟量输入 Analog input	0mA~20mA: 输入阻抗500Ω, 最大输入电流25mA 0mA~20mA: input impedance 500Ω, maximum input current 25mA 0V~10V: 输入阻抗100kΩ, 最大输入电压12.5V 0V~10V: input impedance 100kΩ, maximum input voltage 12.5V 通过拨动开关AI实现0mA~20mA与0V~10V模拟量输入的切换, 出厂默认电压输入 0mA~20mA/0V~10V programmable by switch AI. Factory default: 0~10V
模拟量输出 Analog output	AO	模拟量输出 Analog output	0mA~20mA: 阻抗要求200Ω~500Ω 0mA~20mA: impedance 200Ω~500Ω 0V~10V: 阻抗要求≥10kΩ 0V~10V: impedance ≥10kΩ 通过拨动开关AO实现0mA~20mA与0V~10V模拟量输出的切换, 出厂默认电压输出 Switch AO on control board for jump between 0mA~20mA and 0V~10V output Factory default: 0V~10V
	GND	模拟地 Analog ground	内部与COM连接 Connected with COM interiorly
开关量输入 Digital input	+24V	+24V	24V±10%, 内部与GND连接 24V±10%, connected with GND interiorly 最大负载200mA Maximum load 200mA
	COM	+24V地 +24V ground	内部与GND连接 Connected with GND interiorly
	X1~X4	开关量输入端子1~4 Digital input terminals 1~4	输入规格: 24VDC, 5mA Input: 24VDC, 5mA 频率范围: 0Hz~200Hz Frequency range: 0Hz~200Hz 电压范围: 10V~30V Voltage range: 10V~30V
开关量输出 Digital output	Y	开路集电极输出 Open collector output	电压范围: 0V~24V Voltage range: 0V~24V 电流范围: 0mA~50mA Current range: 0mA~50mA
继电器输出 Relay output	RA/RB/RC	继电器输出 Control board relay output	RA-RB: 常闭; RA-RC: 常开 RA-RB: NC; RA-RC: NO 触点容量: 250VAC/3A, 30VDC/3A Contact capacity: 250VAC/3A, 30VDC/3A
端子485接口 Terminal 485 Interface	485+	485差分信号正 Differential signal 485+	速率: 4800/9600/19200/38400/57600/115200bps Rate: 4800/9600/19200/38400/57600/115200bps
	485-	485差分信号负 Differential signal 485-	最长距离500m(采用标准网线) Maximum distance: 500m (use standard network cable)
	GND	485通讯屏蔽接地 485 communication shielded ground	内部与COM连接 Connected with COM interiorly
操作面板接口 Keypad interface	CN2	操作面板接口 Keypad interface	连接操作面板时最长通讯距离15m Maximum communication distance is 15m when connected to keypad

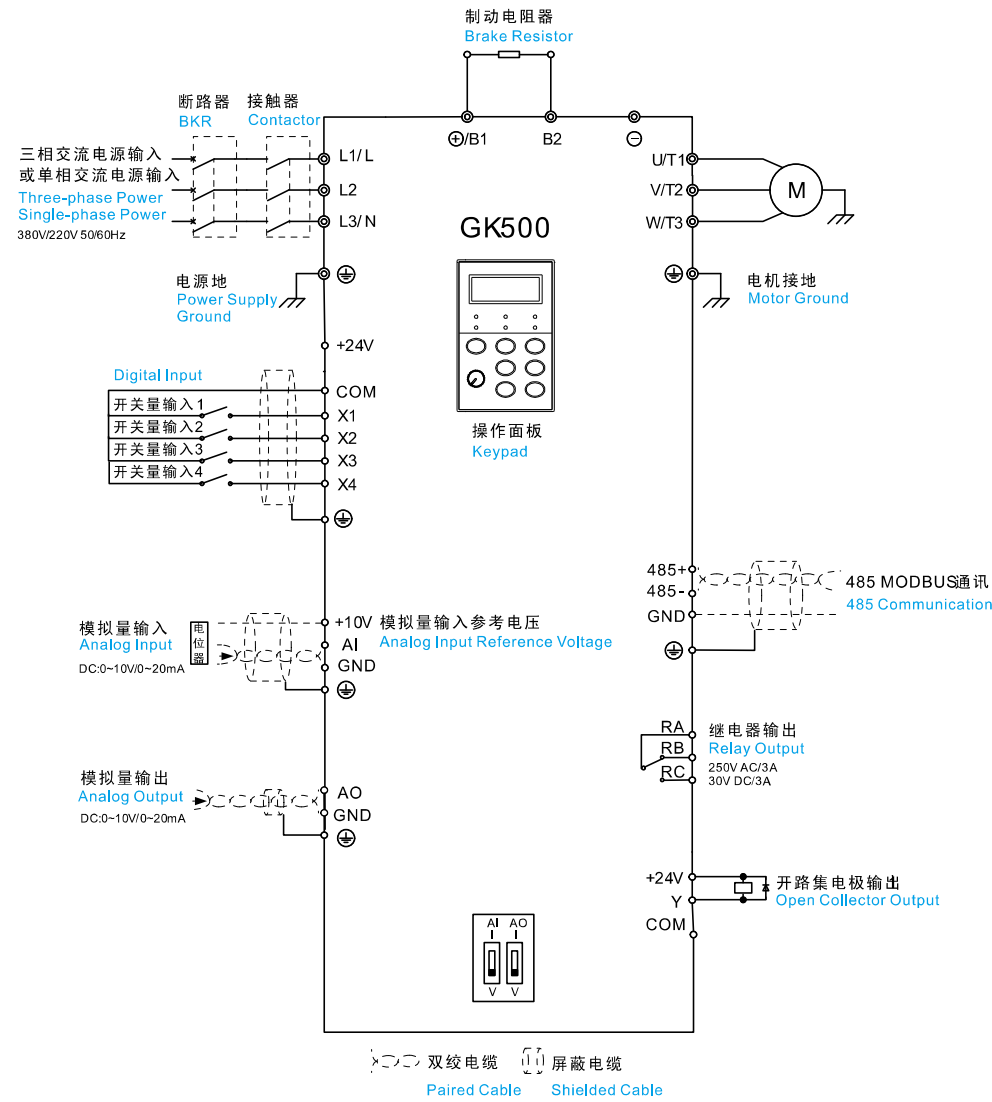

产品外围器件使用说明
Peripheral Devices

名称 Device	使用说明 Instructions
电源 Power supply	输入三相交流电源需满足说明书规定范围 Triphase AC power supply should be in the range specified in user manuals
断路器 Circuit breaker	用途：在后级设备出现异常过流时，起到分断电源，保护后级的作用 选型：断路器的分断电流按变频器额定电流的1.5~2倍选取 断路器的时间特性需根据变频器过载保护的时间特性选取 Purpose: disconnect power supply and protect the equipments when overcurrent occurs Type selection: brake current of circuit breaker should be 1.5~2 times the rated current of the drive; brake time characteristic of circuit breaker should be selected based on overload protection time characteristic of the drive
漏电保护 RCD	用途：由于变频器的输出是PWM高频斩波电压，因此高频漏电流不可避免 选型：建议选B型专用漏电保护器 Purpose: since the drive outputs PWM HF chopping voltage, HF leakage current is inevitable Type selection: type B dedicated RCD is recommended
接触器 Contactor	为了确安全，请不要频繁的闭合和断开接触器，这将引起变频器故障 For safety's sake, do not frequently close and break the contactor as this may bring about equipment faults 不要通过直接对变频器的启停来控制变频器的启停，这将降低变频器的寿命 Do not control the start & stop of the drive directly through switching on and off the contactor since this will result in a reduction on the product life
输入交流电抗器 Input AC reactor	改善功率因数 改善三相输入交流电源不平衡对系统的影响 控制高次谐波，减少对外传导和辐射干扰 有效减少脉冲电流对整流桥的影响 Improve power factor Reduce the impact of imbalanced three-phase input AC power supply on the system Suppress higher harmonics and reduce EMI to peripheral devices Reduce the impact of impulse current on rectifier bridges
输入滤波器 Input filter	减少电源端到变频器的传导干扰，提高变频器抗干扰能力，减少变频器对外传导和辐射干扰 Reduce conducted interference at power supply end, improve the immunity of the drive against noise Reduce conducted and radiated interference of the drive to peripheral devices
制动单元和制动电阻 Brake unit and braking resistor	用途：制动时，有效地消耗电机回馈的能量而实现快速制动 选型：制动单元的选型请直接与我司技术人员联系，制动电阻的选型参考外围器件选型表 Purpose: consume motor feedback energy to attain quick brake Type selection: contact GTAKE technicians for type selection of brake units. Refer to table "Selection of Peripheral Devices" for type selection of brake resistors
输出滤波器 Output filter	减少变频器对外的传导和辐射干扰 Reduce drive EMI to peripheral devices
输出交流电抗器 Output AC reactor	有效避免因谐波电压而损坏电机绝缘 减少因漏电流使得变频器频繁保护 当变频器到电机的连线超过100m时，建议安装输出交流电抗器 Avoid motor insulation damage resulted from harmonic voltage Reduce frequent protection caused by leakage current In case the cable connecting drive and motor is over 100 meters, an output AC reactor is recommended
电机 Motor	选用与变频器匹配的电机 Should match the drive

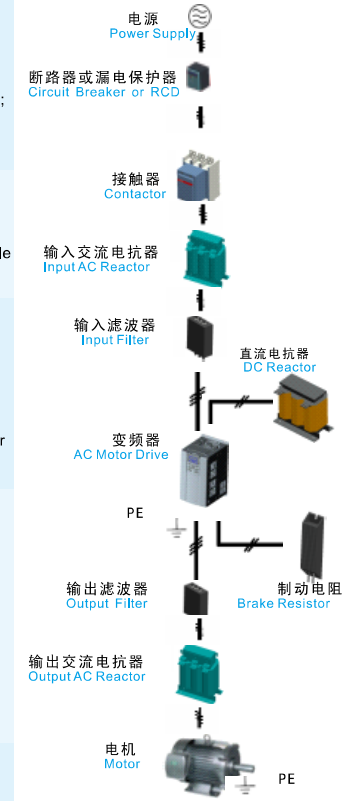

产品外围器件的标准配置图
Standard configuration of peripheral devices

外围器件选型表

Selection of Peripheral Devices

产品型号 Model	断路器 (A) Circuit breaker (A)	接触器 (A) Contactor (A)	制动电阻/制动单元 Brake resistor/brake unit	
			功率 (W) Power (W)	电阻 (Ω) ** Resistance (Ω) **
GK600-4T0.75G/1.5LB	16	10	300	≥150
GK600-4T1.5G/2.2LB	16	10	450	≥100
GK600-4T2.2G/3.7LB	16	10	300	≥150
GK600-4T3.7G/5.5LB	25	16	450	≥100
GK600-4T5.5G/7.5LB	32	25	600	≥75
GK600-4T7.5G/11LB	40	32	600	≥75
GK600-4T11G/15LB	63	40	1200	≥37.5
GK600-4T15G/18.5LB	63	63	1800	≥25
GK600-4T18.5G/22L (B) *	100	63	1800	≥25
GK600-4T22G/30L (B) *	100	100	2500	≥20
GK600-4T30G/37L (B) *	125	100	2500	≥20
GK600-4T37G/45L (B) *	160	100	5000	≥10
GK600-4T45G/55L (B) *	200	125	5000	≥10
GK600-4T55G/75L (B) *	315	250	12000	≥10
GK600-4T75G/90L (B) *	350	330	19200	≥6.8
GK600-4T90G/110L	315	250		
GK600-4T110G/132L	350	330		
GK600-4T132G/160L	400	350		
GK600-4T160G/185L	500	400		
GK600-4T185G/200L	500	400		
GK600-4T200G/220L	600	500		
GK600-4T220G/250L	600	600		
GK600-4T250G/280L	800	600		
GK600-4T280G/315L	800	800		
GK600-4T315G/355L	800	800		
GK600-4T355G/400L	800	800		
GK600-4T400G/450L	1000	1000		
GK600-4T450G/500L	1600	1250		
GK600-4T500G	1600	1250		
GK600-4T560G	2000	1600		
GK600-4T630G	2000	1600		

选配制动单元
External brake unit optional

* 内置制动单元时，制动电阻功率和阻值需满足表中要求；外配制动单元时，制动电阻功率和阻值依据所选制动单元来配置。

* When brake unit is inbuilt, the power and resistance of brake resistor should meet the requirement stated in the table. When brake unit is mounted externally, the power and resistance of brake resistor should be in accordance with brake unit.

** 在满足制动要求的前提下，制动电阻应大于表中规定的最小值，否则有产品损坏的危险！
制动电阻都不内置，需要另外采购。

** On the premise of fulfilling brake requirement, brake resistance value might be bigger than the minimum value stated in the table. Failure to comply may result in product damage. Brake resistors are not inbuilt and need to be sourced additionally.

吉泰科公司注册于南通，总部位于深圳；在南通、新疆建立了库存中心，覆盖全国市场。

Nantong is the registered address of GTAKE, while the headquarters are located in Shenzhen. Inventory centers have been setup in Nantong and Xinjiang, covering all domestic territories.

在国内有22个办事处，陆续会增设新的办事处、联保中心、备件中心；营销服务网络遍布全国；我们凭借多年来在工业自动化行业领先的驱动器技术以及丰富的经验，为客户提供全方位的配套驱动解决方案。

There are 22 branch offices spread across China so far, and we are setting up more new offices, warranty service centers, spare part centers, to render better services nationwide. Thanks to our leading drive technology in automation industry, and a great deal of field experience, complete drive and control solutions are provided for our customers worldwide.



全国服务热线(Hotline): 0755-86392662