

©本公司保留更改产品设计与规格的权利，如有变更恕不另行通知。
如产品图片与实物有所区别，以实物为准。
如有任何印刷错漏或翻译上的错误，望广大用户谅解。

总策划/监制：滕州市润发机械有限公司 版权所有 翻印必究
设计/印刷/摄影：光采印务 0632-5695559 13856379916 www.gcyw.cn

滕州市润发机械有限责任公司

地址：山东省滕州市东郭镇罗庄工业园
销售部电话：0632-2522836 2521987
2521136

传真：0632-2537568

售后服务热线：0632-2521136

网址：<http://www.tzrf.com>

<http://www.runfamc.com>

企业邮箱：runfa@tzrf.com

runfa@runfamc.com

邮编：277533

润发销售公司

地址：山东省滕州市北辛路386号

销售部电话：0632-5813836

网址：<http://www.tzrfxs.com>

邮箱：runfa@tzrfxs.com

邮编：277500

TENGZHOU RUNFA MACHINERY CO.,LTD

Address: Luozhuang industrial Zone,DongguoTown,
Tengzhou,Shandong P.R.,China

SalesTel: + 86 - 632 - 2522836 2521987 2521136

Fax: + 86 - 632 - 2537568

Service Tel: +86 - 632 - 2521136

Web Site: <http://www.tzrf.com>

<http://www.runfamc.com>

E - mail : runfa@tzrf.com

runfa@runfamc.com

P.C: 277533

RUNFA SALES COMPANY

Add:No.386 Beixin Road,Tengzhou,Shandong P.R.,China

Sales Tel:+86 - 632 - 5813836

Web Site:<http://www.tzrfxs.com>

E - mail:runfa@tzrfxs.com

P.C:277500

RUNFA MACHINE AIR HAMMER



滕州市润发机械有限责任公司
TENGZHOU RUNFA MACHINERY CO.,LTD

润发机械 空气锤

www.tzrf.com

润发机械 以质取胜

Runfa Machinery Using Quality To Compete

RUNFA MACHINE
AIR HAMMER

TENGZHOU RUNFA MACHINERY CO.,LTD

润发空气锤

2016 版





滕州市润发机械有限责任公司

RUNFA MACHINE AIR HAMMER

滕州市润发机械有限责任公司系国家机械电子工业部定点生产锻压、钻铣、冲剪设备的专业企业。本公司集产品的研发、设计、生产、制造、销售、服务于一体，产品通过ISO9002国际质量标准认证，并取得了出口质量许可证，主导产品有C41系列空气锤、Z系列摇臂钻床、GT系列金属带锯床、牛头刨床、ZX系列多功能钻铣床、X系列万能升降台铣床、YQ系列剪断机、J21S、J23系列深喉、可倾压力机、Q11系列剪板机等产品，功能齐全、质量优良。具有锻打、切、铣、钻、刨、扩、铰、镗、磨、切、削、冲、剪及攻丝之功能，同时配有与其相配套的各种辅助附件，产品外形美观，坚固耐用，质量可靠。雄厚的经济实力，先进的技术设备，完善的检测手段，务实的工作作风，以及优秀的全程管理，构筑了企业产品的优良品质。产品销往全国各地及海外市场，深受广大用户的赞誉和信赖。

滕州市润发机械有限责任公司将始终遵循：“以人为本、技术先导、品质卓越、服务真诚”的经营理念。我们愿与所有客户一道共创一个真诚友好、融洽、合作的经营空间，在“合力”的品牌下，本着互利双赢的原则，将永远与您精诚合作，共同开创辉煌的明天。

科技创新

TECHNOLOGY INNOVATION

以市场为导向，以质量为生命，靠创新求发展

TAKE THE MARKET AS THE GUIDANCE, TAKE THE QUALITY AS THE LIFE, SEEK DEVELOPMENT BY INNOVATION

COMPANY PROFILE

Tengzhou Runfa Machinery Co.,Ltd appointed by Ministry of Machine Building & Electronics Industry of China is an enterprise specialized in manufacturing press forging, drilling, milling,drilling & milling, punching equipment etc. It is engaged in product self - research and development, design, production, manufacture, sale, service and the product have passed ISO9001 international quality system certification and acquired export quality licence . Our main product includes C41 series pneumatic(air) hammer, Z series radial drilling machine,GT series band sawing machine,shaping machine,ZX series multifunctional drilling & milling machine, X series universal vertical knee-type milling machine, hydraulic pressing machine, Q11 series plate shears and other products with complete function and excellent quality.Our company's product with function of forging ,cutting,milling,d rilling,planing,expanding,reaming,boring,grinding,cutting,punching ,tapping and also equipped with the various auxiliary attachments suitable for the equipment not only are beautiful in appearance,but also durable and reliable. The powerful economic strength,the advanced technology and equipment,the consummate inspection,the pragmatic style of work and the outstanding management have constructed the good quality of our enterprise's production.Our company's product is sold all over the world and winning greatest honors from our customers after using around the world.

We always follow management philosophy: "people-oriented, forefront technology, excellent quality, sincere service". We wish with all our customers together to create a sincere, friendly, harmonious and cooperative business space. Under the "HELI"(joint effort) brand, we will cooperate with you sincerely and create a brilliant future with the principle of "win-win" and mutual benefit.





C41-6kg 单体式 RUNFA AIR HAMMER

滕州市润发公司自主设计研发了C41-6KG微型空气锤，该机为全球首创，填补了全球微型空气锤的空白。该机设计独特，新颖，机身微小，操作方便，采用电机和机身一体式结构；传动部分为齿轮传动；特别是锤杆设计独特，可随意更换模具，加工各种微型产品，特别对金银、首饰加工非常灵活。运转低噪音，坚固耐用，成为工匠们的理想的致富好帮手。

Tengzhou Runfa Machinery company independently design and development of the C41-6KG miniature air hammer, it is the world's first origination to fill the gaps in the global micro air hammer. Using motor and frame body assemble together structure. The unique and novel design of the forging hammer with small body is easy to operate. Transmission is drove by gear transmission. Especially the unique hammer holder design, it can easily replace the hammer die. It can be used for making all kinds of micro-products, particularly for golden and silver jewelry processing is very flexible. Since its less noise, durable and stable function make it to be one ideal helper to become wealthy for craftsman.



C41-6kg 单体带底座 RUNFA AIR HAMMER

主要特点

- 机身设计小巧灵活，方便搬运
- 结构合理，噪音低，操作方便
- 易换模具，适宜小型锻件加工
- 性能稳定，坚固耐用

Main Features

- With small frame body, easy to carry and move
- With reasonable structure and less noise, easy to operate
- Easy to replace hammer die, fit to forge small workpiece
- With stable function and durable frame



参数/项目/型号	SPECIFICATION	UNIT	C41-6KG
落下部分重量	Weight of falling parts	kg	6
打击能量	Max.hit energy	kj	0.066
打击次数	Hit number	min ⁻¹	248
锤杆导程底面至下砧块距离	Distance from hammer guide bottom surface to bottom hammer die	mm	175
锤杆中心线至锤身距离	Distance from hammer ram centerline to hammer frame	mm	100
电动机功率	Rate Power	kw	0.75(3相/phase)1.1 (单相/single phase)
电动机转速	Speeds of motor	r.p.m	1440
外形尺寸	Overall dimensions (LxWxH)	mm	480 × 340 × 670
总重量	Total weight	kg	126

参数/项目/型号	SPECIFICATION	UNIT	C41-6KG
落下部分重量	Weight of falling parts	kg	6
打击能量	Max.hit energy	kj	0.066
打击次数	Hit number	min ⁻¹	248
锤杆导程底面至下砧块距离	Distance from hammer guide bottom surface to bottom hammer die	mm	175
锤杆中心线至锤身距离	Distance from hammer ram centerline to hammer frame	mm	100
电动机功率	Rate Power	kw	0.75(3相/phase)1.1 (单相/single phase)
电动机转速	Speeds of motor	r.p.m	1440
外形尺寸	Overall dimensions (LxWxH)	mm	470 × 370 × 1060
总重量	Total weight	kg	166



润发空气锤
RUNFA MACHINE
AIR HAMMER

C41-16kg
单体式
SINGLE HAMMER
RUNFA AIR HAMMER



参数/项目/型号	SPECIFICATION	UNIT	C41-16KG单体式
落下部分重量	Weight of falling parts	kg	16
打击能量	Max.hit energy	KJ	0.18
工作区间高度	Height of working area	mm	180
打击次数	Hit number	min ⁻¹	258
上下砧块尺寸	Dimension of top and bottom die surface(L×W)	mm	70×40
可锻方钢边长	Max.square steel can be forged	mm	20×20
可锻圆钢边长	Max.round steel can be forged(Diameter)	mm	Φ22
配用功率	Rate Power	KW	单相 1.5/220 三相1.5/380
电机转速	Speeds of motor	r.p.m	1440
总重量	Total weight	kg	240
外形尺寸	Overall dimensions (L×W×H)	mm	660×420×970

C41系列空气锤
C41 SERIES PNEUMATIC HAMMER

RUNFA MACHINE AIR HAMMER
TENGZHOU RUNFA MACHINERY CO.,LTD

C41-20kg
分体式
RUNFA AIR HAMMER
追求品质 完美制造每一个小细节
THE PURSUIT OF QUALITY PERFECT
MANUFACTURING EVERY LITTLE DETAIL



参数/项目/型号	SPECIFICATION	UNIT	C41-20KG
落下部分重量	Weight of falling parts	kg	20
打击能量	Max.hit energy	KJ	0.22
工作区间高度	Height of working area	mm	200
打击次数	Hit number	min ⁻¹	255
上下砧块尺寸	Dimension of top and bottom die surface(L×W)	mm	90×50
可锻方钢边长	Max.square steel can be forged	mm	30×30
可锻圆钢边长	Max.round steel can be forged(Diameter)	mm	Φ35
配用功率	Rate Power	KW	单相2.2/220 三相2.2/380
电机转速	Speeds of motor	r.p.m	1440
砧座重量	Anvil weight	kg	190
总重量	Total weight	kg	500
外形尺寸	Overall dimensions (L×W×H)	mm	820×460×1110



润发空气锤
RUNFA MACHINE
AIR HAMMER

C41系列空气锤
C41 SERIES PNEUMATIC HAMMER

RUNFA MACHINE AIR HAMMER
TENGZHOU RUNFA MACHINERY CO.,LTD



C41-16kg
单体式带底座
MONOMER TYPE BASE
RUNFA AIR HAMMER



C41-20kg
单体式带底座
SINGLE WITH BASE PLATE
RUNFA AIR HAMMER

参数/项目/型号	SPECIFICATION	UNIT	C41-16KG单体式带底座
落下部分重量	Weight of falling parts	kg	16
打击能量	Max.hit energy	KJ	0.18
工作区间高度	Height of working area	mm	180
打击次数	Hit number	min ⁻¹	258
上下砧块尺寸	Dimension of top and bottom die surface(L×W)	mm	70×40
可锻方钢边长	Max.square steel can be forged	mm	20×20
可锻圆钢边长	Max.round steel can be forged(Diameter)	mm	Φ22
配用功率	Rate Power	KW	单相 1.5/220 三相 1.5/380
电机转速	Speeds of motor	r.p.m	1440
底座重量	Weight of base plate	kg	40
总重量	Total weight	kg	290
外形尺寸	Overall dimensions (L×W×H)	mm	800×420×1170

参数/项目/型号	SPECIFICATION	UNIT	C41-20KG单体式带底座
落下部分重量	Weight of falling parts	kg	20
打击能量	Max.hit energy	KJ	0.22
工作区间高度	Height of working area	mm	200
打击次数	Hit number	min ⁻¹	255
上下砧块尺寸	Dimension of top and bottom die surface(L×W)	mm	90×50
可锻方钢边长	Max.square steel can be forged	mm	30×30
可锻圆钢边长	Max.round steel can be forged(Diameter)	mm	Φ35
配用功率	Rate Power	KW	单相 2.2/220 三相 2.2/380
电机转速	Speeds of motor	r.p.m	1440
底座重量	Weight of base plate	kg	60
总重量	Total weight	kg	460
外形尺寸	Overall dimensions (L×W×H)	mm	970×460×1310



润发空气锤
RUNFA MACHINE
AIR HAMMER

C41系列空气锤
C41 SERIES PNEUMATIC HAMMER

RUNFA MACHINE AIR HAMMER
TENGZHOU RUNFA MACHINERY CO.,LTD

C41-20kg
单体式
SINGLE HAMMER
RUNFA AIR HAMMER



C41-25kg
单体式
SINGLE HAMMER
RUNFA AIR HAMMER



参数/项目/型号	SPECIFICATION	UNIT	C41-20KG单体式
落下部分重量	Weight of falling parts	kg	20
打击能量	Max.hit energy	KJ	0.22
工作区间高度	Height of working area	mm	200
打击次数	Hit number	min ⁻¹	255
上下砧块尺寸	Dimension of top and bottom die surface(L×W)	mm	90×50
可锻方钢边长	Max.square steel can be forged	mm	30×30
可锻圆钢边长	Max.round steel can be forged(Diameter)	mm	Φ35
配用功率	Rate Power	KW	单相 2.2/220 三相2.2/380
电机转速	Speeds of motor	r.p.m	1440
总重量	Total weight	kg	380
外形尺寸	Overall dimensions (L×W×H)	mm	820×460×1110

参数/项目/型号	SPECIFICATION	UNIT	C41-25KG单体式
落下部分重量	Weight of falling parts	kg	25
打击能量	Max.hit energy	KJ	0.27
工作区间高度	Height of working area	mm	240
打击次数	Hit number	min ⁻¹	250
上下砧块尺寸	Dimension of top and bottom die surface(L×W)	mm	100×50
可锻方钢边长	Max.square steel can be forged	mm	40×40
可锻圆钢边长	Max.round steel can be forged(Diameter)	mm	Φ45
配用功率	Rate Power	KW	单相 3/220 三相2.2/380
电机转速	Speeds of motor	r.p.m	1440
总重量	Total weight	kg	560
外形尺寸	Overall dimensions (L×W×H)	mm	980×510×1200



润发空气锤
RUNFA MACHINE
AIR HAMMER



C41系列空气锤
C41 SERIES PNEUMATIC HAMMER

RUNFA MACHINE AIR HAMMER
TENGZHOU RUNFA MACHINERY CO.,LTD

C41-25kg
单体式带底座
SINGLE WITH BASE PLATE
RUNFA AIR HAMMER



C41-40kg
单体式带底座
RUNFA AIR HAMMER



主要特点

- 安装方便，可移动工作
- 钢板厚度可定做
- 底座高度可根据客户要求定做
- 操作方便，噪音低，打击能量大

Main Features

- Easy installation and movable to anywhere you need
- The steel thickness of base plate can be customized
- The high of base plate can be customized by customers's requirement
- Easy operation, less noise and more hit power energy

参数/项目/型号	SPECIFICATION	UNIT	C41-25KG单体式带底座
落下部分重量	Weight of falling parts	kg	25
打击能量	Max.hit energy	KJ	0.27
工作区间高度	Height of working area	mm	240
打击次数	Hit number	min ⁻¹	250
上下砧块尺寸	Dimension of top and bottom die surface(LxW)	mm	100 × 50
可锻方钢边长	Max.square steel can be forged	mm	40 × 40
可锻圆钢边长	Max.round steel can be forged(Diameter)	mm	Φ45
配用功率	Rate Power	KW	单相 3/220 三相 2.2/380
电机转速	Speeds of motor	r.p.m	1440
底座重量	Weight of base plate	kg	80
总重量	Total weight	kg	640
外形尺寸	Overall dimensions (LxWxH)	mm	1150 × 510 × 1400

参数/项目/型号	SPECIFICATION	UNIT	C41-40KG单体式带底座
落下部分重量	Weight of falling parts	kg	40
打击能量	Max.hit energy	KJ	0.53
工作区间高度	Height of working area	mm	245
打击次数	Hit number	min ⁻¹	245
上下砧块尺寸	Dimension of top and bottom die surface(LxW)	mm	120 × 50
可锻方钢边长	Max.square steel can be forged	mm	52 × 52
可锻圆钢边长	Max.round steel can be forged(Diameter)	mm	Φ68
配用功率	Rate Power	KW	4
电机转速	Speeds of motor	r.p.m	1440
底座重量	Weight of base plate	kg	100
总重量	Total weight	kg	980
外形尺寸	Overall dimensions (LxWxH)	mm	1220 × 600 × 1630



润发空气锤
RUNFA MACHINE
AIR HAMMER

C41-25kg
RUNFA AIR HAMMER

以人为本 技术先导
品质卓越 服务真诚

PEOPLE-ORIENTED, TECHNOLOGY LEADER,
EXCELLENT QUALITY, SINCERE SERVICE



参数/项目/型号	SPECIFICATION	UNIT	C41-25KG
落下部分重量	Weight of falling parts	kg	25
打击能量	Max.hit energy	KJ	0.27
工作区间高度	Height of working area	mm	240
打击次数	Hit number	min ⁻¹	250
上下砧块尺寸	Dimension of top and bottom die surface(LxW)	mm	100 × 50
可锻方钢边长	Max.square steel can be forged	mm	40 × 40
可锻圆钢边长	Max.round steel can be forged(Diameter)	mm	Φ45
配用功率	Rate Power	KW	单相3/220 三相2.2/380
电机转速	Speeds of motor	r.p.m	1440
砧座重量	Anvil weight	kg	250
总重量	Total weight	kg	760
外形尺寸	Overall dimensions (LxWxH)	mm	900 × 510 × 1200

C41系列空气锤
C41 SERIES PNEUMATIC HAMMER

RUNFA MACHINE AIR HAMMER
TENGZHOU RUNFA MACHINERY CO.,LTD

C41-40kg
分体式
SEPARATED TYPE
RUNFA AIR HAMMER



参数/项目/型号	SPECIFICATION	UNIT	C41-40KG
落下部分重量	Weight of falling parts	kg	40
打击能量	Max.hit energy	KJ	0.53
工作区间高度	Height of working area	mm	245
打击次数	Hit number	min ⁻¹	245
上下砧块尺寸	Dimension of top and bottom die surface(LxW)	mm	120 × 50
可锻方钢边长	Max.square steel can be forged	mm	52 × 52
可锻圆钢边长	Max.round steel can be forged(Diameter)	mm	Φ68
配用功率	Rate Power	KW	4
电机转速	Speeds of motor	r.p.m	1440
砧座重量	Anvil weight	kg	400
总重量	Total weight	kg	1350
外形尺寸	Overall dimensions (LxWxH)	mm	1080 × 600 × 1430



润发空气锤

RUNFA MACHINE AIR HAMMER

C41-40kg 单体式

SINGLE HAMMER

RUNFA AIR HAMMER



C41系列空气锤

C41 SERIES PNEUMATIC HAMMER

RUNFA MACHINE AIR HAMMER

TENGZHOU RUNFA MACHINERY CO.,LTD

C41-40kg 分体式带底座

SEPARATE WITH THE BASE

主要特点

- 外型设计新颖，方便移动
- 整机工作效率高，打击能量大
- 底座采用特殊钢板焊接，坚固耐用
- 工作噪音低

Main Features

- New and unique designed shape for convenient movement
- With high efficiency and more powerful hit energy,
- The base plate welded with special steel, more stable and durable,
- With less noise



参数/项目/型号	SPECIFICATION	UNIT	C41-40KG单体式
落下部分重量	Weight of falling parts	kg	40
打击能量	Max.hit energy	KJ	0.53
工作区间高度	Height of working area	mm	245
打击次数	Hit number	min ⁻¹	245
上下砧块尺寸	Dimension of top and bottom die surface(L×W)	mm	120×50
可锻方钢边长	Max.square steel can be forged	mm	52×52
可锻圆钢边长	Max.round steel can be forged(Diameter)	mm	Φ68
配用功率	Rate Power	KW	4
电机转速	Speeds of motor	r.p.m	1440
总重量	Total weight	kg	880
外形尺寸	Overall dimensions (L×W×H)	mm	1080×600×1430

参数/项目/型号	SPECIFICATION	UNIT	C41-40KG分体式带底座
落下部分重量	Weight of falling parts	kg	40
打击能量	Max.hit energy	KJ	0.53
工作区间高度	Height of working area	mm	245
打击次数	Hit number	min ⁻¹	245
上下砧块尺寸	Dimension of top and bottom die surface(L×W)	mm	120×50
可锻方钢边长	Max.square steel can be forged	mm	52×52
可锻圆钢边长	Max.round steel can be forged(Diameter)	mm	Φ68
配用功率	Rate Power	KW	4
电机转速	Speeds of motor	r.p.m	1440
底座重量	Weight of base plate	kg	150
总重量	Total weight	kg	1500
外形尺寸	Overall dimensions (L×W×H)	mm	1500×670×1800



润发空气锤
RUNFA MACHINE
AIR HAMMER



C41系列空气锤
C41 SERIES PNEUMATIC HAMMER

RUNFA MACHINE AIR HAMMER
TENGZHOU RUNFA MACHINERY CO.,LTD

C41-55kg
RUNFA AIR HAMMER

杰出的加工性能、一流的制造工艺

EXCELLENT PROCESSING PERFORMANCE,
FIRST-CLASS MANUFACTURING PROCESS



C41-75kg
RUNFA AIR HAMMER



参数/项目/型号	SPECIFICATION	UNIT	C41-55KG
落下部分重量	Weight of falling parts	kg	55
打击能量	Max.hit energy	KJ	0.7
工作区间高度	Height of working area	mm	265
打击次数	Hit number	min ⁻¹	230
上下砧块尺寸	Dimension of top and bottom die surface(LxW)	mm	120 × 55
可锻方钢边长	Max.square steel can be forged	mm	52 × 52
可锻圆钢边长	Max.round steel can be forged(Diameter)	mm	Φ68
配用功率	Rate Power	KW	5.5
电机转速	Speeds of motor	r.p.m	1440
砧座重量	Anvil weight	kg	600
总重量	Total weight	kg	1700
外形尺寸	Overall dimensions (LxWxH)	mm	1320 × 670 × 1620

参数/项目/型号	SPECIFICATION	UNIT	C41-75KG
落下部分重量	Weight of falling parts	kg	75
打击能量	Max.hit energy	KJ	1
工作区间高度	Height of working area	mm	300
打击次数	Hit number	min ⁻¹	210
上下砧块尺寸	Dimension of top and bottom die surface(LxW)	mm	145 × 65
可锻方钢边长	Max.square steel can be forged	mm	65 × 65
可锻圆钢边长	Max.round steel can be forged(Diameter)	mm	Φ85
配用功率	Rate Power	KW	7.5
电机转速	Speeds of motor	r.p.m	1440
砧座重量	Anvil weight	kg	850
总重量	Total weight	kg	2800
外形尺寸	Overall dimensions (LxWxH)	mm	1400 × 760 × 1950



润发空气锤

RUNFA MACHINE AIR HAMMER

C41-150kg

RUNFA AIR HAMMER

主要特点

- 机身采用高强度铸铁铸造，树脂砂型铸造
- 噪声低、结构合理、操作方便
- 适用于各种自由锻造

Main Features

- The body forged with high-strength cast iron. resin sand casting technics
- With low noise,reasonable structure,convenient operation
- Suitable for all kinds of forging works.



参数/项目/型号	SPECIFICATION	UNIT	C41-150KG
落下部分重量	Weight of falling parts	kg	150
打击能量	Max.hit energy	KJ	2.2
工作区间高度	Height of working area	mm	370
打击次数	Hit number	min ⁻¹	180
上下砧块尺寸	Dimension of top and bottom die surface(L×W)	mm	200 × 85
可锻方钢边长	Max.square steel can be forged	mm	130 × 130
可锻圆钢边长	Max.round steel can be forged(Diameter)	mm	Φ145
配用功率	Rate Power	KW	15
电机转速	Speeds of motor	r.p.m	1470
砧座重量	Anvil weight	kg	1800
总重量	Total weight	kg	5060
外形尺寸	Overall dimensions (L×W×H)	mm	2080 × 1240 × 2350

C41系列空气锤

C41 SERIES PNEUMATIC HAMMER

RUNFA MACHINE AIR HAMMER

TENGZHOU RUNFA MACHINERY CO.,LTD

C41-250kg

RUNFA AIR HAMMER

主要特点

- 结构简单、操作方便、动作灵活
- 机身采用高强度铸铁铸造
- 适用于各种自由锻造

Main Features

- Simple structure,easy operation,act flexible
- Machine body use high strength cast iron
- Suitable for many kinds of free forge work



参数/项目/型号	SPECIFICATION	UNIT	C41-250KG
落下部分重量	Weight of falling parts	kg	250
打击能量	Max.hit energy	KJ	5.6
工作区间高度	Height of working area	mm	450
打击次数	Hit number	min ⁻¹	150
上下砧块尺寸	Dimension of top and bottom die surface(L×W)	mm	220 × 100
可锻方钢边长	Max.square steel can be forged	mm	145 × 145
可锻圆钢边长	Max.round steel can be forged(Diameter)	mm	Φ175
配用功率	Rate Power	KW	22
电机转速	Speeds of motor	r.p.m	1470
砧座重量	Anvil weight	kg	2800
总重量	Total weight	kg	8200
外形尺寸	Overall dimensions (L×W×H)	mm	2875 × 1405 × 2570



润发空气锤
RUNFA MACHINE
AIR HAMMER



C41系列空气锤
C41 SERIES PNEUMATIC HAMMER

RUNFA MACHINE AIR HAMMER
TENGZHOU RUNFA MACHINERY CO.,LTD

C41-400kg
RUNFA AIR HAMMER
高精度的最佳利器
HIGH PRECISION OF THE BEST TOOL



C41-560kg
RUNFA AIR HAMMER



参数/项目/型号	SPECIFICATION	UNIT	C41-400KG
落下部分重量	Weight of falling parts	kg	400
工作区间高度	Height of working area	mm	530
打击次数	Hit number	min ⁻¹	120
能锻方钢最大断面	Max.square steel can be forged	mm	220 × 220
能锻圆钢最大直径	Max.round steel can be forged(Diameter)	mm	Φ240
最大打击能量	Max.hit energy	KJ	9.5
电动机	型号	Motor model	Y225S-4
	功率	Rate Power	37
	转速	Speeds of motor	1480
砧座重量	ANVIL weight	kg	4800
总重量	Total weight	kg	12800
外形尺寸	Overall dimensions (L×W×H)	mm	2785 × 1400 × 2885
其他参数	Other parameters	-	按国家和行业相关标准

参数/项目/型号	SPECIFICATION	UNIT	C41-560KG
落下部分重量	Weight of falling parts	kg	560
工作区间高度	Height of working area	mm	600
打击次数	Hit number	min ⁻¹	115
能锻方钢最大断面	Max.square steel can be forged	mm	270 × 270
能锻圆钢最大直径	Max.round steel can be forged(Diameter)	mm	Φ280
最大打击能量	Max.hit energy	KJ	13.6
电动机	型号	Motor model	Y28S-6
	功率	Rate Power	45
	转速	Speeds of motor	980
砧座重量	ANVIL weight	kg	6720
总重量	Total weight	kg	16520
外形尺寸	Overall dimensions (L×W×H)	mm	3464 × 1500 × 3157
其他参数	Other parameters	-	按国家和行业相关标准



润发空气锤
RUNFA MACHINE
AIR HAMMER



C41系列空气锤
C41 SERIES PNEUMATIC HAMMER

RUNFA MACHINE AIR HAMMER
TENGZHOU RUNFA MACHINERY CO.,LTD

C41-750kg
RUNFA AIR HAMMER
润发机械 以质取胜
Runfa Machinery Using Quality To Compete



C41-1000kg
RUNFA AIR HAMMER



参数/项目/型号	SPECIFICATION	UNIT	C41-750KG
落下部分重量	Drop some weight	kg	750
工作区间高度	Height of working area	mm	670
打击次数	Hit number	min ⁻¹	105
能锻方钢最大断面	Max.square steel can be forged	mm	270 × 270
能锻圆钢最大直径	Max.round steel can be forged(Diameter)	mm	Φ300
最大打击能量	Max.hit energy	KJ	19
电动机	型号	Motor model	Y280M-6
	功率	Rate Power	55
	转速	Speeds of motor	980
砧座重量	ANVIL weight	kg	9000
总重量	Total weight	kg	26000
外形尺寸	Overall dimensions (L×W×H)	mm	3095 × 1370 × 3175
其他参数	Other parameters	-	按国家和行业相关标准

参数/项目/型号	SPECIFICATION	UNIT	C41-1000KG
落下部分重量	Drop some weight	kg	1000
工作区间高度	Height of working area	mm	800
打击次数	Hit number	min ⁻¹	95
能锻方钢最大断面	Max.square steel can be forged	mm	290 × 290
能锻圆钢最大直径	Max.round steel can be forged(Diameter)	mm	Φ320
最大打击能量	Max.hit energy	KJ	27
电动机	型号	Motor model	Y315S-6
	功率	Rate Power	75
	转速	Speeds of motor	980
砧座重量	ANVIL weight	kg	13000
总重量	Total weight	kg	32840
外形尺寸	Overall dimensions (L×W×H)	mm	770 × 1500 × 4125
其他参数	Other parameters	-	按国家和行业相关标准

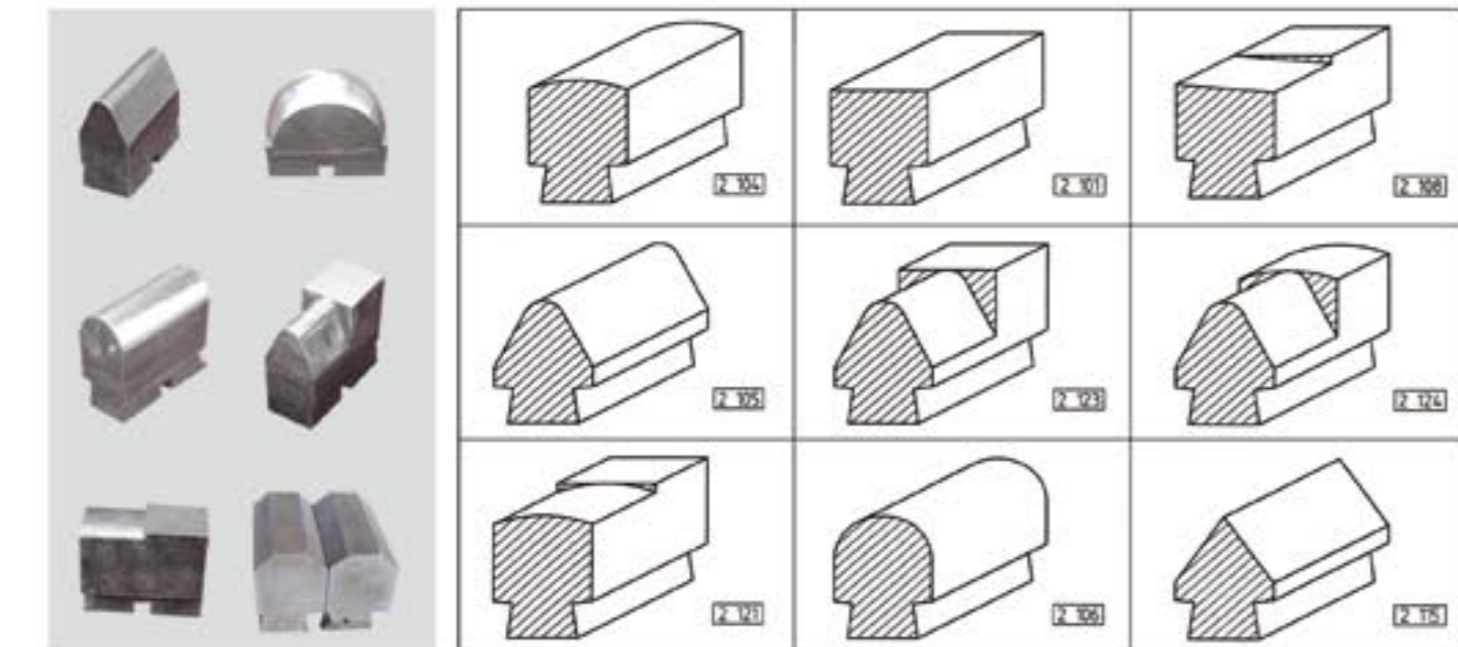
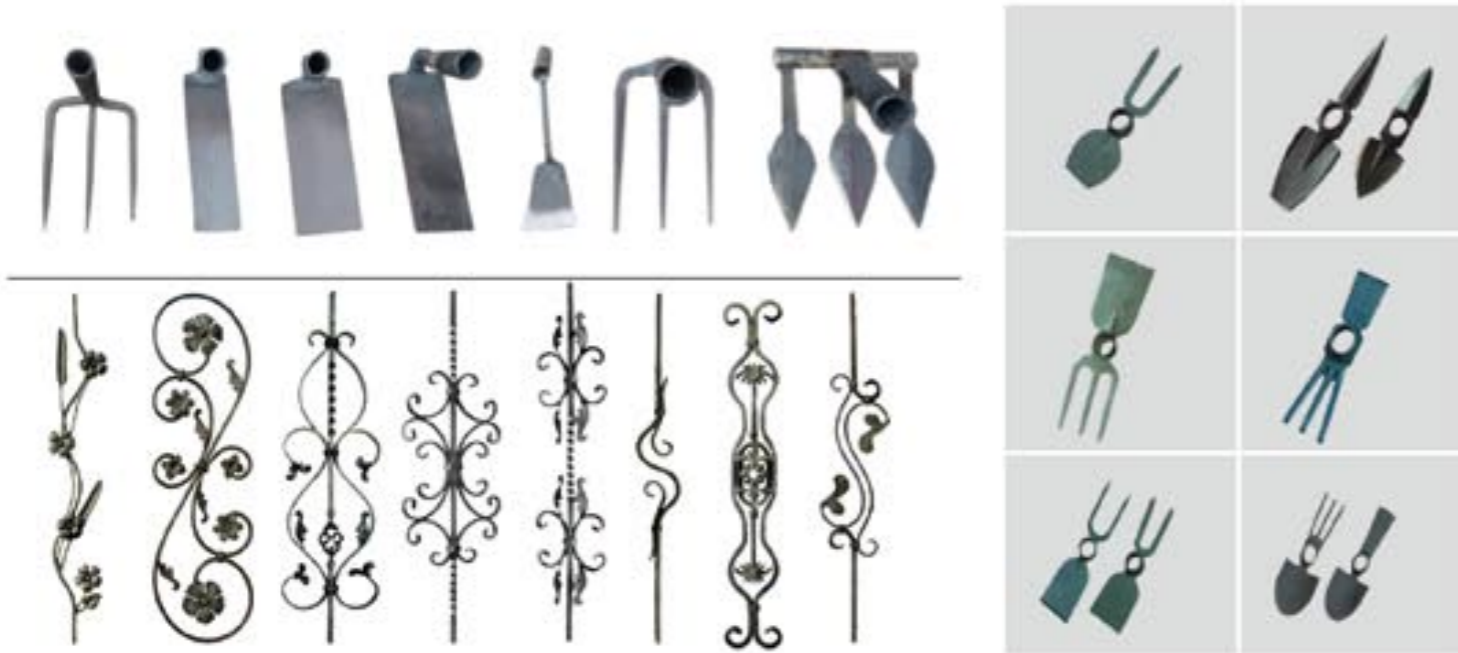

羊角砧子 CLAW ANVIL

- 铸钢铁砧、羊角砧
采用全新先进工艺铸钢浇注，具有高强度、高韧性。
价廉物美，经久耐用；适合船厂、钣金和样品测试等。
- Cast steel anvil, claw anvil
Using new advanced casting steel casting process, with high strength and high toughness.
Cheap and fine, durable; Suitable for shipyard, sheet metal and sample test, etc.



- 砧子重量规格：
砧子重量分为50kg、68kg、120kg多种规格，用户可根据自己的需要做不同的选择
- The anvil specifications:
Anvil weight 50 kg, 68 kg, 120 kg a variety of specifications, the user can choose according to their own needs to do different



- 系列空气锤可根据客户要求加工定做，各种工艺改造
- 可定做各种异型锤头模具
- This series air hammer can be special customized according to customers' processing requirement,
- In order to satisfy different craftsman, we provide many optional different type hammer dies for them.