

DESCRIPTION MACHINE CA7 nr 112

5 axes grinding center



YEAR OF CONSTRUCTION : JULY 2017





CHARACTERISTICS OF THE NUMAFFUT CA7 nr 112

☐ Strokes and capacity

Strokes			
Horizontal	mm	X: 1500	m/mn
Vertical	mm	Y: 350	m/mn
Transversal	mm	Z: 400	m/mn
Axe A		∞	650 Rpm
Axe B		-45°/+180° (1)	30 Rpm
RESOLUTION			
X, Y, Z	mm	0.0001	Linear scales
A, B	deg.	0.0001	

(1): In case of wheel changer -15°/+180°

CAPACITES		
Axe A		SA 50
Electrospindle taper		HSK E50
Electrospindle power	Kw	13.5 (S1)
Electrospindle speed	Rpm	24000
Max. tool diameter	mm	~320
Max. tool length	mm	1700
Workhead center height	mm	220
Max. grinding wheel diameter	mm	300
Max. weight between center	kg	~300

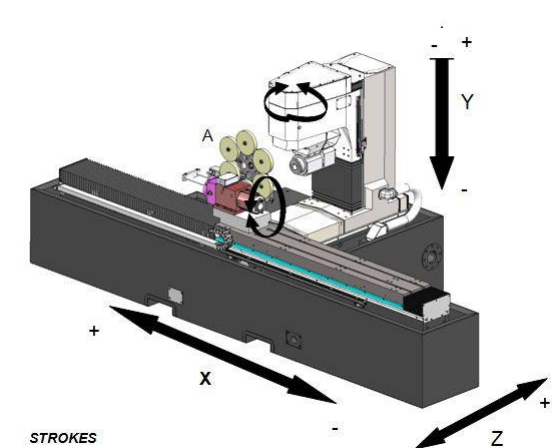



01/03/2020

Page 3/10

BASE HIGH RIGIDITY MINERAL CASTING EPUCRET

FOR ABSORBING VIBRATIONS :

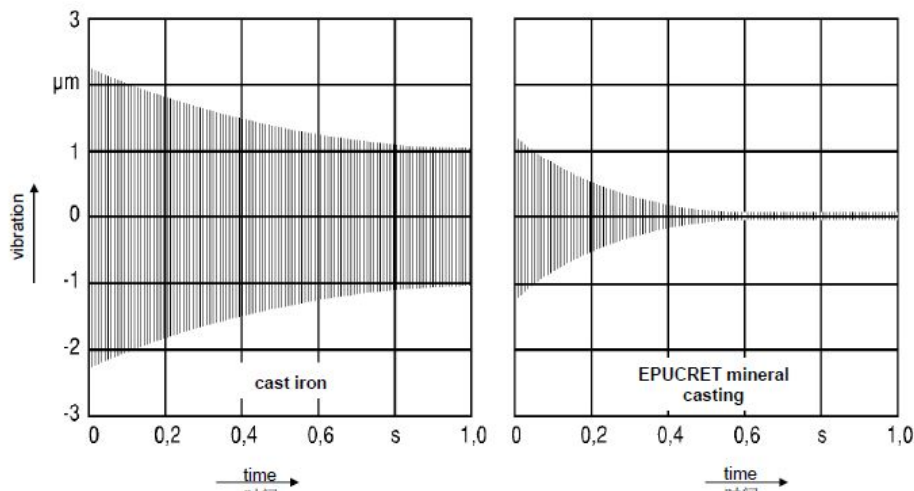

Dimensions : 4334x2205xH2360

Constant power electro spindle HSKE50

- Electro – spindle driven by brush-less motor to enhance surface finishes
- Max speed up to 24 000 rpm for working with small grinding wheels
- Ceramic bearings
- Separated cooling system
- Automatic clamping-unclamping (HSKE50 wheel hub attachment)
- POWER : 13 kw





01/03/2020

Page 4/10

❑ HIGH TORQUE work piece spindle

- Rotation by direct drive. Encoder in the axe.(650 Rpm possible)
- High Torque : 138 Nm
- **Mechanical** clamping and unclamping



❑ Probing system

- A REINSHAW probe fitted onto the machine head, measures parameters like diameters, lengths, helix angles, etc.

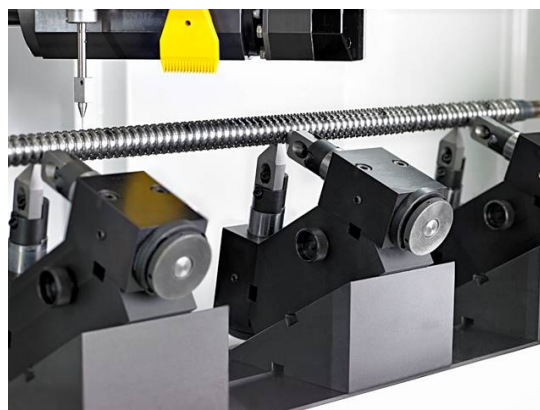

122, rue Pasteur - 69780 TOUSSIEU (France)

Tél. : +33 (0)4 72 15 51 70 - fax : +33 (0)4 72 15 51 71
www.smp.fr - smp@smp.fr

centres d'affûtage - plateaux diviseurs CN - sous-traitance de technologie et ingénierie
tools cutter grinders - NC rotary tables - hightech subcontracting & engineering



01/03/2020

Page 5/10

❑ Lubrication with rigid nozzles:

Watering is a key point of grinding operations to achieve high quality results.

We have opted for rigid nozzles to guarantee flow rate and an oil speed impact at the working point of the wheel faster than the tangential speed of the wheel (to penetrate through the film of air around the wheel).

Efficiency has been dramatically increased despite a same outlet pressure pump.



❑ Oil-vapour suction demister

The suction of the oil-vapour is made through an electrostatic suction construction. The filter is inexhaustible, capacity: 1300 m3/h.

❑ Auto extinguisher fire system

122, rue Pasteur - 69780 TOUSSIEU (France)

Tél. : +33 (0)4 72 15 51 70 - fax : +33 (0)4 72 15 51 71
www.smp.fr - smp@smp.fr

centres d'affûtage - plateaux diviseurs CN - sous-traitance de technologie et ingénierie
tools cutter grinders - NC rotary tables - hightech subcontracting & engineering



01/03/2020

Page 6/10

❑ Programming through a separated computer

This software is installed on the PC, which is connected to the CN (but it could be connected as well with a pre-adjuster bench).

❑ Possibilities of Software : EASY GRIND FULL OPTIONS – VERSION 2017

This Software is delivered without any options and allow you the sharpening or manufacturing of a wide range of tools :

- Cylindrical broaches straight and helicoidal
- Christmas tree broach
- Flat broaches (1 side/2 sides and 3 sides)
- Concave broach
- Fellows cutter
- Gear Hobes
- End mills
- Saw end mills
- Shaped end mills/ conical / with helix / variable helix / with or without radius..
- 3 sides end mill
- Drills (standard, Sumitomo, Hertel, Hosoi...)
- Centre drills/ step drills
- Reamers standard or with steps
- Taps
- Blades
- ..

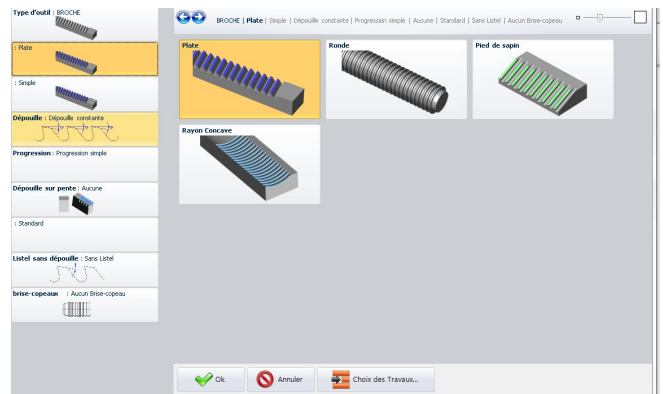



01/03/2020

Page 7/10

❑ 3D Simulation software – VERSION 2017:

Thanks to the 3 D simulation, you can see the grinding process. The software simulate the ISO code. You can also take any measurement you want on the tool.

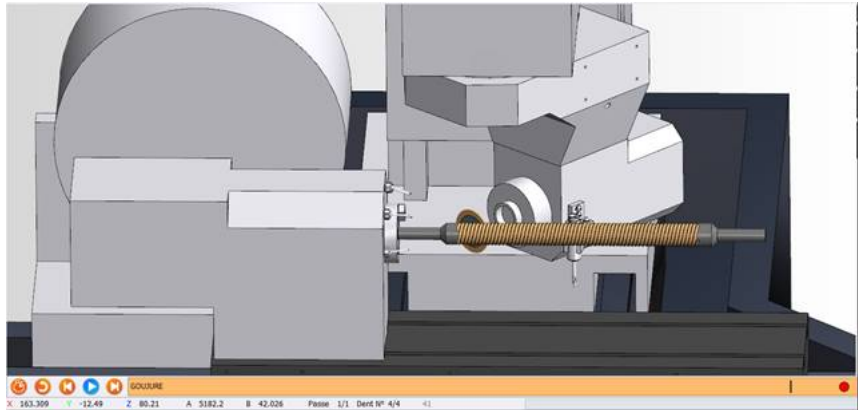

❑ 2D CAD software - XCAP

You can draw many shapes in the Numaffut+, and to compile yours DXF files before sending towards Numaffut+.

122, rue Pasteur - 69780 TOUSSIEU (France)

Tél. : +33 (0)4 72 15 51 70 - fax : +33 (0)4 72 15 51 71
www.smp.fr - smp@smp.fr

centres d'affûtage - plateaux diviseurs CN - sous-traitance de technologie et ingénierie
tools cutter grinders - NC rotary tables - hightech subcontracting & engineering



01/03/2020

Page 8/10

ACCESSORIES WITH CA7 112

Tail stock

We propose you :

- Manual tailstock

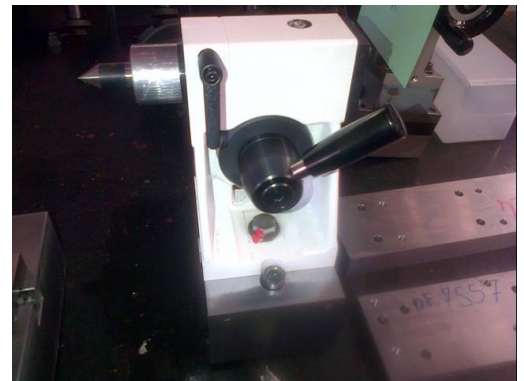

Driving system for small cylindrical broach with adaptor SA50

We provide :

- Point on SA50 chuck
- Holder for broach from D4 until D12



Driving system for cylindrical broach with adaptor SA50 until D60

We provide :

- Point on SA50 chuck
- Holder for broach from D12 until D60

Automatic wheel changer 6 stations

Allow the automatic wheel changing until D 175mm

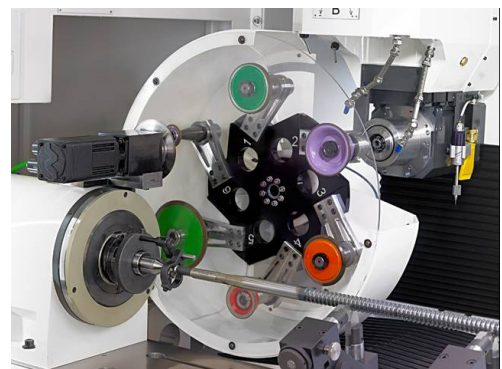

122, rue Pasteur - 69780 TOUSSIEU (France)

Tél. : +33 (0)4 72 15 51 70 - fax : +33 (0)4 72 15 51 71
www.smp.fr - smp@smp.fr

centres d'affûtage - plateaux diviseurs CN - sous-traitance de technologie et ingénierie
tools cutter grinders - NC rotary tables - hightech subcontracting & engineering



❑ Grinding wheel holder

- 1 wheel holders conical with D10 Length 110mm
For grinding cutting face
- 2 wheel holders cylindrical Length 68mm
- 4 wheel holder cylindrical Length 90

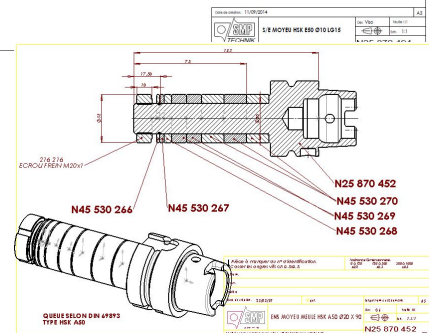
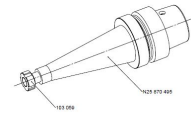

❑ Oil filtering system with cooling unit

Capacity : 700 L.

Dimensions:

800 x 2300 x 400 (H)

Tank is splitted into 2 parts :
Clean and dirty parts

Thickness : 3 mm with special interal treatment.
External painting : EPOXY

4 cardruges : Filtration rate 5 microns.
Possible material filtered : HSS or Carbide.
The system allows maximal flow rate with low oil heating





01/03/2020

Page 10/10

Automatic wheel shaping system

In order to shape the white wheel automatic through software.
The diamond wheel is not included

