

# SUMAB

Scandinavian & UK Machines AB

Foundation of your success!



# CONCRETE TECHNOLOGIES



The Swedish company **SUMAB** (Scandinavian & UK Machines AB) provides a full-service package for delivery of mobile and stationary concrete plants, equipment for production of blocks, borders, paving slabs, wall panels, plants for production of cold asphalt, equipment for loading and packing of cement.

The company was founded in 2003 and it is a reliable partner on the market. The head office is in Malmo, Sweden. There are also representations in Russia and the Baltic States. **SUMAB** delivers its equipment to 55 countries and actively works at the markets of Western Europe, the CIS, America, Africa, and Middle East countries.



## PRODUCTION

- "turnkey" delivery of the mobile and stationary concrete plants various capacity
- "turnkey" delivery of production lines for blocks, borders, stone blocks with various fillers, concrete pipes and rings
- "turnkey" delivery of production lines for the production of internal and external wall panels
- supply of equipment for packing, loading of cement from trucks, ships
- "turnkey" delivery of cement silos and cement terminals
- delivery of laboratories for testing the quality of concrete and asphalt
- restoration and sale of the used mobile concrete plants, maintenance
- delivery of steam generators and diesel generators for the concrete plants
- delivery of the mobile plants for production of cold asphalt.

## SERVICE

The Company provides a full range of services such as:

- consultation concerning the business plan
- help in delivery and customs clearance
- development of the technical documentation, drawings, schemes, layouts
- installation and commissioning, training of personnel, support in the organizing of sales department
- delivery of spare parts.

Our experience includes many projects in Scandinavia, Europe, the Baltic States, the CIS, South America, and many African countries.

**SUMAB**  
Scandinavian & UK Machines AB

### Bolagsverket

Swedish Companies Registration Office  
SE-851 81 Sundsvall, Sweden • Västra Söndervägen 21  
Tel: +46 (0)771-670 670  
bolagsverket@bolagsverket.se • www.bolagsverket.se



#### Certificate of Good Standing

I, Christina Andersson, of Bolagsverket (the Swedish Companies Registration Office) do hereby certify that

**Scandinavian & UK Machines AB**  
registration number: 556650-0277

is a duly incorporated company under the laws of Sweden and is in good standing and has a legal corporate existence as far as the records of this office show as of the date stated below.

In testimony hereof, I have hereunto set my hand and the official seal of Bolagsverket at Sundsvall, this 19<sup>th</sup> day of November in the year of two thousand and eighteen.

*Christina Andersson*  
Christina Andersson



Bolagsverket (the Swedish Companies Registration Office) is the official registrar of limited companies and other forms of business enterprise in Sweden. Before a Certificate of Good Standing is issued, the records kept by this office are examined to ensure that the following requirements are fulfilled for the company in question:

- the company has a registered competent board of directors
- the company has a registered qualified auditor, if required
- the company has fulfilled its obligations regarding the correct filing of its annual report
- the company is not the subject of company division, winding up or bankruptcy proceedings
- the company has not been dissolved as the result of a merger and has not been struck off the register for any other reason

The Certificate is signed by an official authorized to issue these and similar documents on behalf of Bolagsverket.



## CONCRETE BATCHING AND MIXING PLANTS MANUFACTURED BY SCANDINAVIAN TECHNOLOGY.

A concrete plant is intended for the preparation of high-quality concrete mixes of various types and brands of concrete, which is used in a house building construction and in the production of building materials.

All concrete plants can produce all brands of concrete used in the construction industry. Depending on the model of the concrete plant it is capable to produce from 25 to 1000 various types and brands of concrete.

The concrete plant recompenses very quickly itself and begins to make a profit that allows organizing own business almost from zero.

We offer concrete plants of Scandinavian quality, which have proved for decades. Our plants are still in use after 30-40 years of work!

### MOBILE CONCRETE PLANTS SUMAB

**We offer the mobile and semi-mobile concrete plants, mixing plants with design type on wheels and on a container frame.**

- Our plants do not require any permission and foundation. The mobile concrete plant can be installed on any flat platform.
- We guarantee production of concrete in 3 hours after delivery to the job site.
- Our mobile plants are ideal for work in remote areas, where there is no infrastructure only electric power (diesel generator), inert materials and cement.
- The system of automatic control of the Siemens plant allows operating the concrete plant by one person.
- SUMAB has more than 40 years of experience of production of the concrete plants of European quality.

- **Guarantee term is 24 months.**
- **EU standard.**

**The mobile concrete plants recompense very quickly. It is a favorable investment of money.**

**All wearing parts are produced of strong materials and can be replaced separately, that significantly reduces production expenses. There is free access to all units that simplifies its daily service and cleaning.**

**SUMAB**  
Scandinavian & UK Machines AB



**Model SUMAB MINI**

Capacity is 5-9 m<sup>3</sup> per hour  
The design of the plant is executed on a container frame  
2 aggregate storages, mixer is 500/300 l.  
Capacity of water tank is 200 l.  
Automatic control of the plant: computer (20 types of concrete)



**Model SUMAB C 15-1200**

Designed on the container frame. 15-20 m<sup>3</sup>/hour capacity.  
The built-in bunker for filling (2 types) is made from solid forged steel with the strengthened hooks.  
The volume of the inert materials bunker is 2x2,4 m<sup>3</sup>.  
2 separate belt conveyors for the dosing.  
Pan-mixer has the volume of 1200/800 l. The computer Siemens saves 25 concrete recipes. Accuracy of dosing +/-1-2%.  
High pressure cleaner 160 BAR is for the cleaning of the concrete plant.



**Model SUMAB K-30**

Capacity is 25-30 m<sup>3</sup> per hour. On a container frame.  
4 aggregate storages 2,4 m<sup>3</sup> each (with a possibility of increase up to 3,9 m<sup>3</sup>).  
Pan-mixer 1200/800 l is covered with 12 mm layer of high-strength steel Hardox 400. The plant is equipped with a control cabinet. The keyboard of manual control is provided.  
The modern computer system Siemens is capable to release 100 recipes and types of concrete. The printer allows printing each mix of ready batch in kg and % per batch, hour, shift, month.



**Model SUMAB LT-1200**

Capacity is 20-40 m<sup>3</sup> per hour.  
It is mounted on the chassis with wheels.  
There are 4 aggregate storages 2,4 m<sup>3</sup> each with a possibility of increase in sides. The mixer 1200/800 l. covered with 12 mm layer of special high-strength steel Hardox 400.  
Galvanized water tank with the capacity of 250l.  
Completely automatic control Siemens (100 types of concrete).



**Model SUMAB K-40**

The design of the plant is executed on a container frame.  
Capacity is 30-40 m<sup>3</sup> per one hour. There are 4 hoppers.  
The mixer 1500/1000 l. covered with 12 mm layer of special steel. The plant is equipped with a control cabinet. The keyboard of manual control is provided.  
The modern computer system Siemens is capable to release 100 recipes and types of concrete. The printer allows printing each mix of the ready batch.



**Model SUMAB LT-1800**

Capacity is 40-60 m<sup>3</sup> per hour.  
The plant is mounted on the chassis with wheels.  
4 aggregate storages 2,4 m<sup>3</sup> each with a possibility of increase sides up to 3,9 m<sup>3</sup>, the pan-mixer of 1800/1200 liters, is covered with 12 mm a layer of high-strength Hardox 400 steel.  
Sensors of weighing control Siemens are located under the pan-mixer.  
There is a galvanized water tank for 350 liters.  
Completely automatic control Siemens (100 types of concrete).



**Model SUMAB K-60**

Semi-mobile concrete plant, which is designed on a container frame.  
Capacity is 50-60 m<sup>3</sup> per hour. There are 4 aggregate storages 3,8 m<sup>3</sup> each one. Mixer 1800/1200l. Automatically opening gate for supply of ready concrete.  
There is a galvanized water tank for 500 liters with the built-in pump DANFOSS for water dosing.  
The plant is equipped with a control cabinet. The modern computer system Siemens is capable to release 100 recipes and types of concrete.



**Model SUMAB K-80**

Semi-mobile concrete plant, which is designed on a container frame.  
Capacity is 70-80 m<sup>3</sup> per hour. There are 4 aggregate storages 3,8 m<sup>3</sup> each one.  
Mixer 2200/1450 l. Chemical additives pump with a computer-controlled hose. The plant is equipped with a control cabin.  
Computer system Siemens for automatic control of the plant. The display allows to monitor all mixing process.

**SUMAB**  
Scandinavian & UK Machines AB

## STATIONARY CONCRETE PLANTS SUMAB

**Stationary concrete plant SUMAB is the optimal balance between price and quality of the produced concrete.**

**The concrete plants Sumab are assembled from the components of the leading European suppliers such as:**

- Sicoma Turbo mixer (Italy)
- Pneumatic gates for opening of warehouses of inert materials (Italy)
- Computer Siemens (Germany)
- Automation ABB (Sweden)
- Various forms of dosing (Germany).

- **EU standard**
- **Warranty 24 months.**



**Model SUMAB T-15**

Capacity is 15 m<sup>3</sup> per hour.  
3 aggregate storages 8 m<sup>3</sup> each one equipped with pneumatic gates. The planetary mixer 500/330 liters with skip feeding Sicoma (Italy), the conveyor of feeding of inert materials with sensors from Siemens.  
Cement scale (200 kg), chemical additives pump, automatic control system of the plant operation, computer Siemens (Germany).  
Control cabinet.



**Model SUMAB T-30**

Capacity is 30 m<sup>3</sup> per hour.  
There are 2 aggregate storages 10 m<sup>3</sup> each one with pneumatic control gates.  
The planetary mixer 1125/750 liters with skip feeding Sicoma (Italy), the conveyor of inert materials feeding, sensors Siemens, chemical additives pump, cement scale (300 kg).  
Automatic control system of the plant operation, computer Siemens (100 types of concrete), control cabinet.



**Model SUMAB T-40**

Stationary concrete plant.  
Capacity is 30-40 m<sup>3</sup> per hour. There are 3 aggregate storages 20 m<sup>3</sup> each one with pneumatic control gates.  
The planetary mixer 1125/750 liters with skip feeding Sicoma (Italy).  
Conveyor of inert materials feeding, sensors Siemens, chemical additives pump, an automatic control system of the Siemens plant operation, the control cabinet.  
Air compressor 270 l.



**Model SUMAB T-60**

Stationary concrete mixing plant. Capacity is 60-70 m<sup>3</sup>/h, 3 aggregate storages 30 m<sup>3</sup> each one with pneumatic control gates. There is a planetary two-shaft mixer, skip is 1875/1250 liters Sicoma Turbo (Italy). There are 2 chemical additives pumps, automation ABB (Sweden), computer program Siemens (Germany), control cabinet, system of feeding Sumab (Sweden).



**Model SUMAB T-80**

Stationary concrete mixing plant. Capacity is 80-100 m<sup>3</sup> per hour. There are 6 aggregate storages 20 m<sup>3</sup> each one with pneumatic control gates. There is a planetary twin-shaft mixer 3000/2000 l. Sicoma (Italy). Skip for loading of inert materials to the mixer 3 m<sup>3</sup>. Weight batcher of cement with capacity of 800 kg. The additional batcher for 2 liquid chemical additives with total capacity of 35 kg. Computer program Siemens (Germany), control cabinet.



**Model SUMAB T-100**

Stationary concrete mixing plant. Capacity is 90-100 m<sup>3</sup>/hour. 4 aggregate storages 20 m<sup>3</sup> each one. There is twin-shaft horizontal mixer 3000/2000 liters with Sicoma skip. Cement scale 1300 kg, water tank 700 l, 2 chemical additive pumps 25 kg. Automatic control Siemens (1000 types of concrete), the printer allows to print each mix of ready batch in kg and %, indicators for batch, hour, shift, month. There is a control cabinet from insulating panels 2,4x5m (summer or four season's version execution).



**Model SUMAB T-120**

Stationary concrete plant. Capacity is 120 m<sup>3</sup> per hour. There are 4 aggregate storages 25 m<sup>3</sup> each one with pneumatic control gates. There are planetary twin-shaft mixer 4500/3000 l. Sicoma (Italy), bunker of weighing of inert materials 5 m<sup>3</sup>, the cement scale with capacity of 1200 kg with weight cameras and the computer, the control panel with PLC control system Siemens, which is adapted for quickly installation (saves 200 types of concrete). There is a control cabinet from insulating panels 2,4x5m (summer or four season's version execution).

**SUMAB**  
Scandinavian & UK Machines AB

**PRE-FABRICATED CONCRETE PLANTS SUMAB LUX CLASS**

- Minimum foundation works
- An opportunity to move the plant from one working platform on another one
- Low costs of service
- The built-in cabin allows saving space
- Fast installation on the platform
- Simple and economical transportation
- **EU standard**



**Model SUMAB F-60**

Sumab F-60 is the mobile plant intended for satisfaction of the growing need for reduction of time at installation on the building site. The mobile plant is ideal for construction companies, which need high-performance installation and excellent qualitative characteristics of concrete. The plant consists of two modules: the block of inert materials and the mixing block previously collected and equipped with electrical wiring that allows transferring the plant from transport position to working position within a short period.



**Model SUMAB F-100**

Sumab F-100 is the mobile installation, which is developed for satisfaction of the growing need for reduction of time at installation on the building site. The plant consists of the modular elements, which are completely mounted and equipped with electrical wiring that allows transferring the plant from transport to working position within a short period. The main structure is mounted on a steel frame, which is the base. The retaining wall of stage (option) fastens on hinges. It is completely closed during transportation, allows building quickly set stage for loading of inert materials.

The whole installation is transported on three semi-trailers, two of which are low-frame. Additional transport units are necessary for transportation of silos, additional components and accessories.



**Model SUMAB F-130**

The structure of the Sumab F-130 plant allows transporting it without special permissions, also to make installation in the shortest time. It is transported on three semi-trailers, two of which are low-frame (silos and additional options require additional transport). The plant can guarantee productivity of 130 m<sup>3</sup>/hour of high-quality concrete. It is equipped with the isolating covering of the mixing block and loading conveyor. The special design, modularity of mixing unit and the block of the loading conveyor allow setting them even together with already existing aggregate storages.

## THE MOBILE PLANTS FOR PRODUCTION OF COLD ASPHALT

Cold asphalt is a traditional asphalt prepared according to special cured technology with use of the modified bitumen.

Feature of cold asphalt is that it can be in a friable state a long time in dependence of method of storage, temperature of storage and composition of mix.

Also there is no need to do preliminary preparation before use. It is possible to apply cold asphalt at the subzero air temperature.

The SUMAB Company offers the mobile plants for production of cold asphalt of the SUMAB ES series:

- Capacity starts from 5 up to 80 m<sup>3</sup> of cold asphalt per hour.
- 2-4 aggregate storages.
- Weight sensors of inert materials. Location is under the mixer. Feeding accuracy +/- 1-2 %. SIEMENS.
- The pan-mixer is covered with 12 mm layer of special steel. There are 5 quick-detachable blades with fibro plastic tips.
- Control panel of the mobile plant. Keyboard for manual control. The touch screen, the computer Siemens for automatic control of the plant.
- Chemical additives pump for production of cold asphalt.
- High pressure cleaner for cleaning of the plant.

The mobile plants of the SUMAB ES series can produce cold asphalt and concrete at the same time, which is a good idea for the road building companies or the companies planning to expand types of their production.



## EQUIPMENT FOR PRODUCTION OF BLOCKS, BORDERS, PAVING STONES AND OTHER CONCRETE PRODUCTS

### STATIONARY CONCRETE BLOCK MAKING MACHINES SUMAB R-1500, SUMAB R-1000, SUMAB R-500, SUMAB R-400, SUMAB R-300L AND SUMAB R-300

Stationary vibrating presses and block lines **SUMAB** are used for the production of concrete blocks, borders, stone blocks, etc. (more than 50 names of products with various fillers).

- "turnkey" plants with capacity from 475 up to 2875 blocks per hour
- semi-automatic and full automatic production
- separate delivery of machines, vibrating presses or plants as a set "turnkey"
- delivery of different types of drying/curing systems
- additional options: elevators, lovertors, conveyor belt, equipment for the loading of finished products, control system, concrete units, packing machines, etc.
- moulds for each type of production
- special wooden pallets
- special equipment such as: face mix device (color, a firm surface, combinations of different colors and/or mixes)
- vibration system Knauer, Germany

- **EU standard**
- **24 months warranty.**



**SUMAB R-1500**

The stationary block machine SUMAB R-1500

Production capacity per shift (8 h):

Paving stone (10x20x6 cm) - 2000-2600 m<sup>2</sup>

Hollow block (20x20x40 cm) - 23000 pieces

Curbstone - 2800-4000 pieces (depending on the sizes of curbstones, without or with face mix)

Pallet size max.: 1400x1100 mm

Useful area max.: 1300x1050 mm



**SUMAB R-1000**

The stationary block machine SUMAB R-1000

Production capacity per shift (8 h):

Paving stone (10x20x6 cm) - 1360-1680 m<sup>2</sup>

Hollow block (20x20x40 cm) - 17280 pieces.

Curbstone - 2400-2800 pieces (depending on the sizes of curbstones, without or with face mix)

Pallet size max.: 1400x950 mm

Useful area max.: 1300x900 mm



**SUMAB R-500**

The stationary block machine SUMAB R-500  
Production capacity per shift (8 h):  
Paving stone (10x20x6 cm) - 864 m<sup>2</sup> (with face mix)  
1016 m<sup>2</sup> (without face mix)  
Hollow block (20x20x40 cm) - 12960 pieces  
Dimensions of pallet: 1400x700 mm  
Working area max.: 1250x650 mm



**SUMAB R-400**

The stationary block machine SUMAB R-400  
Production capacity per shift (8 h):  
Paving stone (10x20x6 cm) - 550-640 m<sup>2</sup>  
Hollow block (20x20x40 cm) - 6912 pieces  
Curbstone - 1600-2000 pieces (depending on the sizes of curbstones, without or with face mix)  
Dimensions of the pallet max.: 1200x550 mm  
Useful area max.: 1100x500 mm



**SUMAB R-300L**

The stationary block machine SUMAB R-300L  
Production capacity per shift (8 h):  
Paving stone (10x20x6 cm) - 450 m<sup>2</sup> (with face mix)  
500 m<sup>2</sup> (without face mix)  
Hollow block (20x20x40 cm) - 4800 pieces  
Pallet dimensions: 1200x550 mm  
Working area max.: 1000x500 mm



**SUMAB R-300**

The stationary block machine SUMAB R-300  
Production capacity per shift (8 h):  
Paving stone (10x20x6 cm) - 360 m<sup>2</sup> (with face mix)  
400 m<sup>2</sup> (without face mix)  
Hollow block (20x20x40 cm) - 3800 pieces  
Pallet dimensions: 1000x550 mm  
Working area max.: 800x500 mm

**ADDITIONAL OPTIONS FOR STATIONARY BLOCK MACHINES SUMAB**



Facemix equipment for products with second layer



Pallet insert device with pallet magazine with soft start/stop and speed regulation



Multicolor or Color mix device allowing to produce a face layer of products with different colors or combinations of mixes



Pneumatic mould clamping



Equipment for decorative processing of surface of concrete products (paving stones, pedestrian blocks, etc.) with water supply under high pressure



Rotating brush for cleaning fresh products surface



Device for spraying of working pallets



Tamber head vibration



Transport of fresh concrete blocks from the machine with speed/start stop ramp regulation, consists of two chain transport systems



Elevator is an automatic device for accepting and raising pallets with fresh pieces – robot for putting pallets with fresh products into the curing rack (with 6-12 levels for blocks or the 2x 6-12 levels for paving stones)

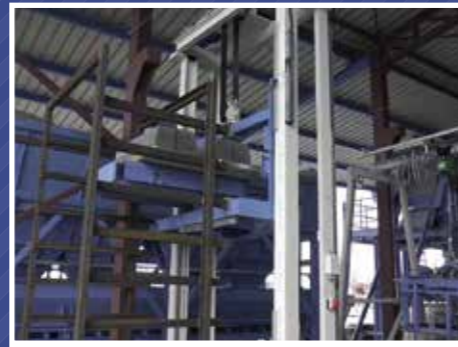

Loverator is an automatic device - robot for accepting pallets with dry products from racks and lowering to transport conveyor to cubing position (with 6-12 levels for blocks or 2x 6-12 levels for paving stones)



Splitter is a device for production of splitter blocks



Automatic finger-system – automatic robot-machine to move fresh products after vibropressing from elevator in the drying chamber and back to loverator



Automatic hydraulic Cuber - the equipment for packing concrete products from production boards to transport boards with hydraulic clamp and electrical lifting -moving of clamp mechanism



Pallet rotating device + cross pallet transport back to machine magazine, the pallets will be able to be used on both sides equally



Additional equipment for polystyrene (insulating part of the block)



Automatic control system of the production line and the PC, Siemens computer program. Cables, system fuses, the alarm system security



Control cabin with PC and cables of connection of units and assemblies



Pallet conveyor for transporting pallets with dry products to cubing station and after to pallet rotation - cross transport.

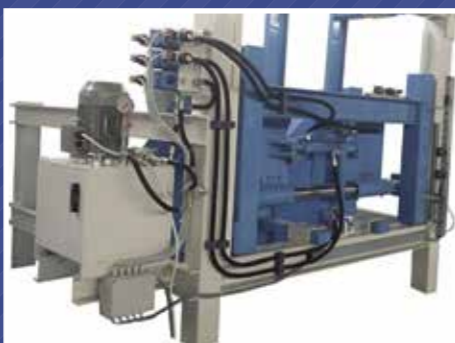

Pallet magazine for euro pallets and automatic lowering to slat conveyor for transporting it to cubing position



Lamellas is a conveyor for moving finished products for packing and moving to the warehouse



System for cleaning of the road borders



Rotating brush for wooden pallets cleaning



Internet modem service hardware for machine's possible adjustments



The packing machine for pallets with finished products



**SUMAB**  
Scandinavian & UK Machines AB

## MOBILE BLOCK MACHINES SUMAB

Production and unloading of concrete products are carried out under the egg-laying method. This way of production is perfectly suitable for regions in which climate conditions allow to carry out drying of the finished products outdoors.

Mobile block lines are successfully used in the African and Arab Middle East countries, the countries of Central Asia and other regions, where the weather is mostly dry. It is possible to produce different types of concrete products: hollow blocks, solid blocks, flues, curbstones, stone blocks, heat-insulating blocks and others by means of mobile vibrating presses **SUMAB**. The flexibility of configuration and a large number of components allows producing modular block lines (as Lego). The **SUMAB E-12** and **SUMAB E-6** models present mobile block machines **SUMAB**.

- EU standard
- 24 months warranty.

### Additional options for Mobile block machines **SUMAB**:

- Face mix device for second concrete layer for paving stones and curbstones
- Vibration plate for producing paving stones on egg-layer machine
- Tank to deliver concrete from the concrete plant to the mobile block machine
- The equipment for collection and overload of finished products (blocks, pavers, curbs)
- Additional equipment for polystyrene (insulating part of the block)
- Cables, moulds, etc.

	SUMAB E-12	SUMAB E-6
Operating mode:	Automatic/semiautomatic	Automatic/semiautomatic
Electricity consumption, max.:	17,5 kW	13 kW
Production capacity per shift (8 h) (20x20x40 cm, hollow blocks):	9600 pcs. of blocks	6900 pcs. of blocks
Mould production area max.:	1240x1130 mm	1240x550 mm
Concrete hopper volume:	1000 l	700 l
Max. block height:	500 mm	350 mm
Min. block height:	175 mm	175 mm
Machine weight with mould:	6650 kg	4200 kg



SUMAB E-6



SUMAB E-12

Block production lines SUMAB can be produced and delivered in various configurations, with different options according to the Customer's request.

Photos of the finished products:



We offer vibration tables for making wall elements of concrete of different configurations. With one table it is possible to produce up to 100 kinds of products.

We can also offer complete HOUSE-BUILDING FACTORIES, which make possible to build all types of houses and buildings with Scandinavian technology.

- Automatic or semi-automatic production lines and house-building equipment
- EU standard.

The tables are made of sturdy steel beams construction covered with a descaled steel plate.

**Life cycle of a vibrotable is up to 30 years long.**

The tables can be equipped with a hydraulic tilting system, built-in heating pipes and vibrators. You can choose any size for the tables depending on which type of panels you need.

**SUMAB** equipment for the production of interior and exterior wall panels includes:

- Different types of circulating vibrating tables and tilting.
- House-Building Factories "turnkey".
- The possibility of full or partial reconstruction of old plants and installation of modern equipment.
- The profitability of production, reduction of economic and production costs.
- The optimum solution to start a high-quality panel construction of modern homes and buildings.

### CIRCULATING TABLES



You can watch the videos of our block lines on our web-sites:  
[www.scand-uk-machines.com](http://www.scand-uk-machines.com), [www.sumab.eu](http://www.sumab.eu)

**SUMAB**  
Scandinavian & UK Machines AB

## TILTING TABLES



## READY PROJECTS OF HOUSES AND BUILDINGS



**For fulfilling of your order and calculating the cost of production we need the following data:**

- Which type of panels are you planning to produce?
- Which are the standards of your country?
- Which are the volumes of producing?
- Which are dimensions of your planned facilities?
- Which type of planned production lines: fully automatic or semi-automatic?
- Do you plan to make the relevant details: wooden frames, metal valves, plastic connectors, etc.?

**SUMAB**  
Scandinavian & UK Machines AB

## CEMENT SILOS AND CEMENT TERMINALS

We offer cement silos of various volumes ranging from 23 up to 1450 m<sup>3</sup>, and with diameter ranging from 2500 up to 9500 mm. Therefore, they are suitable both for small concrete plants, and for big plants. Though they are produced for cement, they are also recommended for storage of other inert materials, such as sand, limestone, ashes, etc.

### Main characteristics:

- Production according to the standards UNI 10011, DIN 1055, DIN 4113
- Standard design for not seismic regions
- Raw materials from soft steel conforms to the UNI 7070-723 standards
- Compliance to the EC standards
- Welding by a continuous seam, tightness
- Standard painting: bead-blasting cleaning, finishing with synthetic enamel on external part of silo.

Panel silos of the SP series are painted as well from the inside. Connections between panels are waterproof. High-quality bolts.

### Additional standard and special options:

- Handrail, ladders with protection
- Rotary gates, safety valves, dispersion units, level indicators
- The cone of unloading 60° (a corner between walls) is available to silos with DN 2500, 3500, 5000, 6150
- Release for seismic regions
- Special color
- Set of filters, etc.

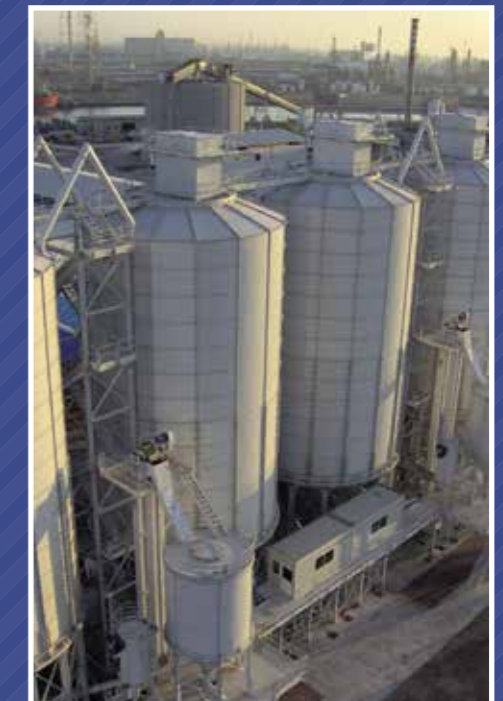

## THE EQUIPMENT FOR THE CEMENT OVERLOAD FROM HOPPER WAGONS, SHIPS TO CEMENT SILOS AND CEMENT TRUCKS

- Provides a full operation cycle of cement, unloading from wagons and loading to silos
- High efficiency even during the faltering works
- Pneumatic equipment
- Screw equipment
- The equipment for cement overload from big-bags to cement silos
- Full compliance to environmental standards
- International standards
  
- **EU standard**
- **24 months warranty.**



## LABORATORIES FOR DETERMINATION OF QUALITY OF CONCRETE, ASPHALT AND REINFORCED CONCRETE PRODUCTS

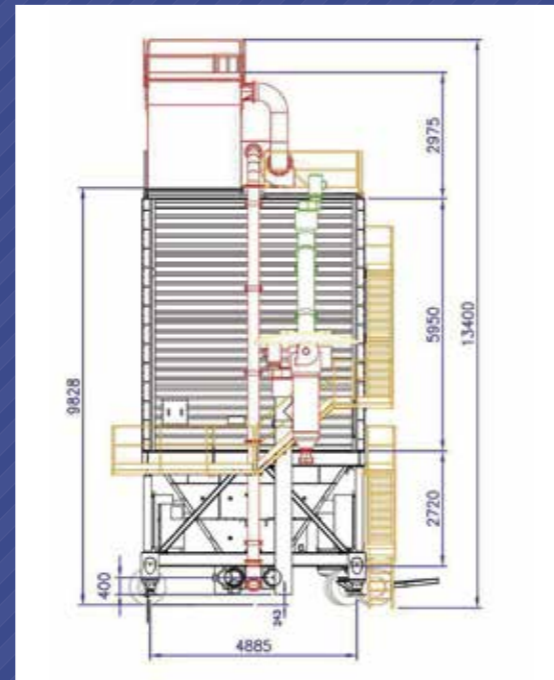
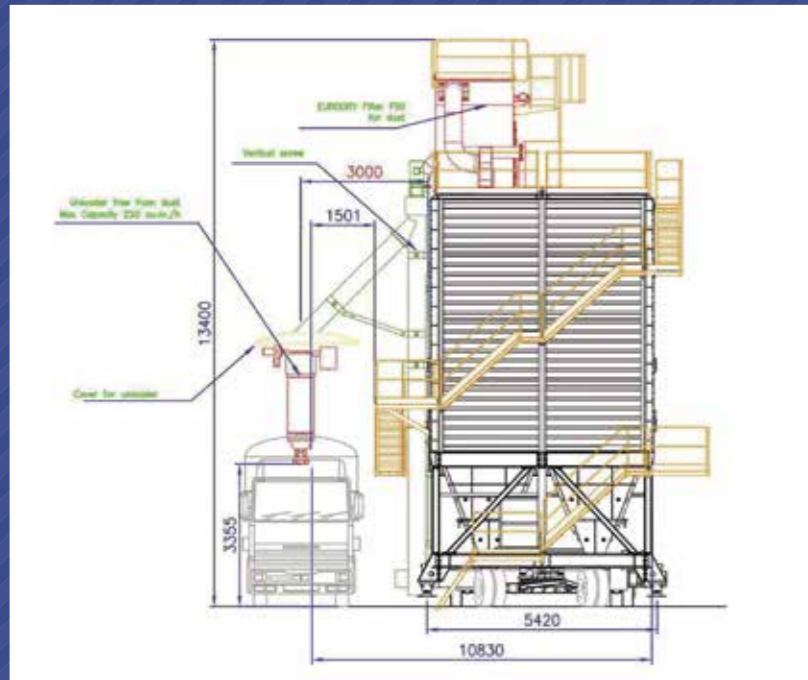

**AT204H**

Consistometer VE-BE. Laboratory for identifying the density and the workability of concrete. Suitable for concrete mixtures with low and very low workability.



**B205X5**

Versatile planetary mixer for asphalt and cement, 5 liters – 6 speeds. Universal model, ideal for special solutions hydraulic lime, cement, soil and asphalt.

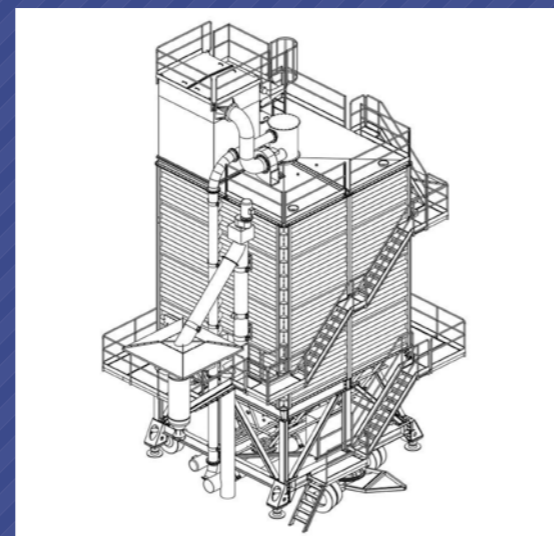
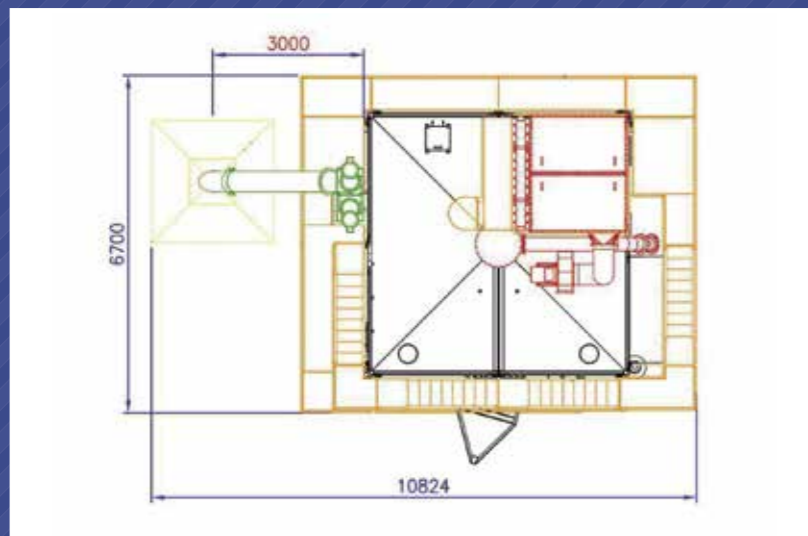

In our assortment there also other types of laboratories used for the determination of the quality and to test the durability and flexibility of concrete, cement, reinforced concrete products, asphalt, etc.

**SUMAB**  
Scandinavian & UK Machines AB

# SUMAB

Scandinavian & UK Machines AB

## Our company participation in the International Trade Fair for Construction Machinery "Bauma" in München, Germany

2007



2010



2013



2016



**Scandinavian & UK Machines AB**  
Reg. No: 556 650-0277  
Address: Bjurögatan 48, Malmö, Sweden

Tel.: +46 4030 6327  
Fax: +46 4030 6327  
Mob.tel.: +46 7 0444 2537, +46 7 039 25753, +7 921 595 6268

e-mail: [office@scand-uk-machines.com](mailto:office@scand-uk-machines.com)  
Web-site: [www.scand-uk-machines.com](http://www.scand-uk-machines.com)  
[www.sumab.eu](http://www.sumab.eu)

**General partner Scandinavian Machines & Partners**