

## Heckert Machining Centers

HEC 500 / HEC 630 / HEC 800 Athletic

HEC 500 X5 / HEC 630 X5 / HEC 800 X5

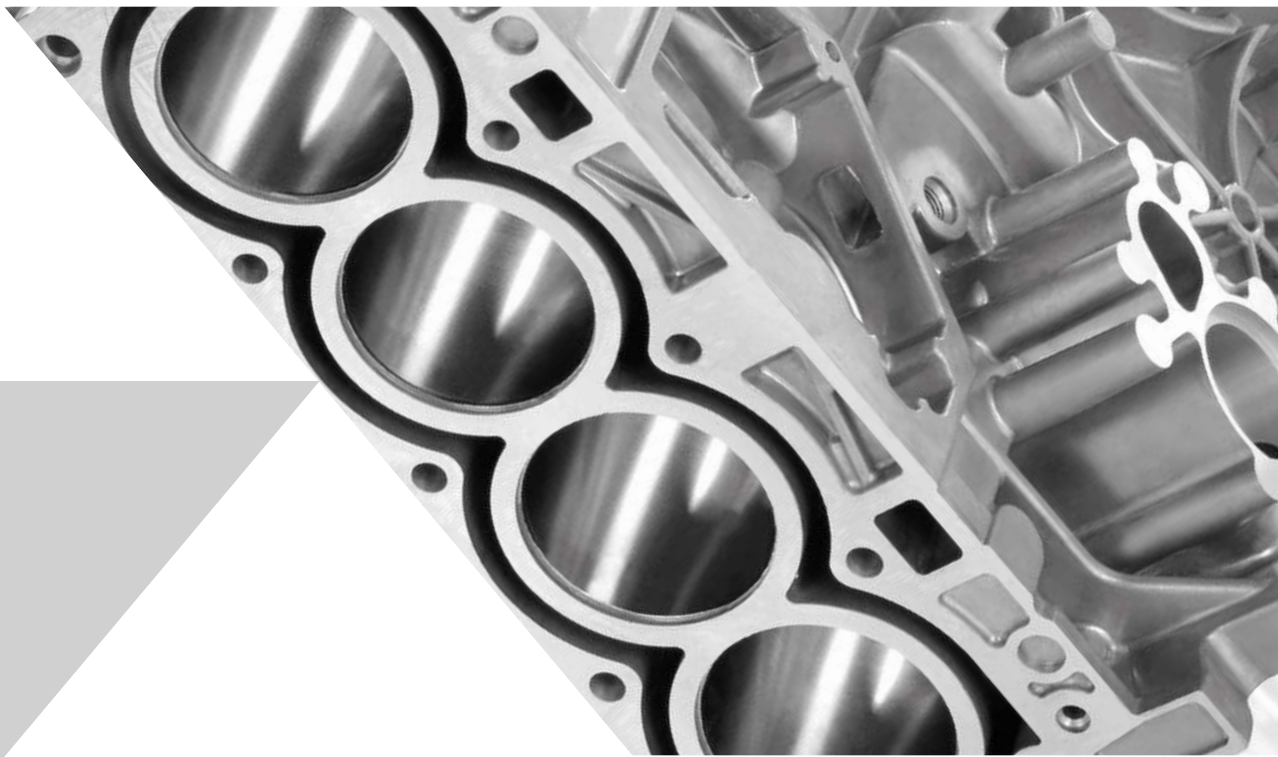

## Flexible production – high efficiency and precision

As all-round machining centers, the 4-/5-axis Horizontal machining centers of the Athletic and X5 series are perfect for a wide field of application in all areas of the metalworking industry.

The modular design of the centers provides an individual production solution. In this regard, the work spindle is available in horizontal design (variable regarding performance and speed) and as adjustable NC quill in order to machine deep surfaces and holes.

With a combined rotary and pivoting unit, the machining centers Heckert HEC 500 X5 / 630 X5 / 800 X5 turn to 5-axis centers. In order to increase the process integration, rotationally symmetric machining such as turning and turn-milling are feasible with the option MT (Multitasking).

With a high-accuracy package as option, the positioning accuracy in the traverse axes is improved. Thus, the quality of the workpiece machining is enhanced.

The high flexibility and productivity, the reduction of the non-productive downtimes and the energy-efficient design of the machining centers ensure the reduction of the production time per work piece and saving of maintenance and operating costs while complying with ecological requirements.

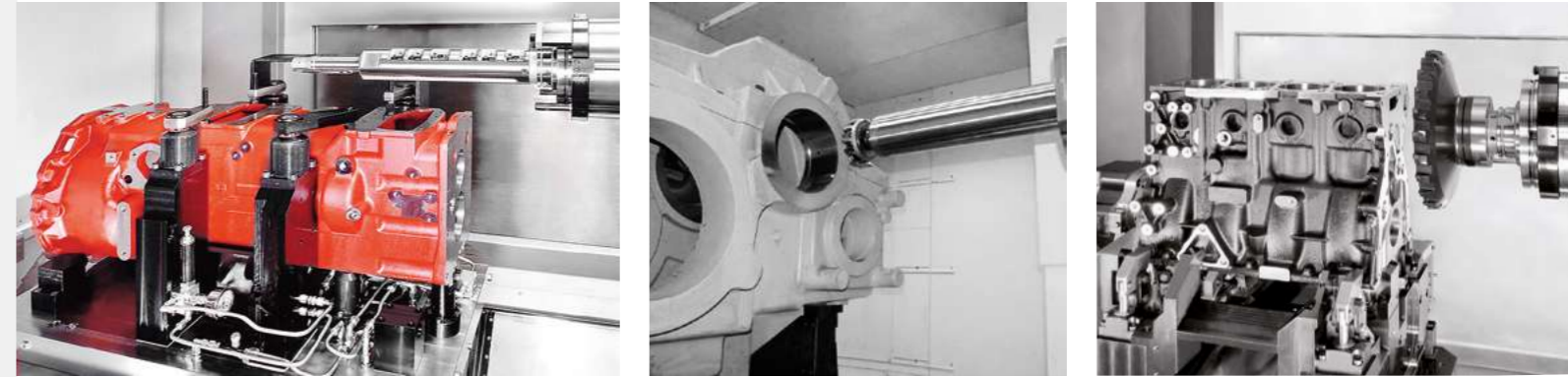

# Innovations for high customer benefit



## High stock removal rate

by powerful gear spindle with AC motor with drive powers up to 82 kW or highly dynamic motor spindle

## Flexibility of the work spindle

- optionally
- Horizontal design with speed up to 15,000 rpm
- NC quill with 500 mm adjustment range

## Machining of large workpieces

by optimum interference diameter and high traverse paths in the linear axes

## High dynamics in the adjustment axes

by digital AC feed drives with rapid traverse up to 65 m/min

## High machining quality and long-term accuracy

by profiled rail guides in all linear axes with preloaded guiding carriage as well as preloaded ball screw drives with counter bearing

## Thermal stability

Thermo-symmetric design and high rigidity (FEM calculation) of the main sub-assemblies machine bed, slide and stand

## Optimum cutting conditions

- Minimum quantity lubrication for dry machining
- Wet machining with coolant supply via nozzles or by the spindle and tool center with a pressure up to 80 bar, task-tailored coolant filtration

## Multi-side machining with precision

NC rotary table with direct drive up to 80 rpm, input resolution 0.001 degrees und reversal error  $U_{max} 2''$

## Complete machining with 5th NC axis

Combined NC rotating and tilting unit in the series HEC 500 X5, HEC 630 X5 and HEC 800 X5

## Turning and turn-milling

Additional package MT (Multitasking) with powerful direct drive for speeds up to 500 rpm in the B-axis

## High-accuracy package (option)

Water cooling and temperature control of important sub-assemblies and the precision production process improve the positioning accuracy of the adjustment axes.

## Fast readiness for operation

Compact machines for complete transport and foundation-free installation

## User-friendly workpiece handling

Rotating load-unload station with  $4 \times 90^\circ$  indexing, coupling device for hydraulic workpiece clamping devices with a maximum of 6 connections

## Safe and quick swarf removal/ protection of the functional elements

The gantry design allows free swarf flow in the centrally arranged swarf conveyor. The formation of swarf clusters in the workspace is prevented. By using fixed plates, the functional elements are perfectly protected against swarf and coolant.

## Low maintenance costs/ reduction of servicing costs

- Long-term grease lubrication for work spindle and table sub-assemblies
- Central lubrication for ball screw drives and profiled rail guides
- Fixed plates instead of telescopic covers
- CMS monitoring for collision detection and damage limitation

## Quick automatic pallet change

with hydraulic lifting/pivoting changer

## Innovative tool handling

- Chain magazines, either for 40, 60 or 120 tools
- Tower magazine with 180 to 450 storage locations

## Highly dynamic tool change

by hydraulic double-arm gripper and spindle-parallel arrangement of the tools in the magazine for low chip-to-chip-times



## Control and monitoring devices

(partly as an option)

- Tool breakage monitoring
- Optical probe and radio touch probe
- Speed monitoring of the tools
- Tool identification
- Adaptive control
- Monitoring of the utilization of the main drive
- Remote diagnosis

## Intelligent service and diagnostic system SAM

Software solutions for improving the machine uptime, reduction of the maintenance costs and quick fault diagnosis

## High energy efficiency

by using high-quality energy-saving components and innovative development concepts

## High ease of use

Ergonomically designed main control panel with 15" TFT color display, noise-absorbing workspace covering, emission extraction from the workspace and workspace flushing

## Unattended production

Concatenation of the machining centers and extension with pallet storage and automatic workpiece transfer to flexible production systems

# Power and dynamics reduce unit costs

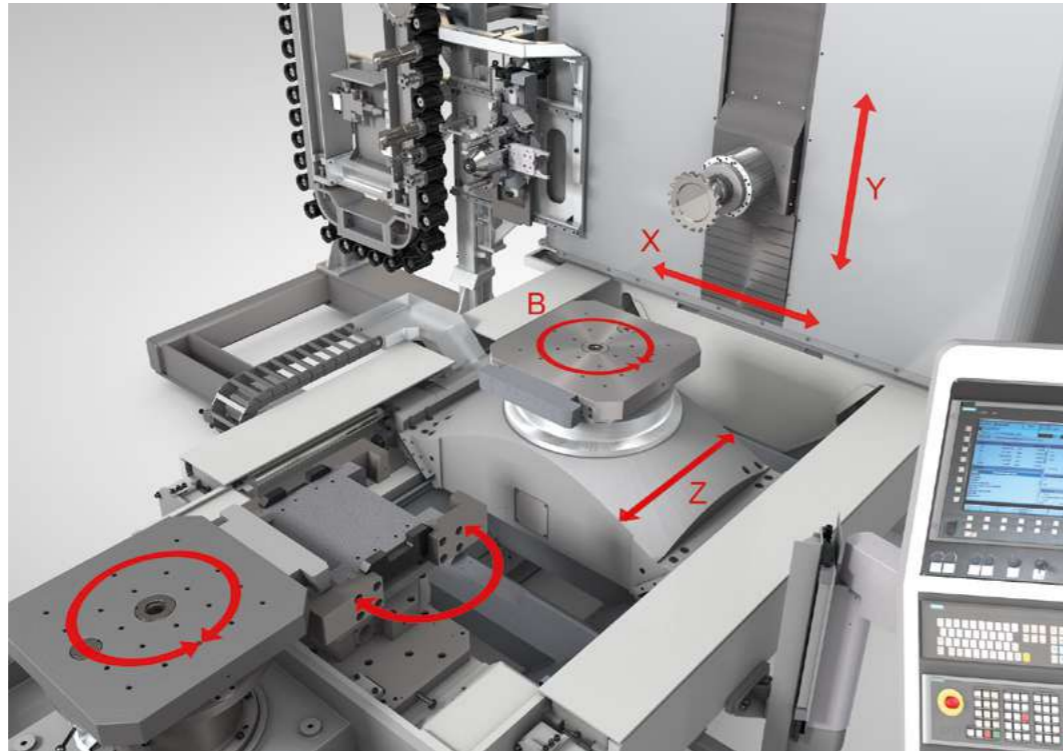

## High stock removal rate

The demand for maximum cutting ability is satisfied by the horizontal work spindle with 2-stage high-precision gearbox and AC main motor (power up to a maximum of 82 kW). Design with motor spindle (speed max. 15,000 rpm) is optionally possible.

The compact, bending- and torsion resistant work spindle with 4-fold bearing guarantees high running smoothness and long-term accuracy. The

work spindle is designed for tools with either hollow-shaft taper HSK-A 100, steep taper SK 50 form AD and AF, BT or CAT-50. The tools are securely clamped and hydraulically released via a disk spring package. The standard includes cleaning the spindle taper with compressed air during the tool change, blowing out of the internal coolant supply of the tools and the electronic spindle adjustment for the oriented spindle stop.

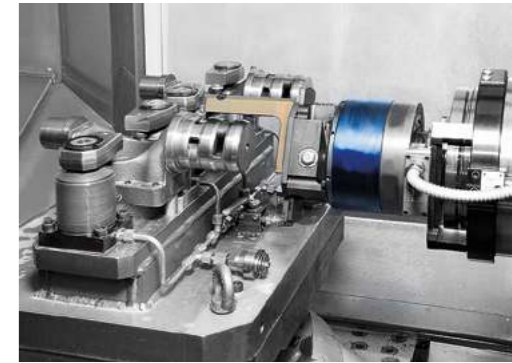

Machining of the crankshaft bearing bore hole to cylindricity 12  $\mu\text{m}$  with 700 mm long boring bar.

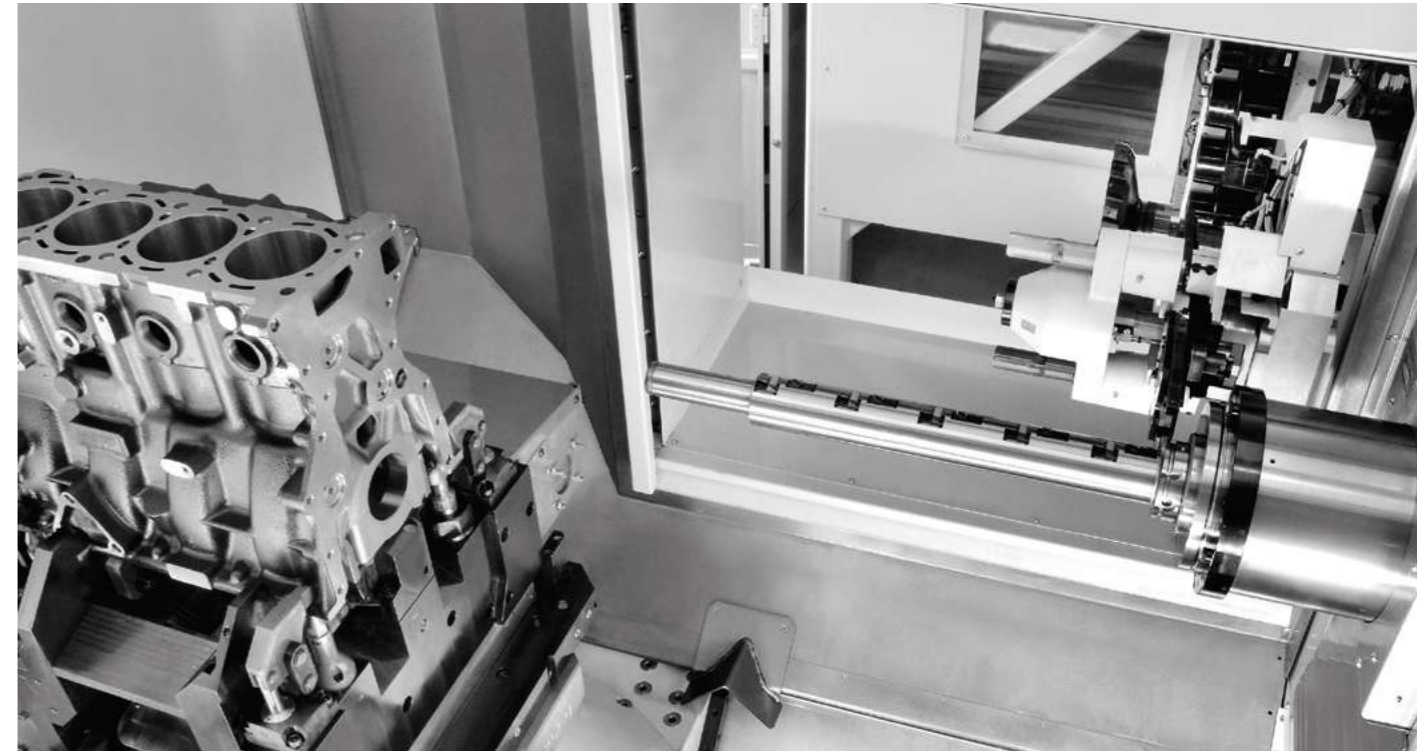

## NC quill

The complete model range is optionally available with a 500 mm adjustable NC quill for machining deep holes and surfaces as well as long tours.

## Optimum swarf removal

As a result of the cross bed principle with traveling column and the integration of all hydraulic and pneumatic power units into the basic machine, a high tightness is achieved and the leakage of media is prevented. Workpiece side and workspace are designed in such a way that a quick and safe swarf removal and coolant disposal is performed.

# Minimum downtimes and high machining accuracy



Machining with 500 mm adjustable NC quill.

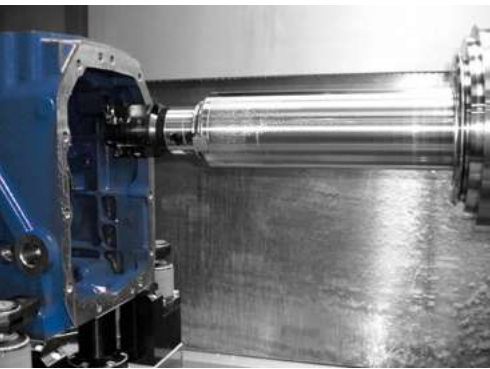

Machining of a crankshaft bore hole with 800 mm long boring bar.

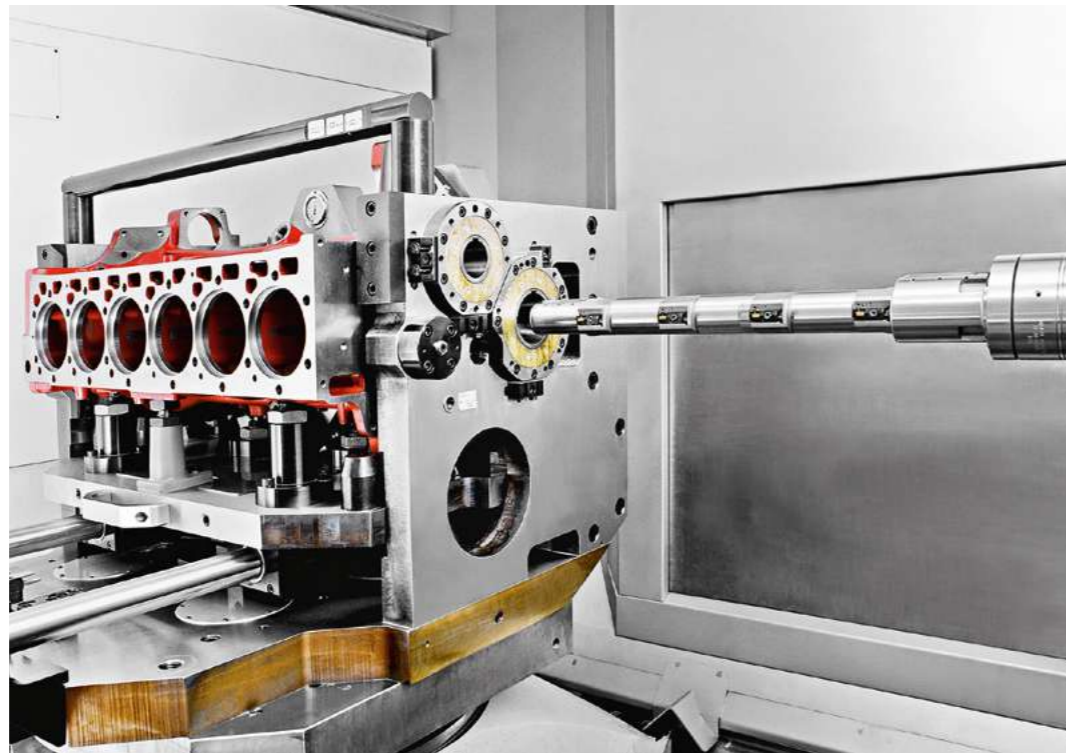

Automatic change of tools up to a diameter of 340 mm, a length up to 800 mm and a weight of max. 50 kg.

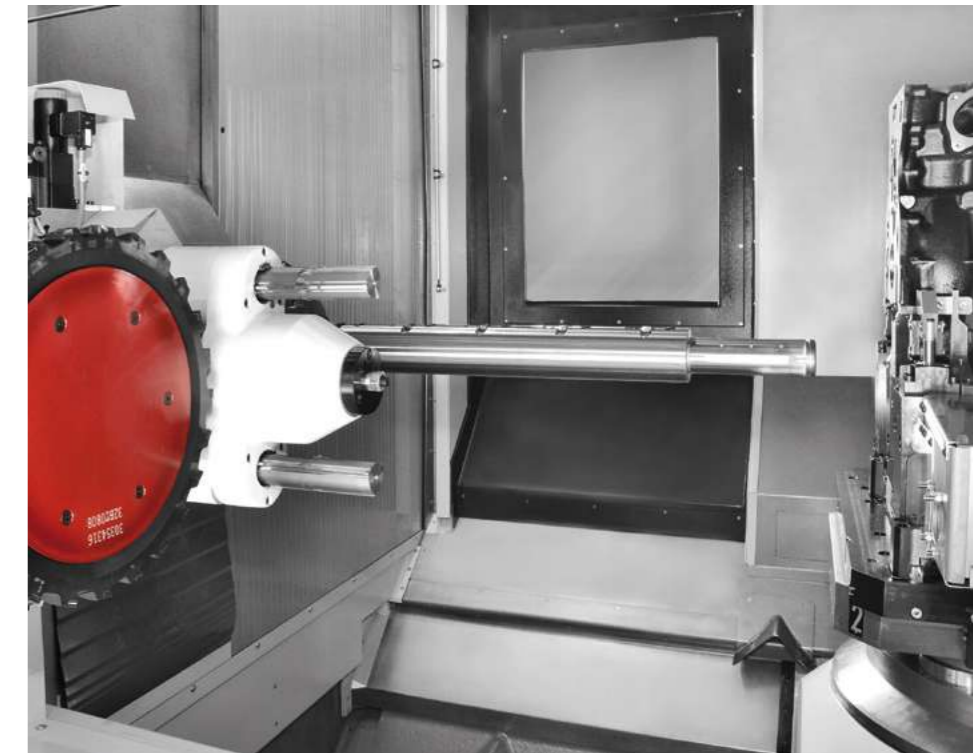

## Dry machining

The swarf conveyor (with a width up to 1,000 mm) arranged centrally under the machine bed ensures a maximum swarf discharge volume within a very short time and thus creates ideal conditions for dry machining.

## High loading mass

The workpiece side in gantry design with two feed drives for the pallet table offers the optimum condition for a high loading mass and high dynamics.

## Optimum conditions for wet machining

The supply of the coolant is performed via adjustable ball nozzles or through the spindle or tool center with a maximum of 80 bar. Depending on the cutting material, various filter systems can be used. Emission extraction from the workspace, splash shower, cover rinsing and workspace rinsing with whirling nozzle are available as option.

## Innovative tool handling

The automatic tool change is optimally designed for reducing the unproductive downtimes. The hydraulic tool double-arm gripper, the spindle-parallel arrangement of the tools in the chain magazine and the optimization of the changing process guarantee minimum chip-to-chip-time.

The chain magazine has 40 and optionally 60/80/120 storage locations for tools up to a diameter of 325 mm, a length up to 800 mm and a unit weight up to 35 kg. With tool lengths up to 800 mm, inaccurate and time-consuming shift drilling can be omitted. In case of

a higher tool demand, the machining centers can be equipped with the new modular tower magazines with a storage capacity of either 180, 270, 360 or 450 tools. Tools and additional equipment with a diameter up to 340 mm, a length up to 800 mm and max. 50 kg unit weight can be stored.

Advantages of these magazines are high changing dynamics, optimum production process reliability, retooling during the machine run time and a high ease of use resulting from access to all tools.

## Comfortable, quick and safe workpiece handling

The NC rotary table with direct drive and absolute angle measuring system offers ideal conditions for multi-side and complete machining.

The input resolution of 0.001 degrees and the max. speed up to 80 rpm stand for precision and dynamics. A positioning spread  $P_{max} 3''$  and a reversal error  $U_{max} 2''$  can be achieved. The pallets are available in square, rectangular or round design with threaded holes or T-grooves. The workpiece pallets can be equipped with a coupling unit for hydraulic workpiece fixtures with a clamping pressure of 30 to 240 bar.

# 5-axis machining centers with NC rotary and pivoting unit

Tower magazine with storage capacity for 450 tools in the stage of extension.

Chain magazine with either 40, 60 or 120 storage locations.



Heckert HEC 800 X5 in special design with tool tower magazine.

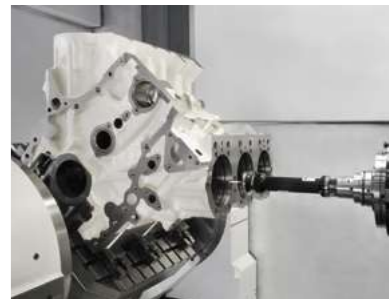
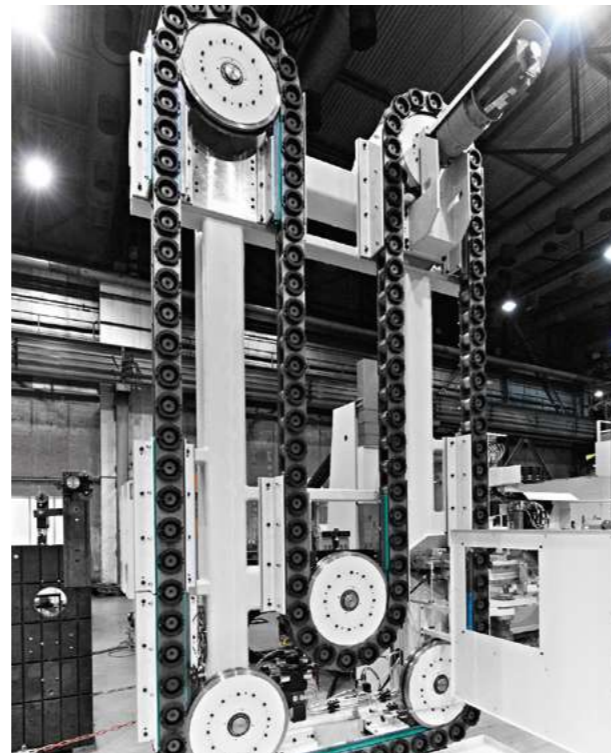

### Ease of use on the load-unload station

The workpieces are loaded and unloaded on the load-unload station parallel to the machining time. The rotating design of the load-unload station with 4 × 90 indexing facilitates the tooling work significantly. The hydraulic lifting/pivoting unit exchanges the pallets both quickly and safely from the load-unload station into the workspace. Splash shower in the workspace and rinsing gun at the load-unload station clean workpiece and device. The workspace is cleaned by a whirling nozzle and cover rinsing device.

### Increased production quality

A high-accuracy package (option) includes water cooling of the machine stand and the axis drives. Tempered ball screws are additionally used and the contact and support surfaces are scraped. Thus, the positioning accuracy in the adjustment axes is significantly improved (positioning uncertainty P[Tp] 0.004 mm).

### High-level energy efficiency

Reduction in operating costs by:

- Recovery of the energy when braking the drives
- Software for automatic machine shutdown
- Direct drive with high efficiency for motor spindle and NC rotary table
- Warm-up program and stand-by mode
- Automatic deactivation of the compressed air
- Accumulator charging circuit in the hydraulic system of the machine
- Energy-neutral, hydraulic weight compensation for positioning the spindle support
- Use of energy-saving lamps/energy-saving motors

For a further reduction of the production time per work piece, increase of the machining accuracy and assembly-oriented production, the machining centers Heckert HEC 500 X5 / HEC 630 X5 / HEC 800 X5 are equipped with a combined NC rotary and pivoting unit. The advantages are the complete production in one clamping and the machining of slanting surfaces and holes without axis interpolation.

This allows very high machining accuracies and surface qualities. The two-sided mounting and clamping of the pivot axis guarantees high stability. Absolute direct angle measuring systems ensure highest positioning precision and production accuracy. The reversal error  $U_{max}$  is 3" in the axis A and 2" in the axis B.



# High process integration with additional package MT (Multitasking)

NC rotary and pivoting unit and tool tower magazine as option.

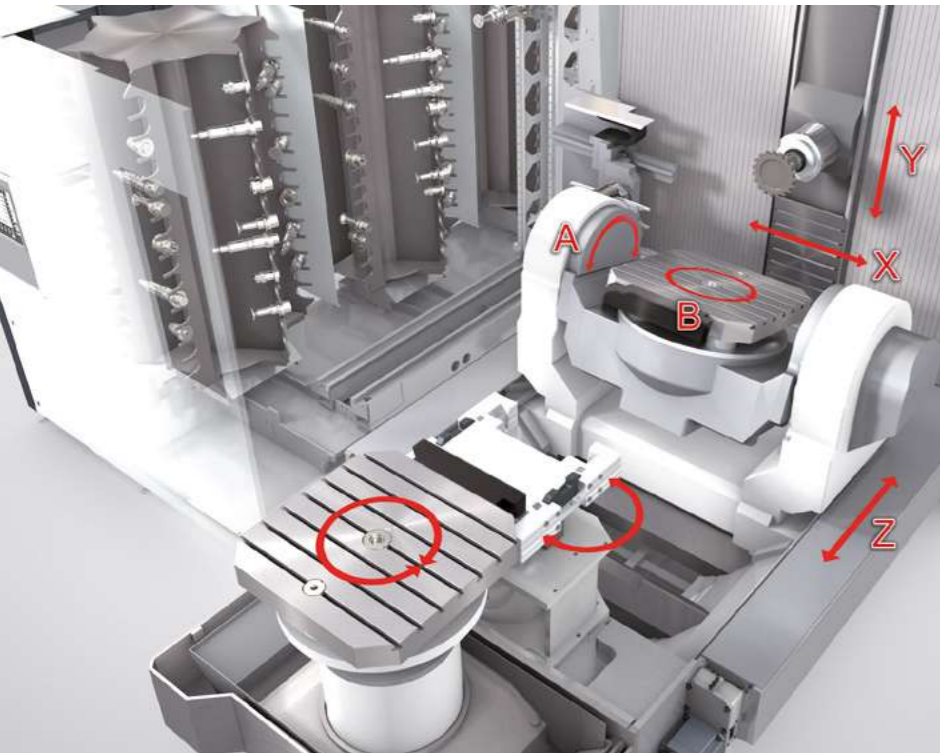

Optimum operational safety of the rotary and pivoting unit is achieved by clamping the rotational axis via a hydraulic safety circuit. Likewise, the additional mechanical clamping of the A-axis and mechanically locked clamping cones enhance the safety standard regarding the pallet clamping.

The additional package MT-X5 Multitasking extends the centers by rotationally symmetric machining such as turning and turn-milling. The basis for this are the NC rotary table with a maximum of 500 rpm and the automatic monitoring of the imbalance.

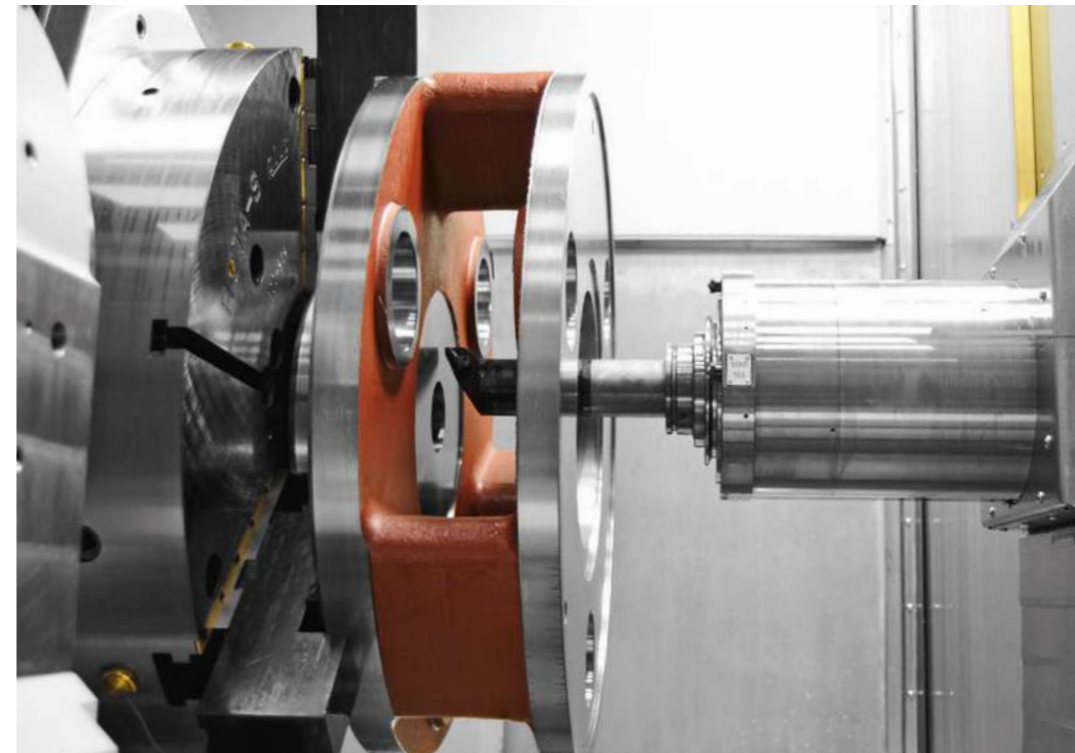

The complete machining in one clamping is a special challenge in order to further reduce the production and tooling times with a simultaneous increase of the machining quality.

Heckert has a perfect solution for this. The machining centers of the design size 500 to 800 Athletic and the X5-versions can be extended for Multitasking. Thus, these machining centers can additionally be used for rotationally symmetric machining such as turn-milling and turning (internal and external longitudinal cylindrical turning, planar cross turning).

The thermo-symmetric machine design with high static and dynamic rigidity, the main spindle with tool clamping by tight fit, the tool holder HSK-T100 for position accuracy and a directly driven NC rotary table provide optimum conditions for this. This rotary table with torque motor allows speeds up to 500 rpm with a maximum drive power up to 82 kW.

Thereby, the centers are equipped with imbalance-reduced pallets and automatic imbalance monitoring. With the package MT, both the processing times and the logistics expenses and the investment costs are reduced.



# Flexible production systems for unattended production

# High level of effectiveness in the application

Production line with 3 machining centers Heckert HEC 500 Athletic and workpiece transfer by gantry robot for fully.



The machining centers Heckert HEC 500 / 630 / 800 Athletic have interfaces for the automatic workpiece, tool and information flow as a precondition for the integration into flexible production systems and production lines. A wide range of modular system sub-assemblies for tool and workpiece handling, system control, software solutions and devices of process monitoring guarantee a customized production solution.

Flexible production system with 6 Machining Centers Heckert HEC 630 Athletic, pallet linear storage system and master control for for housing machining from batch size 1 up to large scale production.



The basic model of the pallet linear storage unit in container form consists of 6 to 10 storage locations, a stacking crane, a load and unload station, MMS control and PC terminal for operation. Additional pallet storage locations and clamping stations can be integrated into the system. The production systems und production lines can be adapted to the individual tasks with the assembly stations, washing machines, measuring and testing equipment, further machine tools and robot solutions for tool handling.

Turn-key projects as turnkey complete solutions include services such as engineering, overall project planning, delivery package machining centers – system modules – clamping technology – tools, training courses, commissioning, service, maintenance and production support.



Ready-for-assembly complete machining of bush housings for the railway technology on the Heckert HEC 630 Athletic. Implementation as turn-key project from engineering to training and production support.



Semi-finish and finish machining of crankcases for V8 cylinder diesel engines in 2 clamping positions on the Heckert HEC 800 Athletic. High flexibility of machining different crankcases with universal clamping technology and the same tool sets.

Flexible complete machining of different pivot housings for haulers on the Heckert HEC 500 Athletic with automatically exchangeable NC radial facing slide. Alternative solution with the advantage of reducing the processing time and the logistics expenses compared to machining on lathes.



Production of housings for rotary feeders for bulk material dosage on the Heckert HEC 630 Athletic. Finish machining of the rotor bore hole up to a diameter of 120 mm with bridge tool. Production time reduction by 30 % as a result of fully automatic machining.

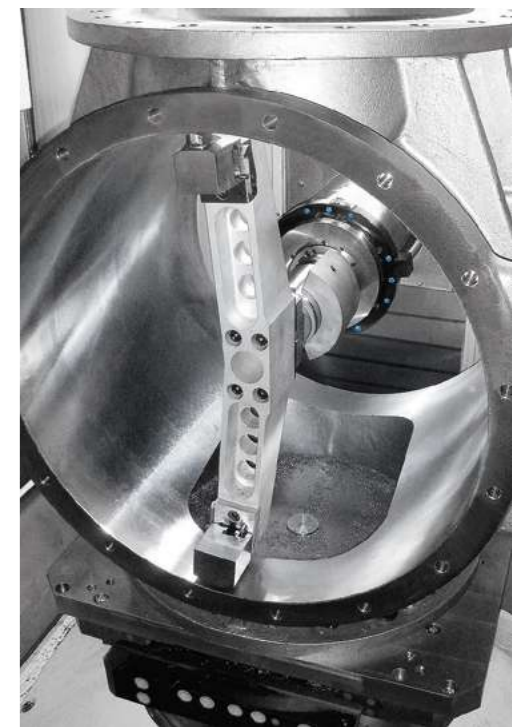

# Technical data

Values in brackets = options  
\*(HSK-T 100 with MT)

<b>Heckert HEC 500 Athletic</b>		
<b>Design work spindle</b>	Horizontal	
<b>Design table</b>	NC rotary table	
Clamping area/punched-hole pallet DIN 55201	mm	500 × 500 (500 × 630) (round pallet Ø 630)
Max. load	kg	1,000
Workpiece interference range		
[full circle/flattened]	mm	1,000/1,350
Max. workpiece and device height	mm	1,050
<b>Adjustment ranges</b>		
Column longitudinal motion X	mm	1,000
Slide rest vertical motion Y	mm	800 (950)
Table transverse motion Z	mm	1,000
Rotation range B-axis	deg	0...360
Swivel range A-axis	deg	-
<b>Work spindle</b>	Gear spindle, Motor spindle, NC quill	
Tool holder	HSK-A 100 (SK 50/BT/CAT 50)	
Drive power	kW	50...82
Torque, 25% c.d.f.	Nm	237...1,500
Max. speed	rpm	4,000...15,000
<b>Tool change</b>	Chain	Tower
Magazine storage locations	40 (60/120)	180/270/360/450
Max. tool diameter	mm	325 340
Max. tool length	mm	700 450/800
<b>Traversing velocity</b>		
Rapid traverse	m/min	65
Max. speed B-axis	rpm	80
Max. speed A-axis	rpm	-
<b>Machine accuracy to VDI/DGQ 3441</b>		
Linear axes X/Y/Z		
Positioning uncertainty P[Tp]	mm	0.006 (0.004)
Position spread P <sub>smax</sub>	mm	0.004 (0.0025)
Reversal error U <sub>max</sub>	mm	0.003 (0.001)
NC rotary table/B-axis		
Positioning uncertainty P[Tp]	arcsec	6 (4)
Position spread P <sub>smax</sub>	arcsec	4 (3)
Reversal error U <sub>max</sub>	arcsec	3 (2)
A-axis		
Positioning uncertainty P[Tp]	arcsec	-
Position spread P <sub>smax</sub>	arcsec	-
Reversal error U <sub>max</sub>	arcsec	-
<b>CNC control</b>	Siemens 840D SL with HMI Operate (Fanuc 31i)	

<b>Heckert HEC 500 X5</b>		<b>Heckert HEC 630 Athletic</b>	
Horizontal		Horizontal	
NC rotating and tilting unit		NC rotary table	
500 × 500 (500 × 630) (Ø 630)		630 × 630 (630 × 800) (Ø 800)	
800		1,500	
1,000		1,250/1,550	
650		1,250	
1,000		1,200	
800 (950)		950 (1,100)	
1,000		1,200	
0...360		0...360	
-45...+91, +45...-91		-	
Gear spindle, Motor spindle, NC quill		Gear spindle, Motor spindle, NC quill	
HSK-A 100 (SK 50/BT/CAT 50)*		HSK-A 100 (SK 50/BT/CAT 50)	
50...82		50...82	
237...1 500		237...1 500	
6 000...15 000		4 000...15 000	
Chain	Tower	Chain	(Tower)
40 (60/120)	180/270/360/450	40 (60/120)	(180/270/360/450)
325	340	325	(340)
600	450/600 (500 with MT)	800	(450/800)
65		65	
80 (500 with MT)		70	
15		-	
0.006		0.006 (0.004)	
0.004		0.004 (0.0025)	
0.003		0.003 (0.001)	
6 (4)		6 (4)	
4 (3)		4 (3)	
3 (2)		3 (2)	
6		-	
4		-	
3		-	
Siemens 840D SL with HMI Operate (Fanuc 31i)		Siemens 840D SL with HMI Operate (Fanuc 31i)	

# Technical data.

Values in brackets = options  
\*(HSK-T 100 with MT)

<b>Heckert HEC 630 X5</b>		
<b>Design work spindle</b>	Horizontal	
<b>Design table</b>	NC rotary and pivoting unit	
Clamping area/punched-hole pallet DIN 55201	mm	630 × 630 (630 × 800) (Ø 800)
Max. load	kg	1,000
Workpiece interference range		
[full circle/flattened]	mm	1,250
Max. workpiece and device height	mm	800
<b>Adjustment ranges</b>		
Column longitudinal motion X	mm	1,200
Slide rest vertical motion Y	mm	950 (1,100)
Table transverse motion Z	mm	1,200
Rotation range B-axis	deg	0...360
Swivel range A-axis	deg	-45...+91, +45...-91
<b>Work spindle</b>	Gear spindle, Motor spindle, NC quill	
Tool holder	HSK-A 100 (SK 50/BT/CAT 50)*	
Drive power	kW	50...82
Torque, 25% c.d.f.	Nm	237...1,500
Max. speed	rpm	6,000...15,000
<b>Tool change</b>	Chain	Tower
Magazine storage locations	40 (60/120)	180/270/360/450
Max. tool diameter	mm	325 340
Max. tool length	mm	800 450/800 (700 with MT)
<b>Traversing velocity</b>		
Rapid traverse	m/min	65
Max. speed B-axis	rpm	70 (500 with MT)
Max. speed A-axis	rpm	15
<b>Machine accuracy to VDI/DGQ 3441</b>		
Linear axes X/Y/Z		
Positioning uncertainty P[Tp]	mm	0.006
Position spread P <sub>max</sub>	mm	0.004
Reversal error U <sub>max</sub>	mm	0.003
NC rotary table/B-axis		
Positioning uncertainty P[Tp]	arcsec	6 (4)
Position spread P <sub>max</sub>	arcsec	4 (3)
Reversal error U <sub>max</sub>	arcsec	3 (2)
A-axis		
Positioning uncertainty P[Tp]	arcsec	6
Position spread P <sub>max</sub>	arcsec	4
Reversal error U <sub>max</sub>	arcsec	3
<b>CNC control</b>	Siemens 840D SL with HMI Operate (Fanuc 31i)	

<b>Heckert HEC 800 Athletic</b>		<b>Heckert HEC 800 X5</b>	
Horizontal		Horizontal	
NC rotary table		NC rotating and tilting unit	
800 × 800 (800 × 1,000) (Ø 1,000)		8,000 × 800 (800 × 1,000) (Ø 1,000)	
2,000		1,200	
1,400/1,750		1,400	
1,400		1,000	
1,450		1,450	
1,100(1,300)		1,100 (1,300)	
1,300 (2,050)		1,300 (2,050)	
0...360		0...360	
-		-45...+91, +45...-91	
Gear spindle, Motor spindle, NC quill		Gear spindle, Motor spindle, NC quill	
HSK-A 100 (SK 50/BT/CAT 50)		HSK-A 100 (SK 50/BT/CAT 50)*	
50...82		50...82	
237...1,500		6,000...15,000	
4,000...15,000		6,000...15,000	
Chain	Tower	Chain	Tower
40 (60/120)	180/270/360/450	40 (60/120)	180/270/360/450
325	340	325	340
800	450/800	800	450/800 (700 with MT)
65		65	
60		60 (500 with MT)	
-		15	
0.006 (0,004)		0.006	
0.004 (0,0025)		0.004	
0.003 (0,001)		0.003	
6 (4)		6 (4)	
4 (3)		4 (3)	
3 (2)		3 (2)	
-		6	
-		4	
-		3	
Siemens 840D SL with HMI Operate (Fanuc 31i)		Siemens 840D SL with HMI Operate (Fanuc 31i)	

Starrag GmbH  
Otto-Schmerbach-Strasse 15/17  
09117 Chemnitz  
Germany

P +49 371 836 22 88

[sales.heckert@starrag.com](mailto:sales.heckert@starrag.com)

