

VASTUNA

緯斯特有限公司  
VASTUNA LTD.

Deep Hole Drilling Machine  
深孔加工機械

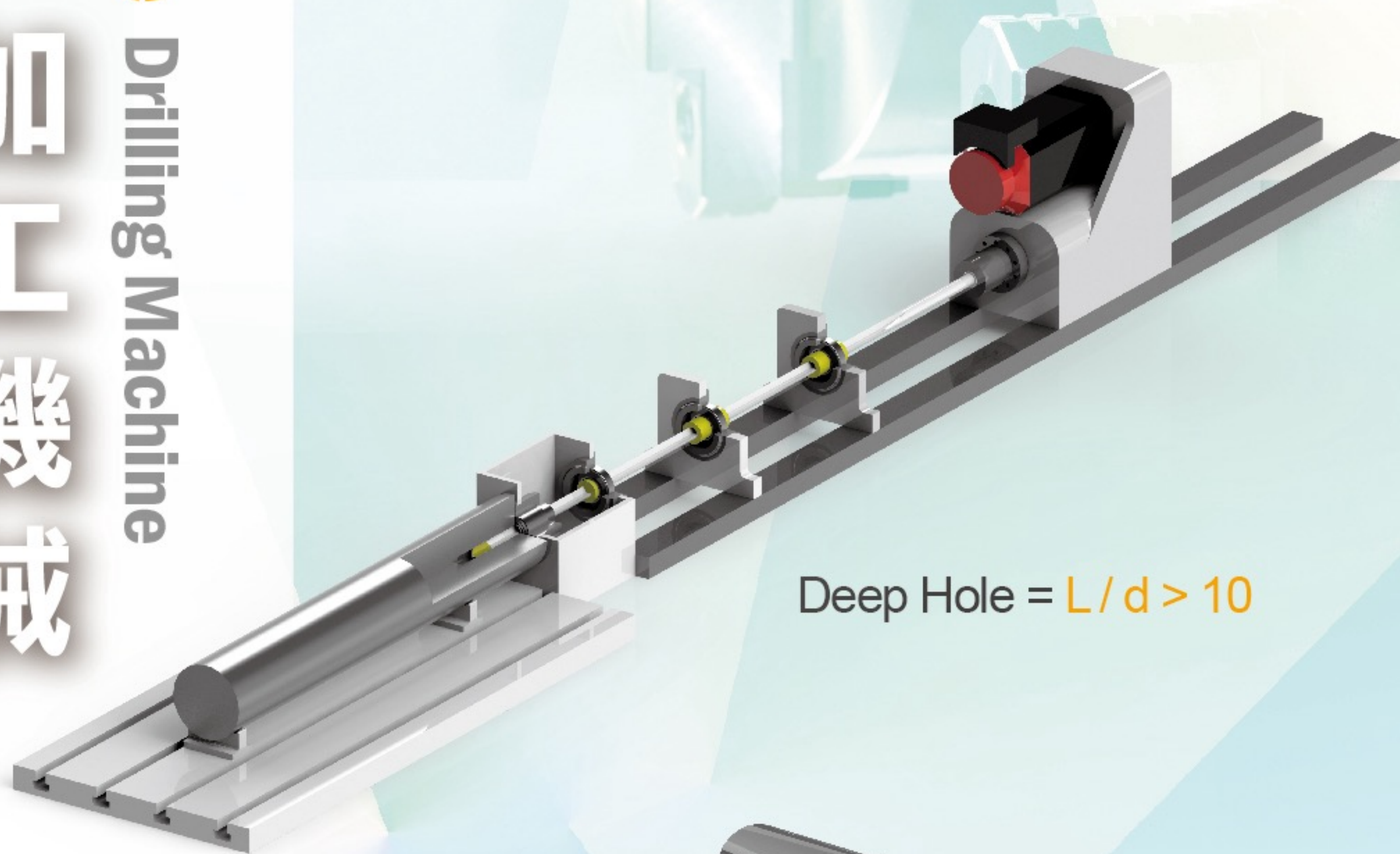

Deep Hole =  $L/d > 10$

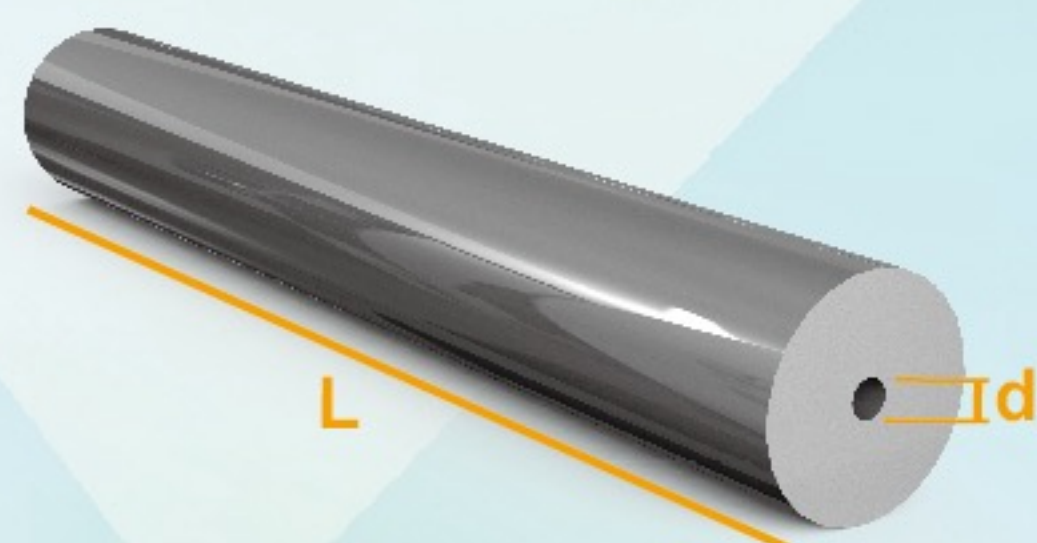

槍鑽系統  
Gun Drilling System

砲鑽(BTA)系統  
BTA Drilling System

VASTUNA

## R 系列 Series



更多資訊 Information ▶



### 中量型槍鑽鑽孔機 Medium Duty Gundrills

槍鑽軸數 Number of spindle	1 / 2 / 4	夾頭尺寸 3-jaw chuck size	10" (Opt.:12") / 7"
鑽孔直徑 Drilling diameter	Ø3~40mm	刀具旋轉 Tool rotation	V
鑽孔深度 Drilling depth	500~3000mm	工件旋轉 Workpiece rotation	選配 Opt.



軸心孔位鑽孔  
Center hole drilling

## RS 系列 Series

更多資訊 Information



### 微小孔槍鑽鑽孔機 Micro Drilling Gundrills

- ✓ 可變更為錐盤夾持
- ✓ Can change to cone clamping

槍鑽軸數 Number of spindle	2 / 4	夾頭尺寸 3-jaw chuck size	7" / 6" / 4"
鑽孔直徑 Drilling diameter	Ø1.5 ~ 6mm	刀具旋轉 Tool rotation	V
鑽孔深度 Drilling depth	300 ~ 500mm	工件旋轉 Workpiece rotation	選配 Opt.



軸心孔位鑽孔  
Center hole drilling

# S 系列 Series

更多資訊 Information

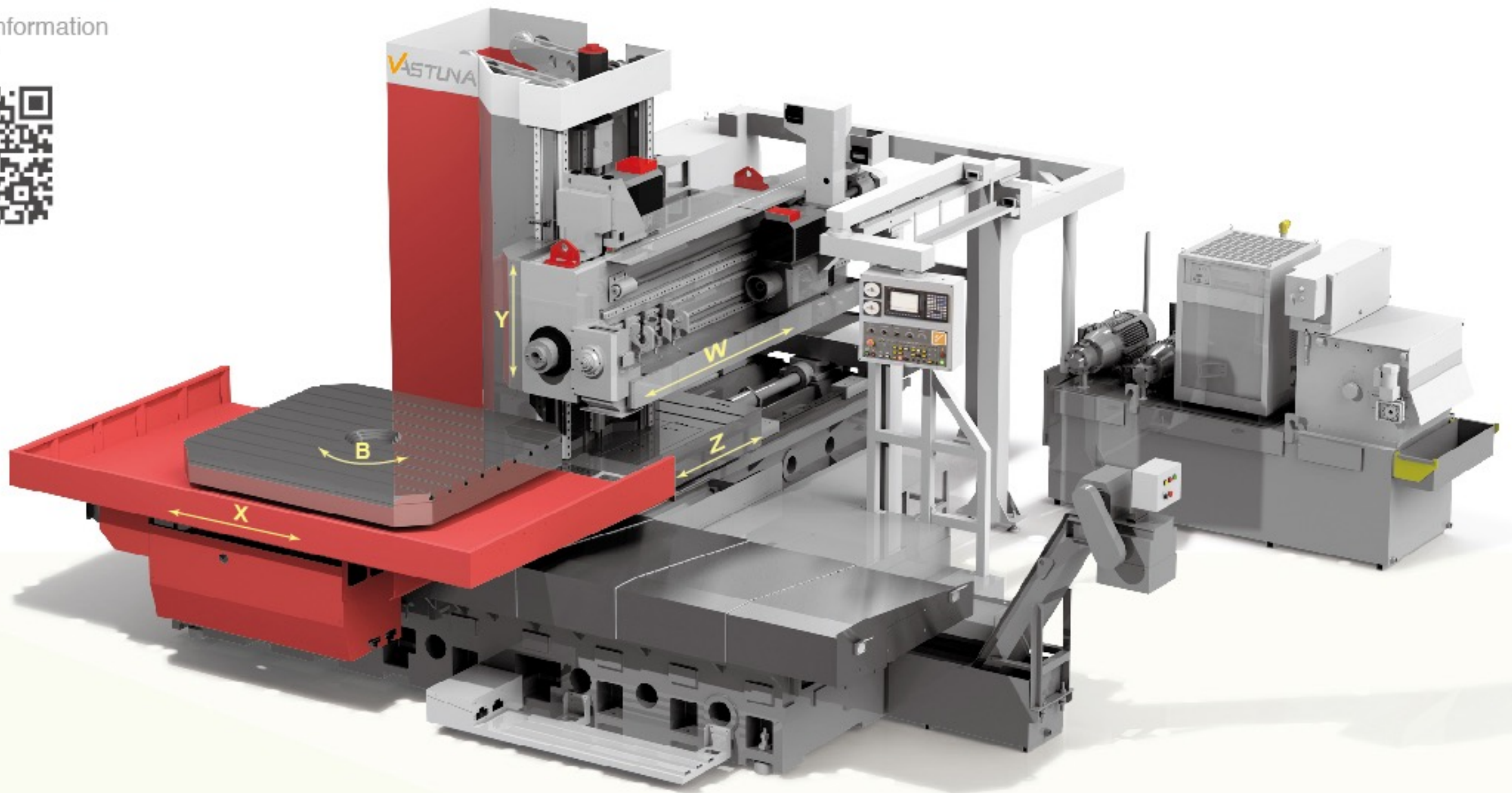

## 高效能多軸向槍鑽鑽孔機 Efficient Multi Axes Gundrills

鑽孔直徑 Drilling diameter	Ø3~30mm (Opt.:Ø4~40mm)	槍鑽軸數 Number of spindle	1
鑽孔深度 Drilling depth	1500mm	工作臺尺寸 Working table size	1400x1600mm
X 軸行程 X axis travel	2000~3000mm	工作臺荷重 Loading capacity	7000kgs
Y 軸行程 Y axis travel	1000~1500mm	旋轉角度 Degree	0.001

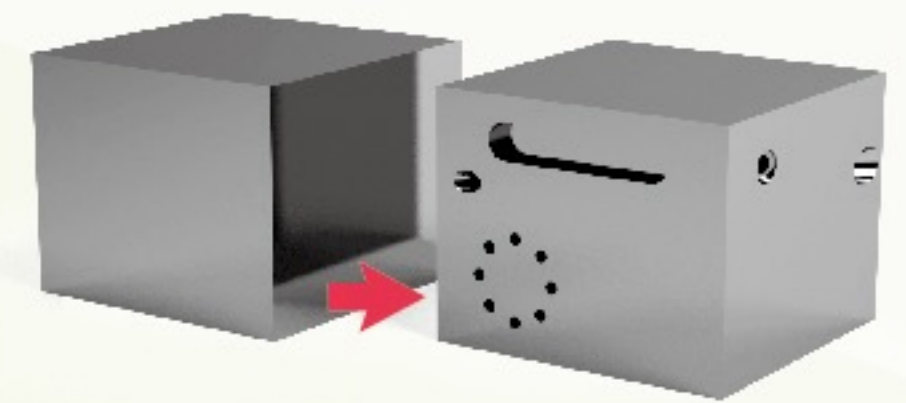

偏心孔位鑽孔、銑削、攻牙  
Various X, Y axes position hole, Milling, Taping

## 操作面板 Controller

VASTUNA 全系列機型提供 Mitsubishi、Fanuc 與 Siemens 三種控制系統供客戶選擇之外。

VASTUNA all series machine provides three types of the controller (Fanuc, Mitsubishi or Siemens).

### ▼ Mitsubishi



### ▼ Fanuc



### ▼ Siemens



## F 系列 Series

更多資訊 Information



### 輕量型三座標槍鑽鑽孔機 Light Duty Three Axes Gundrills

鑽孔直徑 Drilling diameter	Ø3~30mm (Opt.:Ø4~40mm)	槍鑽軸數 Number of spindle	1
鑽孔深度 Drilling depth	800mm (Opt.:1000 / 1500mm)	工作臺尺寸 Working table size	1200x1000mm 1000x1200mm
X 軸行程 X axis travel	800 / 1000mm	工作臺荷重 Loading capacity	3000kgs
Y 軸行程 Y axis travel	800 / 600mm		

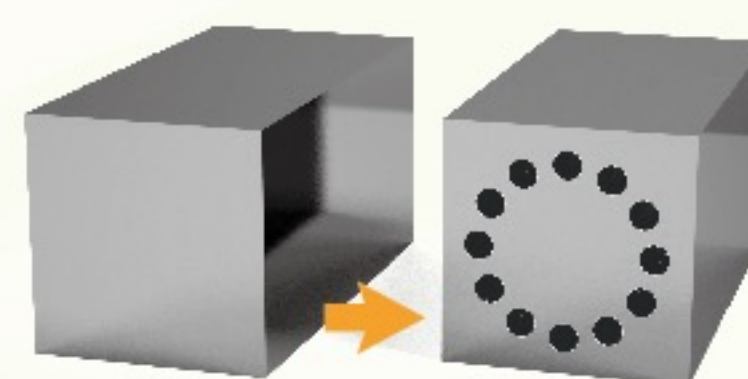

偏心孔位鑽孔  
Various X, Y axes position hole

## FC 系列 Series

更多資訊 Information

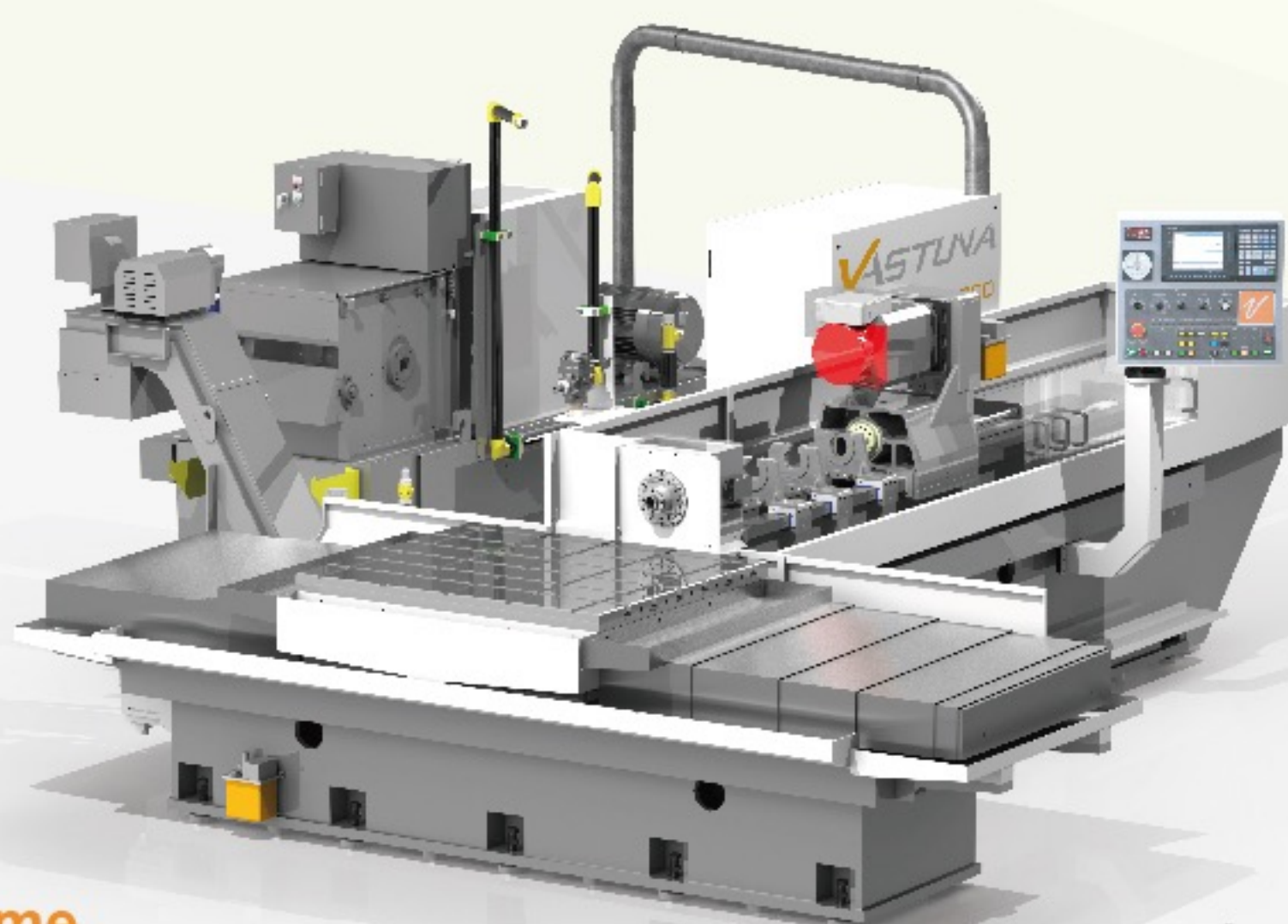

### 加熱板鑽孔專用機 Heat Plate Drilling Machine

鑽孔直徑 Drilling diameter	Ø3~25mm (Opt.:Ø4~30mm)	槍鑽軸數 Number of spindle	1
鑽孔深度 Drilling depth	800mm (Opt.:1000mm)	工作臺尺寸 Working table size	1000x1200mm 1600x2700mm
X 軸行程 X axis travel	1000mm / 2500mm	工作臺荷重 Loading capacity	3000kgs

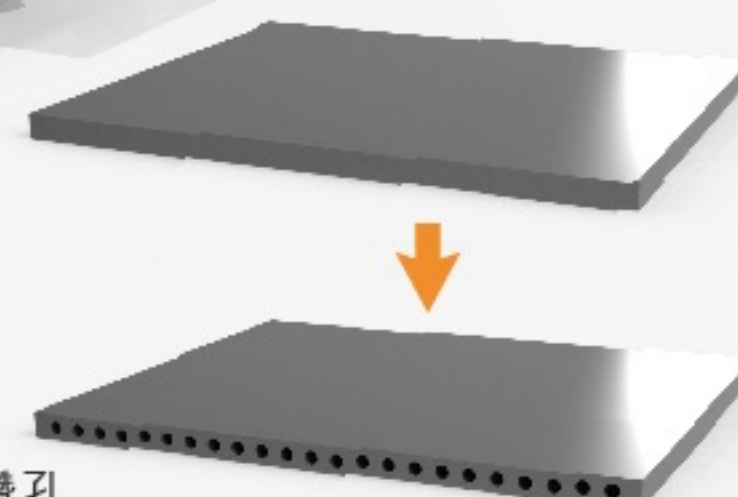

加熱板鑽孔  
Heat plate drilling

**B** 系列  
Series



更多資訊 Information ▶

由英國 **mollart** 獨家代理 / Exclusive agent by **mollart**

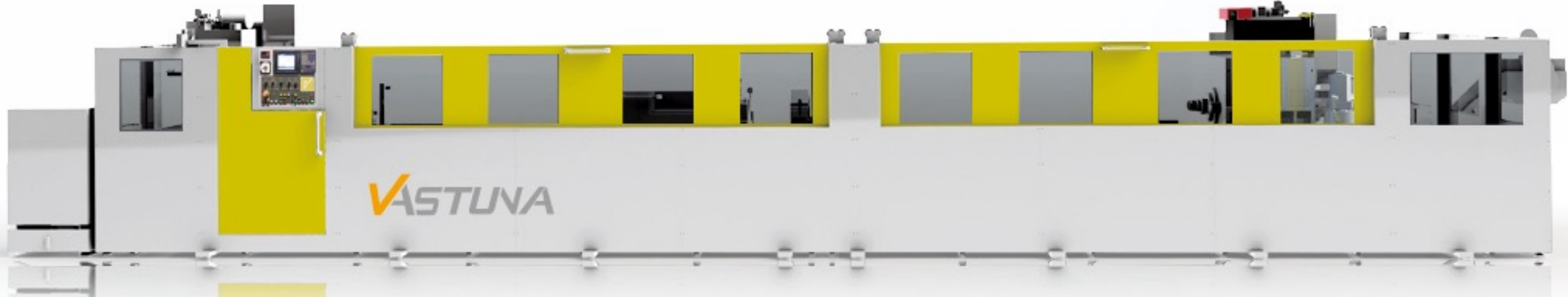

## 重型 BTA 鑽孔機 Heavy Duty BTA drills

鑽孔直徑 Drilling diameter	Ø18~150mm	槍鑽軸數 Number of spindle	1
鑽孔深度 Drilling depth	2500~6000mm	夾頭尺寸 3-jaw chuck size	25" 手動夾頭 25" manual
搪孔直徑 Boring Diameter	2000~3000mm	刀具旋轉 Tool rotation	V
驅動方式 Drive	精密排齒驅動 Gear drive	工件旋轉 Workpiece rotation	V

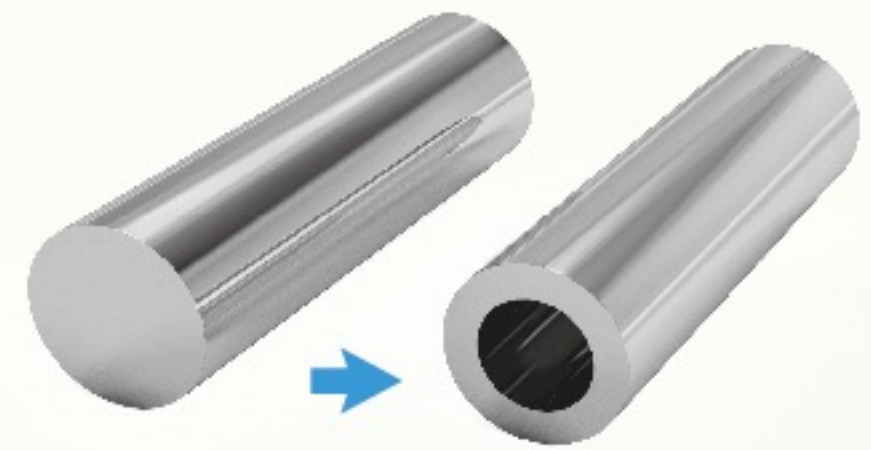

軸心孔位鑽孔  
Center hole drilling

**BV** 系列  
Series



更多資訊 Information ▶



## 重型 BTA 鑽孔機 Heavy Duty BTA drills

鑽孔直徑 Drilling diameter	Ø30~110mm (Opt.:30~150mm)	槍鑽軸數 Number of spindle	1 / 2
鑽孔深度 Drilling depth	500~3000mm	夾頭尺寸 3-jaw chuck size	10" / 16" 手動 manual (Opt.: 20" 手動 manual )
驅動方式 Drive	滾珠螺桿驅動 Ball screw drive ball	工件旋轉 Workpiece rotation	選配 Opt.
刀具旋轉 Tool rotation	V		



軸心孔位鑽孔  
Center hole drilling

**D1** 系列  
Series

更多資訊 Information ▶



**VAST DRY**<sup>®</sup>  
WWW.VASTUNA.COM

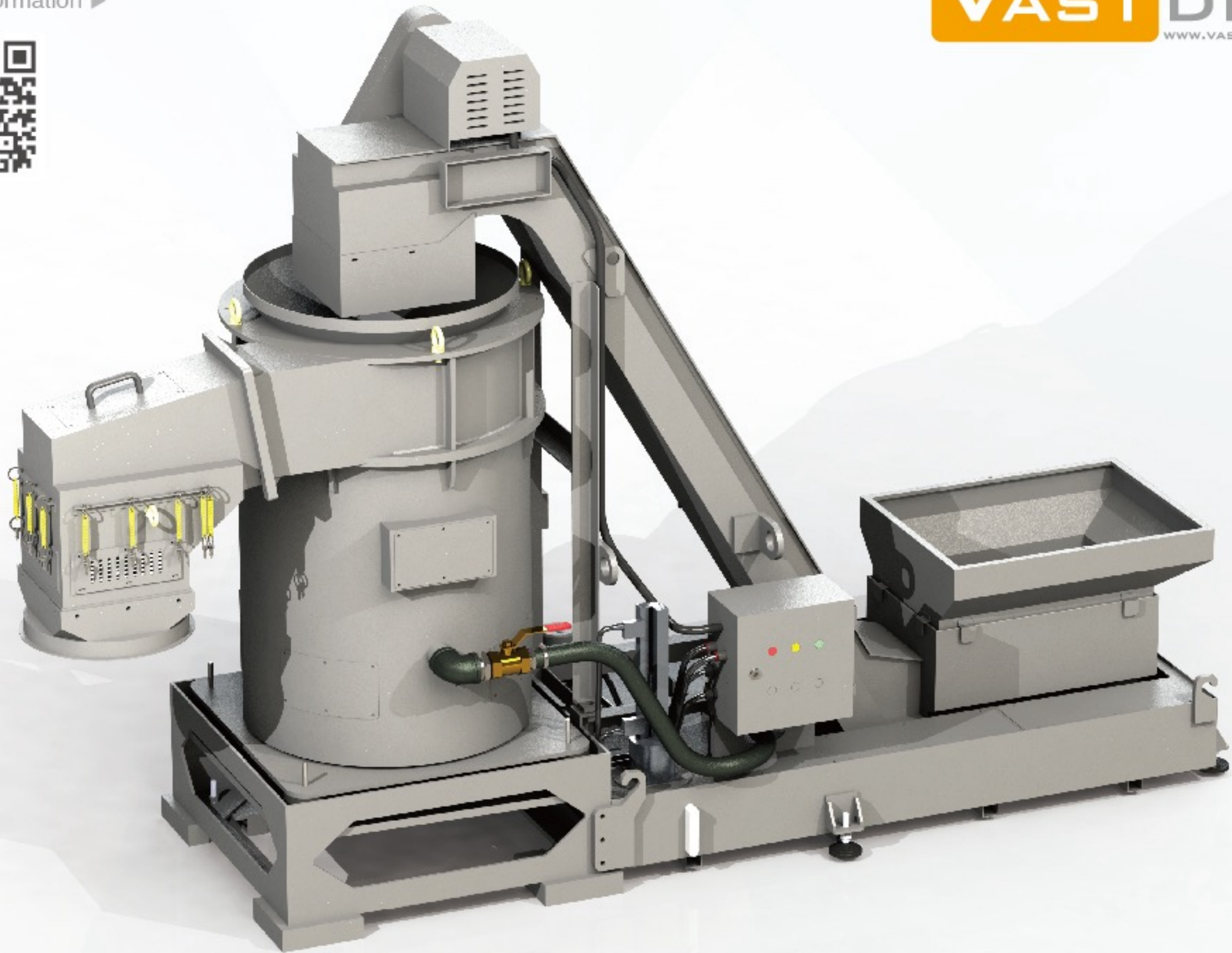

## 全自動化離心脫油機 Continuous chips dryer

外型尺寸 Size	1390 x 1060 x 1010 mm
馬達 Motor	2.2kw
轉速 Speed	1,150 rpm

### 注意！ Attention !

此為脫油機使用示意圖，本產品不含排屑輸送機  
This is the automatic centrifuge dryer use sample diagram,  
this product doesn't include chip conveyor

Deep Hole Drilling Systems

Deep Hole Drilling Machines

Deep Hole Drilling Tools

**VASTUNA**

緯斯特有限公司  
VASTUNA LTD.



Tel: +886-4-25615595 Fax: +886-4-25615695

429 台中市神岡區中山路667巷26弄16號

No.16, Aly. 26, Ln. 667, Zhongshan Rd.,  
Shengang Dist., Taichung City 429, Taiwan

[www.vastuna.com](http://www.vastuna.com)

[info@vastuna.com](mailto:info@vastuna.com)