

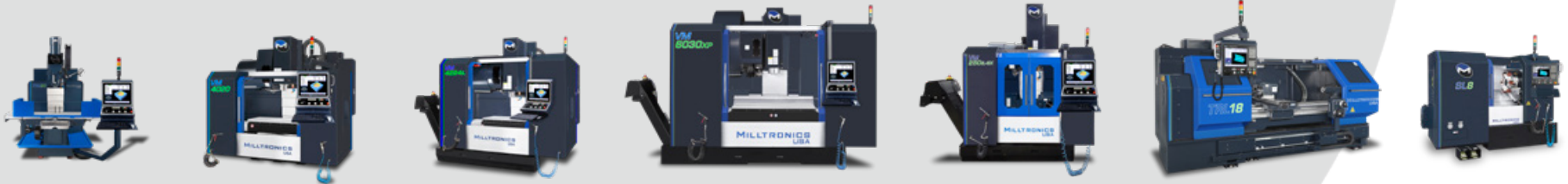

MILLTRONICS®



PRODUCT CATALOG



MILLTRONICS.COM | 888.999.1440



For over 50 years, Milltronics has been committed to seamlessly surround machine shop owners and manufacturers with fast and reliable full life-cycle support to make great products. We proudly serve the CNC machining industry worldwide by offering our innovative control and manufacture a complete line of vertical machining centers & lathes for toolroom and production environments. Each machine is configured to our customers' specifications and business needs while providing the most affordable solution to match the investment and accelerate the ROI.

We have built our reputation on three differentiators:

- Conversational Control
- Accurate & Reliable Machines
- Dedicated & Solution-Minded People

Since 1973 and with over 14,000 machine installations, these differentiators have allowed Milltronics to go above and beyond to provide our customers with exceptional machining performance, at a price they can afford, with the assurance that we will stand behind our products and be true to our word.

 **MILLTRONICS®** **Beyond Expectations.**



MILLTRONICS® CNC MACHINE LINE-UP



ONLINE PRICING AT
MILLTRONICS.COM/GETPRICING

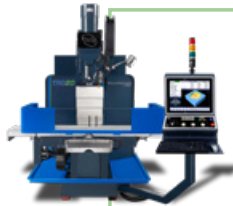

3-AXIS TOOL ROOM MILLS

Milltronics has a long history of building tool room mills that can be run as manual, or full CNC. Popular in tool rooms, job shops, and tool & die, these machines are very flexible and can be used for a wide variety of parts.



GENERAL PURPOSE 3-AXIS VERTICAL MACHINING CENTERS

The VM Series CNC mills offer a great combination of standard features (that the other guys charge extra for) and performance at a great price.

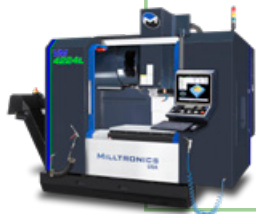

PERFORMANCE IL 3-AXIS VERTICAL MACHINING CENTERS

The IL Series machines have inline spindles, roller guides for rigidity, direct-coupled ballscrews for quick response, and dual wound spindles for faster acceleration/deceleration.

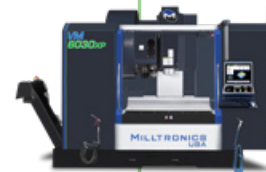

EXTRA POWER 3-AXIS VERTICAL MACHINING CENTERS

XP Series VMCs are #50 taper machines built with robust cross rollers and high torque dual speed spindle motors.



5-AXIS VERTICAL MACHINING CENTERS

Milltronics 5-axis vertical machining centers are built for rigidity and powered by the INSPIRE+ control, which provides improved surface finish and cycle times, an advanced proprietary motion engine, and a 19-inch LCD touch screen.

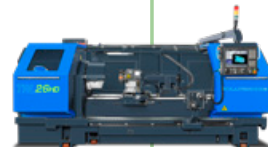

TOOL ROOM LATHES

The TRL Series of tool room lathes offer the versatility to be run manually or through the control. With a combination of robust turning and milling capabilities, TRL lathes are designed for high-performance machining in a compact form.



SLANT BED CNC LATHES

The SL Series CNC lathes feature robust true slant bed castings, roller ways for rigidity, direct coupled ballscrews and more.



MILLTRONICS CONTROL

The Milltronics control (INSPIRE+ & 9000 DGI) offers a user-friendly interface, conversational programming, powerful G-code processing, and several software features that will enhance your shop's productivity.

3-AXIS TOOL ROOM MILLS

40 TAPER

Milltronics has a long history of building tool room mills that can be run as manual or full CNC with thousands of satisfied users. Popular in tool rooms, job shops, and tool & die, these machines are very flexible and can be used for a wide variety of different parts. We offer two types of quill machines in a traditional knee style (VK) as well as a bed type (TRQ). The rigid head (TRM) machines are available in four different sizes starting with a compact model that is 30 x 16 inches up to the largest that has 78 x 33 inches of travel.



VK4II – MILLSLIDE™

The unique MillSlide™ on the VK4II provides rigid, CNC programmable, Z-axis travel. By traversing the entire head up and down the MillSlide™ is more robust than competitors' quill-driven solutions. The optional Quill Scale integrates with the CNC feedback and you have a built in Z-axis DRO.



INCLUDED AT NO EXTRA COST

STANDARD FEATURES

- ✓ Solid box way construction (most models)
- ✓ X/Y axis metal way cover construction (most models)
- ✓ Auto lubrication
- ✓ ISO No. 40
- ✓ Spindle load meter
- ✓ Spindle air purge (excluding VK / TRQ models)
- ✓ Flood coolant
- ✓ Rigid tapping (excluding VK model)
- ✓ One year warranty
- ✓ INSPIRE+ Control

OPTIONS (AVAILABILITY VARIES BY FRAME)

- Enclosure top cover
- Chip auger
- Remote handwheel
- Milltronics rotary tables
- Renishaw tool and part probes
- Programmable spray mist or air blast
- Auxiliary keyboard
- Extended warranty
- Factory start-up and on-site training
- Training at Milltronics (Indianapolis, IN)
- Printed manuals (PDF standard)
- Milltronics logo floor mat
- ChipBoss™ Trochoidal Milling Software
- Milltronics Shop View
- Offline DGI software
- Quill scale

Specifications subject to change without notice. Some machines shown with options.



ONLINE PRICING AT
MILLTRONICS.COM/
GETPRICING

SPECIFICATIONS	VK4II	TRQ20	TRM3016	TRM20	TRM30	TRM30HT	TRM33HT
TABLE							
TABLE WORKING SURFACE	54 x 12 in (1,370 x 305 mm)	54 x 16 in (1,372 x 406 mm)	35.4 x 16 in (900 x 406 mm)	54 x 16 in (1,372 x 406 mm)	73 x 24 in (1,853 x 610 mm)	73 x 24 in (1,853 x 610 mm)	86 x 32 in (2,185 x 810 mm)
TABLE T-SLOTS	3 x .63 in (16 mm)	3 x .63 in (16 mm)	3 x .71 in (18 mm)	3 x .63 in (16 mm)	5 x .71 in (18 mm)	5 x .71 in (18 mm)	5 x .71 in (18 mm)
MAXIMUM WEIGHT ON TABLE	1,324 lbs (600 kg)	1,323 lbs (600 kg)	992 lbs (450 kg)	1,323 lbs (600 kg)	2,866 lbs (1,300 kg)	2,866 lbs (1,300 kg)	3,960 lbs (1,800 kg)
TRAVELS							
X-AXIS	33 in (838 mm)	39.4 in (1,000 mm)	30 in (762 mm)	39.4 in (1,000 mm)	59.8 in (1,520 mm)	59.8 in (1,520 mm)	78 in (2,000 mm)
Y-AXIS	14.3 in (362 mm)	19.7 in (500 mm)	16 in (406 mm)	19.7 in (500 mm)	29 in (740 mm)	29 in (740 mm)	33 in (840 mm)
Z-AXIS	QUILL: 5.83 in (148 mm) MILLSLIDE: 5.25 in (133 mm)	23.6 in (600 mm)	20 in (508 mm)	23.6 in (600 mm)	28 in (710 mm)	28 in (710 mm)	28 in (710 mm)
SPINDLE MOTOR							
SPINDLE POWER (MAXIMUM)	14.75/7.5 HP (11/5.5 kW)	14.75/7.5 HP (11/5.5 kW)	17.4/10 HP (13/7.5 kW)	20/15 HP (15/11 kW)	20/15 HP (15/11 kW)	25/15 HP (18/11 kW)	25/15 HP (18/11 kW)
SPINDLE TORQUE (MAXIMUM)	348/174 ft-lbs (473/236.5 Nm)	295/174 ft-lbs (400/236.5 Nm)	76.3/44 ft-lbs (103.5/59.7 Nm)	66/42.6 ft-lbs (89.4/57.8 Nm)	66/42.6 ft-lbs (89.4/57.8 Nm)	155/88 ft-lbs (210/119.4 Nm)	155/88 ft-lbs (210/119.4 Nm)
SPINDLE							
SPINDLE TAPER	CAT 40	CAT 40	BIG-PLUS® ISO. No. 40	BIG-PLUS® ISO. No. 40	BIG-PLUS® ISO. No. 40	BIG-PLUS® ISO. No. 40	BIG-PLUS® ISO. No. 40
SPINDLE NOSE TO TABLE	1.75-23.25 in (45-591 mm)	7.1-30.7 in (180-780 mm)	4-24 in (101-610 mm)	3.94-27.5 in (100-700 mm)	3.94-31.89 in (100-810 mm)	3.94-31.89 in (100-810 mm)	4-32 in (100-810 mm)
SPINDLE SPEED (MAXIMUM)	4,000 RPM	4,000 RPM	8,000 RPM	8,000 RPM	8,000 RPM	8,000 RPM	8,000 RPM
TOOL CHANGER							
TOOL CAPACITY / TYPE	—	—	16 / CAROUSEL	24 / CAROUSEL	24 / CAROUSEL	24 / CAROUSEL	24 / CAROUSEL
TOOL SHANK	CAT 40	CAT 40	CAT 40	CAT 40	CAT 40	CAT 40	CAT 40
RETENTION KNOB	—	—	MAS 60	MAS 60	MAS 60	MAS 60	MAS 60
MAXIMUM TOOL DIAMETER	—	—	4 in (100 mm)	3.54 in (90 mm)	3.54 in (90 mm)	3.54 in (90 mm)	3.54 in (90 mm)
MAXIMUM TOOL LENGTH	—	—	11 in (280 mm)	11.8 in (300 mm)	11.8 in (300 mm)	11.8 in (300 mm)	11.8 in (300 mm)
MAXIMUM TOOL WEIGHT	—	—	10 lbs (4.5 kg)	11 lbs (5 kg)	11 lbs (5 kg)	11 lbs (5 kg)	11 lbs (5 kg)
FURTHER DETAILS							
X/Y/Z RAPID TRAVERSE RATE	300 IPM (7.62 m/min)	500 IPM (12 m/min)	700 IPM (17.8 m/min)	500 IPM (12 m/min)	500 IPM (12 m/min)	500 IPM (12 m/min)	800/800/600 IPM (20/15 m/min)
MACHINE HEIGHT	104 in (2,634 mm)	101 in (2,564 mm)	110.9 in (2,817 mm)	102.5 in (2,603 mm)	108.9 in (2,766 mm)	108.9 in (2,766 mm)	113 in (2,870 mm)
FOOTPRINT: MAXIMUM SERVICE SPACE - (WIDTH x DEPTH)	117.95 x 85 in (2,996 x 2,168 mm)	120.5 x 142 in (3,061 x 3,607 mm)	183.3 x 121.2 in (4,657 x 3,077 mm)	120.5 x 142 in (3,061 x 3,607 mm)	177.1 x 147.5 in (4,498 x 3,746.5 mm)	177.1 x 174.7 in (4,498 x 4,436 mm)	238 x 162 in (6,045 x 4,115 mm)
FOOTPRINT: NOMINAL OPERATING - (WIDTH x DEPTH)	107 x 85 in (2,718 x 2,168 mm)	120.5 x 113.3 in (3,061 x 2,878 mm)	87.4 x 92.6 in (2,220 x 2,352 mm)	120.4 x 113.5 in (3,058 x 2,883 mm)	177.1 x 147.5 in (4,498 x 3,746.5 mm)	177.1 x 147.5 in (4,498 x 3,746.5 mm)	236 x 137.9 in (5,996 x 3,503 mm)
MACHINE WEIGHT	4,300 lbs (1,950 kg)	6,393 lbs (2,900 kg)	6,900 lbs (3,130 kg)	6,393 lbs (2,900 kg)	11,023 lbs (5,000 kg)	11,023 lbs (5,000 kg)	15,000 lbs (6,800 kg)
POWER REQUIRED	13 KVA/32 Amps	15 KVA/36 Amps	18 KVA/21 Amps	25 KVA/61 Amps	28 KVA/58 Amps	23 KVA/27 Amps	26 KVA/65 Amps
VOLTAGE REQUIRED	208-240 Volts/ 3 Phase	480 Volts/3 Phase	480 Volts/3 Phase	480 Volts/3 Phase	480 Volts/3 Phase	480 Volts/3 Phase	480 Volts/3 Phase

3-AXIS VERTICAL MACHINING CENTERS

40 TAPER | VM SERIES

The Milltronics VM Series vertical machining centers offer a great combination of features and performance at an attractive price. The VM Series machines are belt-driven and include standard features such as full enclosures, swing-arm tool changers, 10,000 RPM BIG-PLUS® dual contact spindles, the INSPIRE+ control, and more.



ONLINE PRICING AT
MILLTRONICS.COM/
GETPRICING

INCLUDED AT NO EXTRA COST

STANDARD FEATURES

- ✓ Heavily ribbed one piece fine grain cast iron casting
- ✓ Fully enclosed machine guard with side doors
- ✓ 30/35 mm linear way technology
- ✓ Precision ground ballscrews supported at both ends
- ✓ Precision ground table surface
- ✓ Telescopic metal way covers
- ✓ 24 pocket double arm ATC
- ✓ BIG-PLUS® ISO No. 40
- ✓ Automatic positive displacement lubrication system
- ✓ High torque AC digital servo drives
- ✓ High torque closed loop vector spindle drive system
- ✓ Dual work lights
- ✓ Spindle taper blow-out and tool release button
- ✓ Spare "M" function with CNC "wait" channel
- ✓ Programmable on/off flood coolant system
- ✓ Rigid tap
- ✓ Remote handwheel
- ✓ Chip auger chip removal system
- ✓ Air gun
- ✓ Coolant wash down gun
- ✓ Supervisory passcode
- ✓ Spindle load meter
- ✓ Feedrate and spindle speed overrides
- ✓ Spindle air purge
- ✓ End of cycle light
- ✓ One year warranty
- ✓ INSPIRE+ Control
- ✓ Auxiliary industrial grade keyboard

OPTIONS

- Through-spindle coolant system
- Part and tool probes
- 4th axis options
- 5th axis options
- Lift up chip conveyor chip removal system
- Electronic spindle chiller
- BT style tooling
- ChipBoss™ Trochoidal Milling Software
- Milltronics Shop View
- Digital Setup Assistant
- Programmable spray mist and air blast

Specifications subject to change without notice. Some machines shown with options.

SPECIFICATIONS	VM2515	VM3018	VM4020	VM5020	VM5020EZ
TABLE					
TABLE WORKING SURFACE	30 x 16 in (762 x 406 mm)	34 x 18 in (864 x 457 mm)	46 x 20 in (1,168 x 508 mm)	52 x 20 in (1,321 x 508 mm)	52 x 20 in (1,321 x 508 mm)
TABLE T-SLOTS	3 x .71 in (18 mm)	4 x .71 in (18 mm)	5 x .71 in (18 mm)	5 x .71 in (18 mm)	5 x .71 in (18 mm)
MAXIMUM WEIGHT ON TABLE	3,140 lbs (1,420 kg)	3,770 lbs (1,710 kg)	3,770 lbs (1,710 kg)	3,770 lbs (1,710 kg)	3,770 lbs (1,710 kg)
TRAVELS					
X-AXIS	25 in (635 mm)	30 in (762 mm)	40 in (1016 mm)	50 in (1270 mm)	50 in (1270 mm)
Y-AXIS	15 in (381 mm)	18 in (457 mm)	20 in (508 mm)	20 in (508 mm)	20 in (508 mm)
Z-AXIS	20 in (508 mm)	20 in (508 mm)	20 in (508 mm)	20 in (508 mm)	20 in (508 mm) WITH 150 MM RISER
SPINDLE MOTOR					
SPINDLE POWER (MAXIMUM)	15/10 HP (11/7.5 kW)	20/15 HP (15/11 kW)	20/15 HP (15/11 kW)	20/15 HP (15/11 kW)	20/15 HP (15/11 kW)
SPINDLE TORQUE (MAXIMUM)	54 ft-lbs (73 Nm)	75 ft-lbs (102 Nm)	75 ft-lbs (102 Nm)	75 ft-lbs (102 Nm)	75 ft-lbs (102 Nm)
SPINDLE					
SPINDLE TAPER	BIG-PLUS® ISO. No. 40	BIG-PLUS® ISO. No. 40	BIG-PLUS® ISO. No. 40	BIG-PLUS® ISO. No. 40	BIG-PLUS® ISO. No. 40
SPINDLE NOSE TO TABLE	4-24 in (101-610 mm)	4-24 in (101-610 mm)	4-24 in (101-610 mm)	4-24 in (101-610 mm)	9.9-29.9 in (251-759 mm)
SPINDLE SPEED (MAXIMUM)	10,000 RPM	10,000 RPM	10,000 RPM	10,000 RPM	10,000 RPM
TOOL CHANGER					
TOOL CAPACITY / TYPE	24 / DOUBLE ARM	24 / DOUBLE ARM	24 / DOUBLE ARM	24 / DOUBLE ARM	24 / DOUBLE ARM
TOOL SHANK	CAT 40	CAT 40	CAT 40	CAT 40	CAT 40
RETENTION KNOB	MAS 60	MAS 60	MAS 60	MAS 60	MAS 60
MAXIMUM TOOL DIAMETER	3.15 in (80 mm)	3.15 in (80 mm)	3.15 in (80 mm)	3.15 in (80 mm)	3.15 in (80 mm)
MAXIMUM TOOL LENGTH	9.45 in (240 mm)	9.45 in (240 mm)	9.45 in (240 mm)	9.45 in (240 mm)	9.45 in (240 mm)
MAXIMUM TOOL WEIGHT	15.4 lbs (7 kg)	15.4 lbs (7 kg)	15.4 lbs (7 kg)	15.4 lbs (7 kg)	15.4 lbs (7 kg)
FURTHER DETAILS					
X/Y/Z RAPID TRAVERSE RATE	945 IPM (24 m/min)	945 IPM (24 m/min)	945 IPM (24 m/min)	945 IPM (24 m/min)	945 IPM (24 m/min)
MACHINE HEIGHT	101.5 in (2,565 mm)	102 in (2,570 mm)	102 in (2,570 mm)	102 in (2,570 mm)	107.3 in (2,725 mm)
FOOTPRINT: MAXIMUM SERVICE SPACE - (WIDTH x DEPTH)	130 x 119 in (3,303 x 3,023 mm)	136.5 x 126.4 in (3,466 x 3,210 mm)	146.5 x 126.4 in (3,722 x 3,210 mm)	162 x 125 in (4,115 x 3,175 mm)	162 x 125 in (4,115 x 3,175 mm)
FOOTPRINT: NOMINAL OPERATING - (WIDTH x DEPTH)	96.5 x 101 in (2,450 x 2,553 mm)	117 x 110 in (2,972 x 2,777 mm)	117.6 x 103 in (2,988 x 2,615 mm)	130 x 111.7 in (3,303 x 2,836 mm)	130 x 111.7 in (3,303 x 2,836 mm)
MACHINE WEIGHT	6,834 lbs (3,100 kg)	9,000 lbs (4,100 kg)	9,436 lbs (4,280 kg)	9,833 lbs (4,730 kg)	9,833 lbs (4,730 kg)
POWER REQUIRED	18 KVA/25 Amps	25 KVA/29 Amps	25 KVA/29 Amps	25 KVA/29 Amps	25 KVA/29 Amps
VOLTAGE REQUIRED	480 Volts / 3 Phase	480 Volts / 3 Phase	480 Volts / 3 Phase	480 Volts / 3 Phase	480 Volts / 3 Phase

3-AXIS VERTICAL MACHINING CENTERS

40 TAPER INLINE | IL SERIES

The “IL” stands for “**inline spindle**”, since this series of vertical machining centers is equipped with a 40-taper BIG-PLUS® dual-contact inline spindle. Inline spindles run smooth and quiet with minimal heat and reduced vibration, providing better surface finish and longer tool life. The 12,000 RPM inline spindles have dual-wound spindle motors for faster acceleration/deceleration and more torque. The IL machines also have bigger castings, faster rapids, and more standard features.



ONLINE PRICING AT
MILLTRONICS.COM/
GETPRICING

INCLUDED AT NO EXTRA COST

STANDARD FEATURES

- ✓ Heavily ribbed one piece fine grain cast iron casting
- ✓ Fully enclosed machine guard with side doors
- ✓ 35/45 mm roller linear way technology
- ✓ Precision ground ballscrews supported at both ends
- ✓ Precision ground table surface
- ✓ Telescopic metal way covers
- ✓ 30 pocket arm type ATC
- ✓ BIG-PLUS® ISO No. 40
- ✓ Automatic positive displacement lubrication system
- ✓ High torque AC digital servo drives
- ✓ High torque closed loop vector spindle drive system
- ✓ Dual work lights
- ✓ Spindle taper blow-out and tool release button
- ✓ Single spare “M” function with CNC “wait” channel
- ✓ Programmable on/off flood coolant system
- ✓ Rigid tap
- ✓ Supervisory passcode
- ✓ Spindle load meter
- ✓ Feedrate and spindle speed overrides
- ✓ Spindle air purge
- ✓ End of cycle light
- ✓ Chip conveyor chip removal system
- ✓ Remote handwheel
- ✓ Air gun
- ✓ Coolant wash down gun
- ✓ One year warranty
- ✓ INSPIRE+ Control
- ✓ Auxiliary industrial grade keyboard

OPTIONS

- Through-spindle coolant system
- Part and tool probes
- 4th axis options
- 5th axis options
- Electronic spindle chiller
- BT style tooling
- 40 pocket ATC (available on the VM4224IL, VM5025IL, and VM6030IL)
- 15,000 RPM spindle
- Thermal head mapping
- ChipBoss™ Trochoidal Milling Software
- Milltronics Shop View
- Digital Setup Assistant
- Programmable spray mist and air blast

Specifications subject to change without notice. Some machines shown with options.

SPECIFICATIONS	VM3020IL	VM4224IL	VM5025IL	VM6030IL
TABLE				
TABLE WORKING SURFACE	34 x 18 in (864 x 457 mm)	50 x 24 in (1,270 x 610 mm)	54 x 25 in (1,372 x 635 mm)	66 x 30 in (1,680 x 762 mm)
TABLE T-SLOTS	4 x .71 in (18 mm)	5 x .71 in (18 mm)	6 x .71 in (18 mm)	.71 in (18 mm)
MAXIMUM WEIGHT ON TABLE	3,140 lbs (1,420 kg)	3,660 lbs (1,660 kg)	4,190 lbs (1,900 kg)	4,190 lbs (1,900 kg)
TRAVELS				
X-AXIS	30 in (762 mm)	42 in (1,067 mm)	50 in (1,270 mm)	60 in (1,524 mm)
Y-AXIS	20 in (508 mm)	24 in (610 mm)	25 in (635 mm)	30 in (762 mm)
Z-AXIS	22 in (560 mm)	24 in (610 mm)	24 in (610 mm)	24 in (610 mm)
SPINDLE MOTOR				
SPINDLE POWER (MAXIMUM)	32.2/10 HP (19/7.5 kW)	32.2/10 HP (19/7.5 kW)	35/20 HP (26/15 kW)	35/20 HP (26/15 kW)
SPINDLE TORQUE (MAXIMUM)	89.2 ft-lbs (121 Nm)	89.2 ft-lbs (121 Nm)	124 ft-lbs (168 Nm)	124 ft-lbs (168 Nm)
SPINDLE				
SPINDLE TAPER	BIG-PLUS® ISO. No. 40	BIG-PLUS® ISO. No. 40	BIG-PLUS® ISO. No. 40	BIG-PLUS® ISO. No. 40
SPINDLE NOSE TO TABLE	6-28 in (152-712 mm)	6-30 in (152-762 mm)	4-28 in (101.5-711.5 mm)	4-28 in (101.5-711.5 mm)
SPINDLE SPEED (MAXIMUM)	12,000 RPM (15,000 RPM optional)	12,000 RPM (15,000 RPM optional)	12,000 RPM (15,000 RPM optional)	12,000 RPM (15,000 RPM optional)
TOOL CHANGER				
TOOL CAPACITY / TYPE	30 / DOUBLE ARM	30 / DOUBLE ARM	30 / DOUBLE ARM	30 / DOUBLE ARM
TOOL SHANK	CAT 40	CAT 40	CAT 40	CAT 40
RETENTION KNOB	MAS 60	MAS 60	MAS 60	MAS 60
MAXIMUM TOOL DIAMETER	3.15 in (80 mm)	3.15 in (80 mm)	3.15 in (80 mm)	3.15 in (80 mm)
MAXIMUM TOOL LENGTH	11.8 in (300 mm)	11.8 in (300 mm)	11.8 in (300 mm)	11.8 in (300 mm)
MAXIMUM TOOL WEIGHT	15.4 lbs (7 kg)	15.4 lbs (7 kg)	15.4 lbs (7 kg)	15.4 lbs (7 kg)
FURTHER DETAILS				
X/Y/Z RAPID TRAVERSE RATE	1,200/1,000 IPM (30.5/25.4 m/min)	1,200/1,000 IPM (30/25 m/min)	1,000/787 IPM (25.4/20 m/min)	1,000/787 IPM (25.4/20 m/min)
MACHINE HEIGHT	119 in (3,025 mm)	121 in (3,060 mm)	122 in (3,100 mm)	126.4 in (3,210 mm)
FOOTPRINT: MAXIMUM SERVICE SPACE - (WIDTH x DEPTH)	161 x 146.8 in (4,089 x 3,729 mm)	179.8 x 133.8 in (4,566 x 3,399 mm)	198.9 x 165.6 in (5,052 x 4,207 mm)	220.6 x 152 in (5,602 x 3,864 mm)
FOOTPRINT: NOMINAL OPERATING - (WIDTH x DEPTH)	85.8 x 124.1 in (2,180 x 3,152 mm) 115.7 in (2,940 mm) with conveyor	110.2 x 133.8 in (2,798 x 3,399 mm) 138.1 in (3,508 mm) with conveyor	128 x 143 in (3,252 x 3,630 mm) 173.3 in (4,403 mm) with conveyor	149.8 x 149.4 in (3,804 x 3,794 mm) 184.4 in (4,685 mm) with conveyor
MACHINE WEIGHT	10,891 lbs (4,940 kg)	14,775 lbs (6,702 kg)	19,400 lbs (8,800 kg)	23,369 lbs (10,600 kg)
POWER REQUIRED	26 KVA/31 Amps	26 KVA/31 Amps	36 KVA/44 Amps	36 KVA/44 Amps
VOLTAGE REQUIRED	480 Volts/3 Phase	480 Volts/3 Phase	480 Volts/3 Phase	480 Volts/3 Phase

3-AXIS VERTICAL MACHINING CENTERS

50 TAPER | XP SERIES

The “XP” stands for “**extra power**” since these CNC machines are built with a 50 taper spindle and linear cross roller guides for rigidity, direct-coupled ballscrews for faster response, and dual-wound spindle motors for faster acceleration/deceleration and more torque. Standard with up to 35 HP for maximum metal removal, the XP Series features a heavy duty belt drive spindle and also includes more standard features, such as a coolant ring and washdown system, lift-up chip conveyor, and height adjustment on the control.



ONLINE PRICING AT
MILLTRONICS.COM/
GETPRICING

INCLUDED AT NO EXTRA COST

STANDARD FEATURES

- ✓ Heavily ribbed one piece fine grain cast iron casting
- ✓ Fully enclosed machine guard with side doors
- ✓ 45 mm roller linear way technology
- ✓ Precision ground ballscrews supported at both ends
- ✓ Precision ground table surface
- ✓ Telescopic metal way covers
- ✓ 30 pocket double arm ATC
- ✓ BIG-PLUS[®] ISO No. 50
- ✓ Automatic positive displacement lubrication system
- ✓ High torque AC digital servo drives
- ✓ High torque closed loop vector spindle drive system
- ✓ Dual work lights
- ✓ Spindle taper blow-out and tool release
- ✓ Spare “M” function with CNC “wait” channel
- ✓ Programmable on/off flood coolant system
- ✓ Rigid tap
- ✓ Supervisory passcode
- ✓ Spindle load meter
- ✓ Feedrate and spindle speed overrides
- ✓ Spindle air purge
- ✓ End of cycle light
- ✓ Chip conveyor and washdown chip removal system
- ✓ Remote handwheel
- ✓ Air gun
- ✓ Coolant wash down gun
- ✓ One year warranty
- ✓ INSPIRE+ Control
- ✓ Auxiliary industrial grade keyboard

OPTIONS

- Through-spindle coolant system
- Programmable spray mist coolant
- Tool and part probes
- 4th axis options
- 5th axis options
- Electronic spindle chiller
- BT style tooling
- ChipBoss™ Trochoidal Milling Software
- Milltronics Shop View
- Digital Setup Assistant

Specifications subject to change without notice. Some machines shown with options.

SPECIFICATIONS	VM5025XP	VM6030XP	VM8434XP
TABLE			
TABLE WORKING SURFACE	54 x 25 in (1,372 x 635 mm)	66 x 30 in (1,680 x 762 mm)	86 x 34 in (2,184 x 865 mm)
TABLE T-SLOTS	6 x .71 in (18 mm)	7 x .71 in (18 mm)	7 x .71 in (18 mm)
MAXIMUM WEIGHT ON TABLE	4,190 lbs (1,900 kg)	4,190 lbs (1,900 kg)	4,750 lbs (2,150 kg)
TRAVELS			
X-AXIS	50 in (1,270 mm)	60 in (1,524 mm)	84 in (2,134 mm)
Y-AXIS	25 in (635 mm)	30 in (762 mm)	34 in (864 mm)
Z-AXIS	24 in (610 mm)	24 in (610 mm)	30 in (762 mm)
SPINDLE MOTOR			
SPINDLE POWER (MAXIMUM)	35/25 HP (26/18 kW)	35/25 HP (26/18 kW)	35/25 HP (26/18 kW)
SPINDLE TORQUE (MAXIMUM)	208.5 ft-lbs (283 Nm)	208.5 ft-lbs (283 Nm)	208.5 ft-lbs (283 Nm)
SPINDLE			
SPINDLE TAPER	BIG-PLUS® ISO. No. 50	BIG-PLUS® ISO. No. 50	BIG-PLUS® ISO. No. 50
SPINDLE NOSE TO TABLE	6-30 in (152-762 mm)	4-28 in (101-710 mm)	5-35 in (127-889 mm)
SPINDLE SPEED (MAXIMUM)	8,000 RPM	8,000 RPM	8,000 RPM
TOOL CHANGER			
TOOL CAPACITY / TYPE	30 / DOUBLE ARM	30 / DOUBLE ARM	32 / DOUBLE ARM
TOOL SHANK	CAT 50	CAT 50	CAT 50
RETENTION KNOB	ANSI 5.50-1978	ANSI 5.50-1978	ANSI 5.50-1978
MAXIMUM TOOL DIAMETER	4.9 in (125 mm)	4.9 in (125 mm)	4.9 in (125 mm)
MAXIMUM TOOL LENGTH	11.8 in (300 mm)	11.8 in (300 mm)	11.8 in (300 mm)
MAXIMUM TOOL WEIGHT	33 lbs (15 kg)	33 lbs (15 kg)	33 lbs (15 kg)
FURTHER DETAILS			
X/Y/Z RAPID TRAVERSE RATE	1,000/787 IPM (25.4/20 m/min)	1,000/787 IPM (25.4/20 m/min)	709/530 IPM (18/13.5 m/min)
MACHINE HEIGHT	129 in (3,276.5 mm)	128 in (3,251 mm)	146.3 in (3,715 mm)
FOOTPRINT: MAXIMUM SERVICE SPACE - (WIDTH x DEPTH)	198.7 x 141 in (5,048 x 3,582 mm)	220.6 x 149.4 in (5,602 x 3,794 mm)	411.7 x 165.4 in (10,458 x 4,202 mm)
FOOTPRINT: NOMINAL OPERATING - (WIDTH x DEPTH)	128 x 142 in (3,250 x 3,608 mm) 173.5 in (4,405 mm) with conveyor	150 x 148.5 in (3,810 x 3,772 mm) 184.5 in (4,690 mm) with conveyor	203 x 162.5 in (5,160 x 4,125 mm) 226.7 in (5,760 mm) with conveyor
MACHINE WEIGHT	19,400 lbs (8,800 kg)	24,119 lbs (10,940 kg)	42,438 lbs (19,250 kg)
POWER REQUIRED	38 KVA/94 Amps	38 KVA/94 Amps	43 KVA/107 Amps
VOLTAGE REQUIRED	400-480 VAC	400-480 VAC	400-480 VAC

5-AXIS VERTICAL MACHINING CENTERS

5X SERIES

Milltronics **5-axis machining centers** feature a rotary table that offers $+30^{\circ}/-110^{\circ}$ of A-axis rotation and 360° in the C-axis. These vertical mills are equipped with a BIG-PLUS[®] spindle and the INSPIRE+ control, which provides improved surface finish and cycle times, an advanced proprietary motion engine, and a 19-inch, color, LCD touch screen. Built for rigidity, wide spacing of the linear roller guideways ensure optimal support for the table and saddle in full travel of each axis.



ONLINE PRICING AT
MILLTRONICS.COM/
GETPRICING

SPECIFICATIONS	VM200-5X	VM250IL-5X
TABLE		
TABLE WORKING SURFACE	7.8 in / 198 mm diameter	9.8 in / 248 mm diameter
TABLE T-SLOTS	6 x .39 (10 mm)	6 x .47 in (12 mm)
MAXIMUM WEIGHT ON TABLE	330 lbs (150 kg)	440 lbs (200 kg)
TRAVELS		
X-AXIS	21 in (534 mm)	30 in (762 mm)
Y-AXIS	16 in (407 mm)	20 in (508 mm)
Z-AXIS	19 in (483 mm)	20.5 in (520 mm)
C-AXIS	360°	360°
A-AXIS	+30°/-110°	+30°/-110°
SPINDLE MOTOR		
		INLINE
SPINDLE POWER	10/7.4 HP (7.5/5.5 kW)	32.2/10 HP (19/7.5 kW)
SPINDLE TORQUE	25.8 ft-lbs (35.0 Nm)	89.2 ft-lbs (121 Nm)
SPINDLE		
SPINDLE TAPER	BIG-PLUS® ISO. No. 40	BIG-PLUS® ISO No. 40
SPINDLE NOSE TO TABLE	1.97-20.98 in (50-533 mm)	3.5-24 in (90-610 mm)
SPINDLE SPEED (MAXIMUM)	10,000 RPM	15,000 RPM
TOOL CHANGER		
TOOL CAPACITY / TYPE	24 / DOUBLE ARM	40 / DOUBLE ARM
TOOL SHANK	CAT 40	CAT 40
RETENTION KNOB	MAS 60	MAS 60
MAXIMUM TOOL DIAMETER	3.1 in (80 mm)	3 in (76 mm)
MAXIMUM TOOL LENGTH	9.8 in (240 mm)	13.8 in (350 mm)
MAXIMUM TOOL WEIGHT	15.4 lbs (7 kg)	15.4 lbs (7 kg)
FURTHER DETAILS		
X/Y/Z RAPID TRAVERSE RATE	945 IPM (24 m/min)	1,200 / 1,200 / 1,000 IPM (30.5 / 30.5 / 25.4 m/min)
C-AXIS / A-AXIS ROTATIONAL SPEED	25 RPM	25 RPM
POSITIONING ACCURACY	+/- 0.0004 in (+/- 0.010 mm)	+/- 0.0004 in (+/- 0.010 mm)
REPEATABILITY	0.0002 in (0.005 mm)	0.0002 in (0.005 mm)
MACHINE HEIGHT	106 in (2,695 mm)	124.1 in (3,153 mm)
FOOTPRINT: NOMINAL OPERATING - (WIDTH x DEPTH)	130.1 x 115.6 in (3,304 x 2,937 mm)	150.2 x 145 in (3,816 x 3,684 mm)
MACHINE WEIGHT	7,738 lbs (3,510 kg)	13,068 lbs (5,940 kg)
POWER REQUIRED	18 KVA/25 Amps	26 KVA/31 Amps
VOLTAGE REQUIRED	480 Volts / 60 Hz	480 Volts / 60 Hz

INCLUDED AT NO EXTRA COST

STANDARD FEATURES

- ✓ INSPIRE+ control
- ✓ 19" color LCD touch screen display
- ✓ BIG-PLUS® dual-contact spindle
- ✓ Spindle load meter
- ✓ Spindle air purge
- ✓ Automatic positive displacement lubrication system
- ✓ Full enclosure with side doors
- ✓ Dual-enclosure work lights
- ✓ Rigid tapping
- ✓ Spare "M" function
- ✓ Solid model graphic display
- ✓ 120-GB solid state hard drive
- ✓ DXF file import
- ✓ Rest roughing machining cycle

OPTIONS (AVAILABILITY VARIES BY FRAME)

- ChipBoss™ Trochoidal Milling Software
- Milltronics Shop View (MSV) - Internet-Based Machine Monitoring
- Digital Setup Assistant (DSA)
- Thermal Head Mapping - Thermal Sensors in Head with Algorithms
- DGI-Desktop PC Software for Programming and Training
- 70-mm BIG-PLUS® Dual-Contact 15,000-RPM Spindle with Ceramic Bearings
- BT Style Tooling
- Programmable Air Blast
- Programmable Spray Mist System
- Through-Spindle Coolant System
- Spindle Chiller
- Electrical Cabinet Air Conditioning
- Lift-Up Chip Conveyor Upgrade Replaces Auger
- Factory machine installation and on-site training (USA only)

Specifications subject to change without notice. Some machines shown with options.

VERTICAL MACHINING CENTERS



ONLINE PRICING AT
MILLTRONICS.COM/
GETPRICING

TOOL ROOM LATHES

TRL SERIES

The TRL Series is Milltronics' newest line of tool room lathes. They can be run manually or in full CNC mode, offering the versatility to accommodate different skillsets and jobs. With solid box way construction for added rigidity, TRL Series lathes deliver robust turning and milling capabilities, designed for high-performance machining in a compact form.



ONLINE PRICING AT
MILLTRONICS.COM/
GETPRICING

INCLUDED AT NO EXTRA COST

STANDARD FEATURES

- ✓ Solid box way construction
- ✓ Gap bed design
- ✓ Tailstock
- ✓ Auto lubrication
- ✓ Flood coolant
- ✓ Full enclosure with sliding door
- ✓ Milltronics 9000-DGI CNC control
- ✓ 15" LCD color touch screen display
- ✓ USB ports
- ✓ Spindle load meter
- ✓ Part wire frame & solid model graphics
- ✓ Constant surface speed (CSS)
- ✓ Thread chasing cycle
- ✓ One-year warranty

OPTIONS (AVAILABILITY VARIES BY FRAME)

- Bi-directional turning cycle
- Hydraulic 3-jaw chuck
- Programmable hydraulic quill only tailstock
- Steady rest
- 5C air operated collet closer w/ footswitch
- Spindle brake
- Belt-type chip conveyor with washdown

Specifications subject to change without notice. Some machines shown with options.

SPECIFICATIONS	TRL16/60	TRL18/60	TRL22/60	TRL26/80	TRL26/80HD
CAPACITY					
X/Z TRAVELS	11/66.5 in (280/1,690 mm)	11.81/66.5 in (300/1,690 mm)	11.81/66.53 in (300/1,690 mm)	18.1/84.65 in (460/2,150 mm)	18.1/84.65 in (460/2,150 mm)
SWING OVER BED	16.7 in (425 mm)	18.7 in (475 mm)	24.4 in (620 mm)	28.74 in (730 mm)	28.74 in (730 mm)
SWING OVER GAP	25.98 in (660 mm)	27.95 in (710 mm)	30.3 in (770 mm)	34.25 in (870 mm)	34.25 in (870 mm)
GAP DISTANCE	12.6 in (320 mm)	12.6 in (320 mm)	12.6 in (320 mm)	12.6 in (320 mm)	12.6 in (320 mm)
SWING OVER CROSS SLIDE	7.48 in (190 mm)	9.45 in (240 mm)	11.8 in (300 mm)	16.1 in (410 mm)	16.1 in (410 mm)
SPINDLE					
SPINDLE NOSE	A2-5	A2-6	A2-8	A2-8	A2-15
SPINDLE BORE	2.04 in (52 mm)	2.56 in (65 mm)	4.13 in (105 mm)	4.13 in (105 mm)	7.28 in (185 mm)
SPINDLE RANGE	0-4,000 RPM	0-2,600 RPM	0-2,500 RPM	0-2,500 RPM	0-1,000 RPM
AC SPINDLE MOTOR	14.75/10 HP (11/7.5 kW)	20/14.75 HP (15/11 kW)	14.75/10 HP (11/7.5 kW)	14.75/10 HP (11/7.5 kW)	14.75/10 HP (11/7.5 kW)
SPINDLE TORQUE	72.4 ft-lbs (98.2 Nm)	160 ft-lbs (217 Nm)	620 ft-lbs (840 Nm)	620 ft-lbs (840 Nm)	775 ft-lbs (1,050 Nm)
TAILSTOCK					
TAILSTOCK QUILL TRAVEL	5.9 in (150 mm)	5.9 in (150 mm)	5.9 in (150 mm)	5.9 in (150 mm)	5.9 in (150 mm)
TAILSTOCK QUILL DIAMETER	3.15 in (80 mm)	3.15 in (80 mm)	3.94 in (100 mm)	3.94 in (100 mm)	3.94 in (100 mm)
TAILSTOCK QUILL TAPER	MT5	MT5	MT5	MT5	MT5
AUTOMATIC TURRET					
TOOL CAPACITY	8	8	8	8	8
TOOLING SIZE	.75 in (19 mm)	.75 in (19 mm)	1 in (25.4 mm)	1 in (25 mm)	1 in (25 mm)
BORING BAR CAPACITY	1.25 in (32 mm)	1.25 in (32 mm)	1.5 in (38 mm)	1.5 in (38 mm)	1.5 in (38 mm)
TOOL SELECTION	BI-DIRECTIONAL	BI-DIRECTIONAL	BI-DIRECTIONAL	BI-DIRECTIONAL	BI-DIRECTIONAL
FURTHER DETAILS					
X/Z RAPID TRAVERSE RATE	500 IPM (12.7 m/min)	500 IPM (12.7 m/min)	500 IPM (12.7 m/min)	500 IPM (12.7 m/min)	500 IPM (12.7 m/min)
POSITIONING ACCURACY	+/- 0.0004 in (+/- 0.010 mm)	+/- 0.0004 in (+/- 0.010 mm)	+/- 0.0004 in (+/- 0.010 mm)	+/- 0.0004 in (+/- 0.010 mm)	+/- 0.0004 in (+/- 0.010 mm)
REPEATABILITY	0.0002 in (0.005 mm)	0.0002 in (0.005 mm)	0.0002 in (0.005 mm)	0.0002 in (0.005 mm)	0.0002 in (0.005 mm)
AXIS THRUST FORCE X/Z	3,506.9 ft-lbs (15.6 kN) / 3,125 ft-lbs (13.9 kN)	3,506.9 ft-lbs (15.6 kN) / 3,125 ft-lbs (13.9 kN)	3,921 ft-lbs (17.4 kN) / 4,061 ft-lbs (18.1 kN)	3,921 lbs (17.4 kN) / 4,061 lbs (18.1 kN)	3,921 lbs (17.4 kN) / 4,061 lbs (18.1 kN)
MACHINE HEIGHT	93.6 in (2,378 mm)	93.6 in (2,378 mm)	94 in (2,388 mm)	94 in (2,388 mm)	94 in (2,388 mm)
FOOTPRINT: NOMINAL OPERATING - (WIDTH x DEPTH)	185.8 x 103 in. (4,719 x 2,616 mm)	185.8 x 103 in. (4,719 x 2,616 mm)	204.4 x 115.8 in (5,192 x 2,941 mm)	224 x 116.5 in (5,692 x 2,959 mm)	224 x 116.5 in (5,692 x 2,959 mm)
MACHINE WEIGHT	7,540 lbs (3,420 kg)	7,540 lbs (3,420 kg)	11,640 lbs (5,280 kg)	11,750 lbs (5,330 kg)	12,260 lbs (5,560 kg)
POWER REQUIRED	16 KVA/42 Amps	22 KVA/54 Amps	18 KVA/45 Amps	18 KVA/45 Amps	18 KVA/45 Amps
VOLTAGE REQUIRED	200-240 VAC / 60 Hz	200-240 VAC / 60 Hz	200-240 VAC / 60 Hz	230 VAC / 60 Hz	230 VAC / 60 Hz

SLANT BED LATHES

SL SERIES

The Milltronics SL Series CNC lathes offer a great combination of features and performance at an attractive price. They are well built, reliable, and easy to use.

The SL Series machines feature robust true slant bed castings, linear motion guide roller ways, direct-coupled ballscrews, and the 9000 Series control.

SPECIFICATIONS	SL6II	SL8II	SL10II
CAPACITY			
X-AXIS TRAVEL	7 in (176 mm)	8 in (203 mm)	9.8 in (250 mm)
Z-AXIS TRAVEL	14 in (356 mm)	21 in (533 mm)	31.1 in (790 mm)
SWING OVER BED DIAMETER	15.9 in (405 mm)	21.7 in (525 mm)	22.9 in (582 mm)
SWING OVER CROSS SLIDE DIAMETER	9.45 in (240 mm)	11.8 in (300 mm)	15.8 in (402 mm)
MAXIMUM TURNING DIAMETER	12.4 in (316 mm)	14 in (356 mm)	17.7 in (450 mm)
MAXIMUM TURNING LENGTH	13.4 in (340 mm)	20.67 in (525 mm)	29.8 in (758 mm)
SPINDLE			
SPINDLE NOSE	A2-5	A2-6	A2-8
DRAW TUBE DIAMETER	1.77 in (45 mm)	2.54 in (64.5 mm)	3.18 in (81 mm)
SPINDLE BORE DIAMETER	2.2 in (56 mm)	3.1 in (78 mm)	3.74 in (95 mm)
CHUCK SIZE	6 in (152 mm)	8 in (203 mm)	10 in (254 mm)
SPINDLE RANGE	0-6,000 RPM	0-4,000 RPM	0-3,000 RPM
AC SPINDLE MOTOR	17/10 HP (13/7.5 kW)	30/20 HP (23.2/15 kW)	29.5/20 HP (22/15 kW)
MAXIMUM SPINDLE TORQUE	83 ft-lbs (113 Nm) @ 1,090 RPM	161 ft-lbs (219 Nm) @ 1,000 RPM	260 ft-lbs (352 Nm) @ 600 RPM
TURRET			
TOOL CAPACITY	12	12	12
TOOL SIZE	.75 x .75 in (19 x 19 mm)	1 x 1 in (25 x 25 mm)	1 x 1 in (25 x 25 mm)
BORING BAR CAPACITY	1.25 in (32 mm)	1.5 in (40 mm)	1.5 in (40 mm)
TOOL SELECTION	BI-DIRECTIONAL	BI-DIRECTIONAL	BI-DIRECTIONAL
TAILSTOCK OPTION			
TAILSTOCK QUILL TRAVEL	3.46 in (88 mm)	3.46 in (88 mm)	4.7 in (119 mm)
TAILSTOCK QUILL DIAMETER	2.28 in (58 mm)	2.28 in (58 mm)	3.54 in (90 mm)
TAILSTOCK THRUST	550 lbs (250 kg)	550 lbs (250 kg)	550 lbs (250 kg)
TAILSTOCK QUILL TAPER	MT4	MT4	MT5
MOTION			
MAXIMUM CUTTING FEED RATE	1,181 IPM (30 m/m)	1,181 IPM (30 m/m)	1,181 IPM (30 m/m)
POSITIONING ACCURACY	+/- 0.0002 in (+/- 0.005 mm)	+/- 0.0002 in (+/- 0.005 mm)	+/- 0.0002 in (+/- 0.005 mm)
REPEATABILITY	0.0002 in (0.005 mm)	0.0002 in (0.005 mm)	0.0002 in (0.005 mm)
AXIS THRUST FORCE X/Z	1,851 lbs (8.2 kN)	1,951 lbs (8.2 kN)	3,125 lbs (13.9 kN)

SPECIFICATIONS	SL6II	SL8II	SL10II
FURTHER DETAILS			
X/Z RAPID TRAVERSE RATE	1,181 IPM (30 m/min)	1,181 IPM (30 m/min)	1,181 IPM (30 m/min)
MACHINE HEIGHT	86.3 in (2,193 mm)	86.3 in (2,193 mm)	88.5 in (2,248 mm)
FOOTPRINT: MAXIMUM SERVICE SPACE - (WIDTH x DEPTH)	169.1 x 104.4 in (4,486 x 2,651 mm)	169.1 x 104.4 in (4,486 x 2,651 mm)	191.4 x 112.4 in (4,860 x 2,854 mm)
FOOTPRINT: NOMINAL OPERATING - (WIDTH x DEPTH)	125.2 x 98.6 in (3,180 x 2,504 mm)	142.8 x 88.3 in (3,628 x 2,244 mm)	163.9 x 94.8 in (4,163 x 2,408 mm)
MACHINE WEIGHT	7,050 lbs (3,200 kg)	8,885 lbs (4,030 kg)	10,670 lbs (4,840 kg)
POWER REQUIRED	16 KVA/39 Amps	26 KVA/64 Amps	24 KVA/59 Amps
VOLTAGE REQUIRED	208-240 Volts/ 3 Phase	208-240 Volts/ 3 Phase	208-240 Volts/ 3 Phase



INCLUDED AT NO EXTRA COST

STANDARD FEATURES

- ✓ 3-jaw hydraulic chuck with foot switch
- ✓ 12 position auto turret with 1" slots
- ✓ True slant bed with one-piece base casting
- ✓ Linear motion guide ways with roller type bearings
- ✓ Full enclosure with sliding door
- ✓ Hydraulic tailstock
- ✓ Chip conveyor
- ✓ Flood coolant
- ✓ Auto lubrication
- ✓ Part, wire frame, and solid model graphics
- ✓ Constant Surface Speed (CSS)
- ✓ Spindle load meter
- ✓ One year warranty
- ✓ 9000 Series Control

OPTIONS

- Parts catcher
- Mist collector
- Bar feed interface
- Bi-directional turning cycle
- Automatic tool setter
- Additional spare "M" functions
- Oil skimmer
- Collet chucks
- Digital Setup Assistant
- Milltronics Shop View

Specifications subject to change without notice. Some machines shown with options.

SLANT BED LATHES



ONLINE PRICING AT
MILLTRONICS.COM/
GETPRICING

CONVERSATIONAL & USER-FRIENDLY CONTROL

The **INSPIRE+ with INSPIRE software** gives your machinists a more powerful tool for complex milling. Benefits include conversational programming features that improve surface finish and cycle times, an advanced proprietary motion engine, and an open architecture for future machine technologies. With new Industry 4.0 and IoT tech support, the INSPIRE fulfills every software need you'll ever face.

OVERVIEW

Intuitive

With its conversational programming, on-screen help, intuitive menus, color graphics, and prompted tool settings, the Milltronics control helps new operators get up to speed quickly.

Productive

The Milltronics control allows operators to run parts programmed conversationally or toolpaths generated by a CAM system. Coupled with a super-fast motion control system, feature packed CNC, and interface designed to expedite setup and operation, the Milltronics control is the solution to helping your operator make parts faster and better.

Efficient

The Milltronics control is packed with features that foster quick and confident operation, such as solid model graphics that allow the operator to see a completed part prior to cutting. The mid-program restart function allows the operator to start anywhere in a program by verifying the graphics - no need for G&M code expertise! . A dual-core processor and high-speed motion control executes 3,000 blocks per second.



HIGHLIGHTS

ChipBoss™

ChipBoss™ uses proprietary algorithms to calculate toolpaths and control the maximum allowable cutter engagement, resulting in:

- Faster cycle times - reduced by as much as 50% or more.
- Better tool life - extends life by 3-5 times.
- More accurate parts via reduction in tool deflection

ChipBoss™ uses trochoidal milling strategies with deeper depths of cut and smaller stepovers:

- Feed rates can be much higher than what conversational users are used to experiencing.
- Reduces the number of times a machine needs to accelerate and decelerate – less wear and tear
- Includes Rest Roughing – automatically calculates the areas to be machined and uses a smaller cutter to get just those areas that can't be cut with larger tool, saving even more time.

NEW! MotionBoss™ (Optional)

This patented control technology enables you to maximize cutting efficiency by managing the balance between speed and precision.

Using a racecar analogy, MotionBoss™ allows you to set the width of the track along with the maximum speed. The INSPIRE control then determines the optimal path around the track, automatically accelerating between line segments or slowing down for a tight turn, providing you with a faster cutting time, less chatter, less vibration, and less machine jerk.

Remote Support (TeamViewer)

Our latest software empowers users to remotely access their machine from anywhere to view diagnostics and real-time monitoring. INSPIRE v11 also supports MTConnect and has remote support, with interactive troubleshooting, remote PC access, and augmented reality to help fix the issue and get back to making parts.

Improved Ergonomic Design

While INSPIRE+ provides a familiar user experience for those who know Milltronics' previous control (9000-DGI), it also introduces upgraded ergonomics and a refined user interface. Highlights include faster processing, enhanced graphics, a larger 19-inch touchscreen, and support for mouse and keyboard attachments.

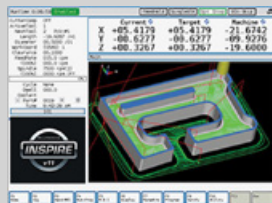

ChipBoss™



NEW! MotionBoss™



Remote Support (TeamViewer)

CONTROL FEATURES

- Optional Four and Five Axis Simultaneous
- 3,000 Blocks / Second High Speed Processor
- Absolute / Incremental
- 120 GB Solid State Hard Drive
- 4 GB Ram Memory
- 500 MB Text Editing with Cut, Copy, Move, Search and Replace
- Ball Screw Pitch Error Correction
- True S Curve Acceleration and Jerk Correction
- Feed Forward Error Correction
- Full Language Error Messages
- Backlash Compensation
- Linear, Circular, Helical and Interpolation
- Feed Per Rev, Minute, Inverse Time
- Custom I/O Screens
- Surface Finish Selection (SFS)
- Aux Keyboard Port
- Networking
- Calculator
- Service Diagnostics
- Parts Counter
- Supervisory Passcode

- Remote Diagnostics
- Rigid Tapping
- Selectable Corner Accuracy
- Selectable Languages
- Handwheel Scroll through Menus
- Automatic Homing
- Two USB Ports
- Hour Meter

Programming Features

- Concurrent Programming
- Cutter Compensation
- Inch / Metric
- Mirror, Scale and Rotate
- Dwell
- Subprogram Call, Loops, Grid, Spaced
- Tapered and Round Walls
- Engraving with Serializing
- Cartesian and Polar Coordinates
- Corner Chamfering and Rounding
- Tool Change Recovery Feature
- Single Page Auto-Routines
- Bolt Pattern, Drill, Tap and Bore Cycles
- Text Engraving on Arc or Line
- Thread Milling Cycle
- Circular Framing Cycle
- Rectangular Framing Cycle
- Polygon Framing Cycle
- Circular Pocket Cycle
- Rectangular Pocket Cycle
- Polygon Pocket Cycle
- Slot Cycle
- Facing Cycle
- Canned Cycles
- Milling Cycles
- Drill, Tap and Bore Cycles
- Custom Drill Cycle
- Rotary Axis Cylindrical Mapping
- 3D Sweep Routine
- Irregular Pocket Clear with Islands
- Conversational Programming
- DXF File Import
- Math Function Input Fields
- Macro Variable Programming
- Custom Conversational Screens
- Speed and Feed Calculator
- Prompting Help Screens

G&M Code Programming

- Macro Programming
- MDI
- EIA / ISO Code (Fanuc®) Compatibility

Trig Help Features

- Arc and Line Intersection Find
- Tangent Line and Arc Functions
- 3 Point Arc Generation
- Line Extend Back

Run and Verify Features

- Handwheel Run
- Dry Run
- Block Skip, Optional Stop, Programmable Stop and Single Block
- Multiple Mid Program Start Options such as Modal /Non-Modal
- Mill Away / Jog Away
- Program Halt and Resume
- Tool Load Monitoring
- Tool Breakage Detection with Optional Tool Setter

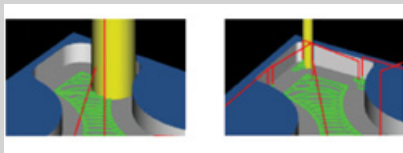

Rest Roughing



PC & Hardware Upgrades



Remote Support (TeamViewer)

CONTROL FEATURES

- Estimated Cycle Time
- Variable Rapid Override Select
- Spindle Load Meter
- Fine Tune Feed and Spindle Override
- Machine Status Light
- Programmable Air, Mist and Coolant

Set Up Features

- Automatic Tool Setting Program
- Single Button Tool / Fixture Offset Entry
- 60 Work Coordinates
- Continuous and Incremental Axis Jog
- Electronic Handwheel(s)
- Optional Probe and Tool Setter
- 199 Tool Diameter Length and Wear Offsets
- DRO Measure
- Safe Zone
- Hot Keys

Edit Features

- Background Editing
- Cut, Copy, Paste and Move Editing, Within and Outside of the Current Program
- Handwheel through Text (Characters, Lines, Pages) while Editing Programs
- Overwrite and Insert
- Global Find and Replace
- Printout a Program (Fastcam)

Display Features

- 3D Part and Wire Frame Tool Path Graphics
- Color Graphics — Tool Path and Part Profile
- Solid Model Graphics
- Wireframe over Solids
- Transparent Graphics
- Customizable DRO
- User Definable Image Display Window
- User Selectable Graphics in all Planes

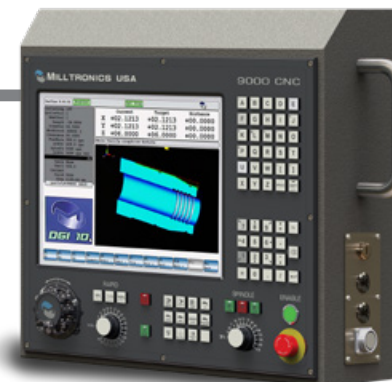

9000 SERIES CONTROL

At Milltronics, our controls simplify operation, shorten setup times, and provide features that reduce cycle times. Our lathes come with the 9000 control, which features 120 GB disk storage, 4 GB memory, mid-travel tactile keys, and a 15-inch LCD touch screen. It's a Windows®-based platform and offers all the user-friendly features that Milltronics CNC controls are known for, such as the G-code visualization screen.

Standard on TRL + SL Series.

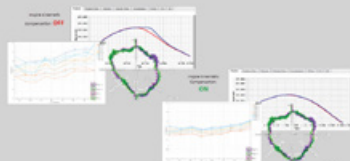

Kinematic Compensation Suite

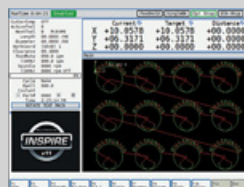

Canned Cycles



Bi-Directional Turning

SUPERIOR DESIGN & QUALITY COMPONENTS

Milltronics partners with world-class suppliers for critical components used in the design and manufacture of our CNC machines.

SLANT BED FRAME



Rigid true slant bed casting, direct coupled ballscrews, with roller style linear guides.

VERTICAL MILL FRAME



Oversized and widely spaced linear cross roller ways for rigidity and accuracy—provide 40% more rigidity than standard ball ways

- Milltronics uses a design process that is ISO 9001 certified to make rigid and reliable machines built to last.
- Heavily ribbed and supported fine grain cast iron optimized with Finite Element Analysis (FEA) provides superior dampening characteristics and added rigidity for heavy machining applications.
- Machines are designed with rapid traverse rates and high feeds to minimize cycle times and increase productivity.
- Variety of efficiency enhancing options such as thermal head mapping, linear glass scales, through-spindle-coolant, spindle chillers, rotary tables, bar feeders, and automation solutions are available.



BIG-PLUS® SPINDLES

Milltronics mills* are equipped with the BIG-PLUS® spindle system that improves rigidity with simultaneous fit of taper and face, which provides better heavy or high speed cutting, better deep or large diameter boring, and longer tool life.

*Not available on VK4II, TRQ20 models

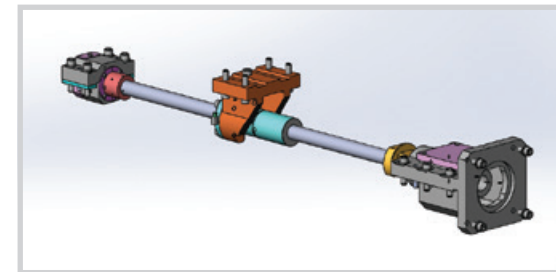

Direct coupled ballscrews.

BALLSCREWS

The VM/VM-IL/VM-XP Series of machines feature direct coupled Hiwin® premium grade double-nut pre-loaded ballscrews, anchored at both ends as well as Hiwin® linear motion guides. The double-nut ballscrews apply pressure in opposite directions to the ballscrew which keeps the nut under tension and prevents backlash. The ballscrews are also pre-tensioned, providing greater rigidity and help to negate the effects of thermal growth.



SERVOS AND DRIVES

Milltronics uses state-of-the-art premium servos and drives from some of the world's largest manufacturers including Yaskawa, Mitsubishi, and Delta. All of these motors and drives feature:

- Exceptional velocity loop frequency response time
- Digital encoders
- Enhanced vibration suppression
- Faster speed acceleration and deceleration
- Worldwide service and parts support

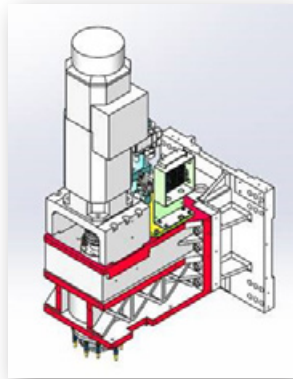

VM-IL SPINDLE TRANSMISSION

Belts are eliminated with spindle and motor directly inline. This delivers higher performance in acceleration, reduced vibration for better part finish, and quieter operation.

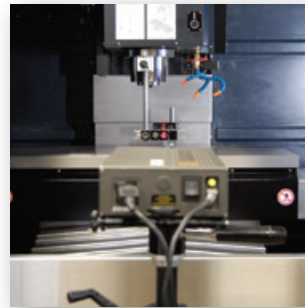

LASER INTERFEROMETER

After assembly, Milltronics machines are tested, including the use of a laser interferometer. The laser interferometer provides comprehensive accuracy assessment of machine alignment and any roll-pitch-yaw errors in machine.

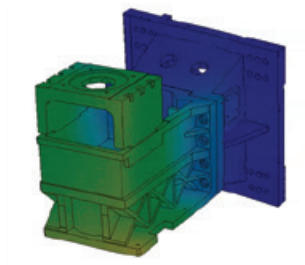

FINITE ELEMENT ANALYSIS

Finite Element Analysis (FEA) is used to evaluate structural rigidity, torsional stiffness, thermal characteristics and natural frequency to achieve the best frame design. This is critical with today's high velocities and accelerations – machine performance must be carefully optimized in order to maintain part quality.

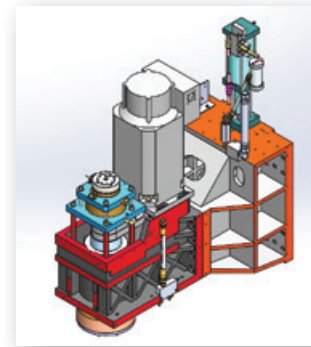

VM-XP SPINDLE

For extra cutting power, the heavy-duty belt-driven spindles on the VM-XP machines are equipped with a dual wound spindle motor.



ITX TECHNOLOGY

The modular design of the ITX rack provides highly reliable CNC operation as it uses fewer parts and features reduced connections. The CPU module uses less power and runs cooler for dependable operation.



SWING ARM ATC

Milltronics uses electric swing arm automatic tool changers on the VM/IL/XP Series. All arm movements are driven from a single cam ensuring reliable and smooth movements that never need adjustment.



CHIP MANAGEMENT

Milltronics machines are available with numerous coolant and chip removal options. Depending on model, through-spindle coolant, air through the spindle, programmable air blast and spray mist are available. Chip removal options include chip augers, chip conveyors and coolant washdown.

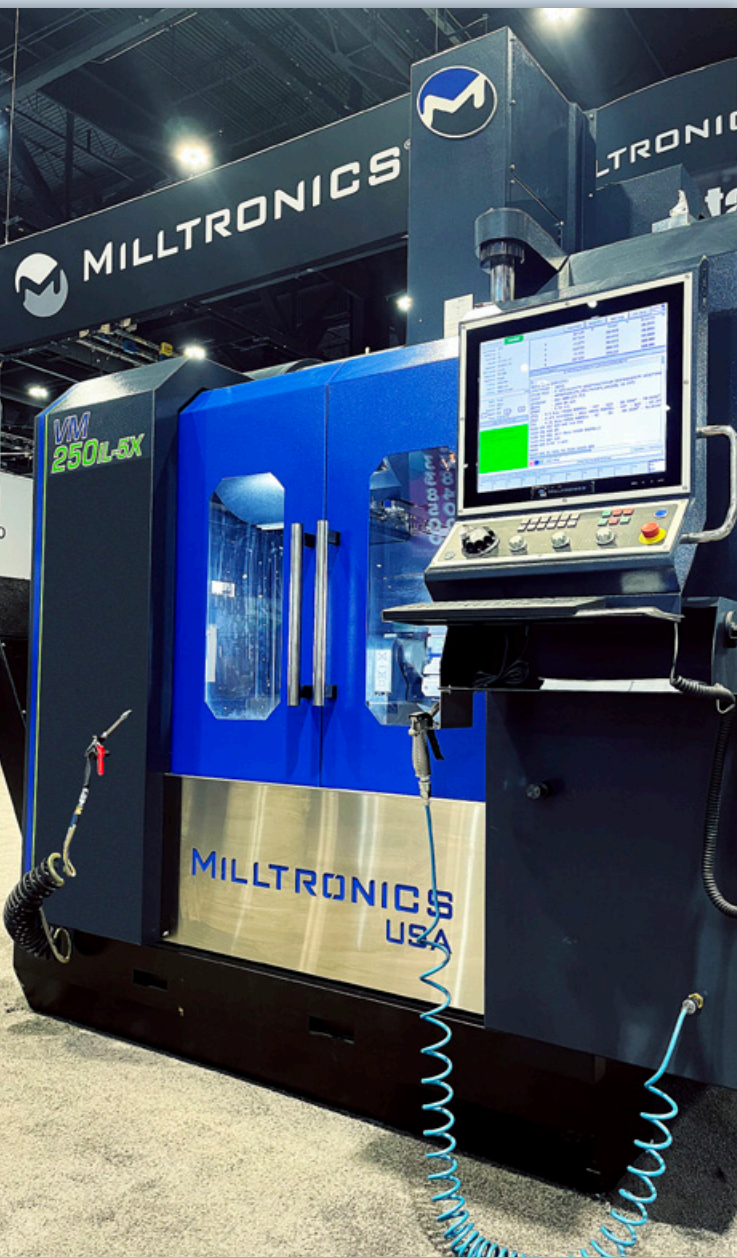

NEW RESOURCES FOR MACHINISTS MILLTRONICS' MACHINE SHOP INSIGHTS



At Milltronics, we're committed to more than just building machines — we're here to support machinists, shop owners, and manufacturers in their pursuit of precision, productivity, and growth. That's why we're excited to introduce "Milltronics' Machine Shop Insights," **our brand-new blog** designed to be your go-to resource for information on topics ranging from running your machines to running your business.

WHAT YOU CAN EXPECT

"Milltronics' Machine Shop Insights" will deliver practical, actionable content each month to help you get the most out of your Milltronics equipment and optimize your shop's performance. Here's what you can look forward to:

- **Tips & Techniques:** Quick, effective strategies to improve machining accuracy, reduce setup time, and streamline workflows.
- **How-To Guides:** Step-by-step instructions covering everything from programming with Milltronics controls to routine machine maintenance.
- **Troubleshooting Tricks:** Solutions to common CNC issues, helping you minimize downtime and keep your machines running smoothly.
- **Customer Stories:** Real-world examples showcasing how shops like yours are using Milltronics machines to overcome challenges and achieve success.
- **Business Strategies:** Information and opinions on industry trends and best practices from Milltronics subject matter experts.
- **Product Spotlights:** In-depth looks at Milltronics machines, features, and updates that can make a difference in your daily operations.

WHY SUBSCRIBE?

By subscribing to "Milltronics' Machine Shop Insights," you'll receive fresh content delivered straight to your inbox every month. Stay ahead of the curve with the **latest tips, tricks, and industry insights** that can help you tackle challenges, improve efficiency, and grow your business.

HOW TO SUBSCRIBE



Scan the QR code
now to subscribe
or visit
MILLTRONICS.com/blog



2920 FORTUNE CIRCLE WEST, SUITE C, INDIANAPOLIS IN 46241
888.999.1440 • MILLTRONICS.COM

Specifications subject to change without notice. Optimum machine performance is dependent upon installation conditions at the facility. Some machines shown with options.

Copyright © 2025 Milltronics USA, Inc. All rights reserved. Rev. D 08/25 C007-D